

## **7. SELECTION OF WATANA GENERAL ARRANGEMENT**

The proposed Susitna-Watana Project incorporates a concrete dam structure and a surface powerhouse, at a slightly different location than was originally planned in the 1980s. At that time, the Watana Project consisted of an earth core dam, together with an underground power plant, requiring a significant volume of fill materials for the dam (32.1 million cubic yards for Stage I Watana) and crushed rock for concrete aggregate. Accordingly, the construction materials would have been excavated from upland areas adjacent to the dam and at downstream locations (which would have been flooded by the reservoir formed by the proposed Devils Canyon Dam). The current proposed project, including the change in the dam type, a more compact general arrangement and the need for a large volume of construction aggregates has required additional investigations and engineering to determine technical feasibility.

### **7.1. Site Topography**

The Susitna River Basin is bordered by the Alaska Range to the north, the Chulitna and Talkeetna Mountains to the west and south and the northern Talkeetna plateau and Gulkana uplands to the east. This area is largely within the Coastal Trough province of south-central Alaska, a belt of lowlands extending the length of the Pacific Mountain system and interrupted by the Talkeetna, Clearwater, and Wrangell mountains.

The Susitna Basin has distinct and diverse combinations of landforms and waterforms. The deep V-shaped canyon of the middle Susitna River and tributary valleys, the Talkeetna Mountains, and the upland plateau to the east are the dominant topographic forms. Elevations in the basin range from approximately 700 ft. to more than 9,000 ft. Distinctive landforms include tundra highlands, active and post-glacial valleys, and numerous lakes.

In the vicinity of the proposed Watana Dam site (project river mile 187), the Susitna River has incised a narrow, steep-walled, east-west valley up to 800-ft. deep into the broad Fog Lakes upland formed by repeated glaciations and surrounded by mountains of 3,000–6,300 ft. in elevation. The Susitna River at the dam site is relatively wide and turbulent. On the right bank (north) the valley rises at about a 2H:1V slope from river level at El. 1450 ft., for approximately 600 ft., then flattens to a maximum elevation of 2,350 ft. Conversely, the left bank (south) rises more steeply from the river for about 450 ft. at a slope of 1.4H:1V, then flattens to 3H:1V or less to approximately El. 2600 ft.

## **7.2. Environmental Considerations**

Project environmental studies are being conducted under 55 Federal Energy Regulatory Commission (FERC) approved study plans (plus three engineering studies) authorized and managed by AEA. The environmental studies are being performed by separate contractors administered by AEA. The results of those studies will be used to prepare a licensing proposal and license application that will form the foundation of discussions culminating in the formulation of project mitigation and enhancement measures and to prepare environmental monitoring plans and programs.

While the costs associated with potential project environmental monitoring and mitigation cannot be estimated accurately until the environmental studies are complete and discussions with licensing participants have ensued, an initial overall estimate has been made by AEA in order to have some basic funding considered in the full cost estimates for the Project. This initial overall environmental mitigation cost estimate is included in the total project cost estimate as described in Section 13.

With respect to feasibility analysis, the following environmental considerations have been taken into account in the proposed design, and/or in the Opinion of Probable Construction Cost (OPCC):

- Environmental mitigation during construction operations including but not limited to:
  - Sedimentation and erosion control;
  - Revegetation and landscaping at the end of construction;
  - Stormwater pollution prevention;
  - Invasive species monitoring and control; and,
  - Avian protection plans including potential scheduling to avoid cutting and clearance during bird migratory periods. The Avian Protection Plan would also include transmission line designs that assist with raptor protection.
- The inclusion of as much flexibility as possible in the design and configuration of the various hydraulic components so that the following options are viable:
  - Releases during reservoir filling (impounding) to maintain river flow and water quality, as well as maintain downstream ice conditions and boating use initially through the emergency release system (which will have a varying capacity up to 30,000 cubic feet per second [cfs] at minimum reservoir elevation 1,850 ft.), and then through the low level outlets;

- Discharges of flows during operation up to the 50 year flood through the low level outlets – to avoid using the spillway – benefiting the downstream fishery;
  - Facilities to vary the depth at which water is drawn into the turbines to enhance downstream water temperatures as desired; and,
  - Discharges during operation to maintain river flow, maintain desired downstream ice conditions or boating depths, or to provide flushing (pulse) flow through the low-level outlet.
- Orientation of permanent lighting (on the dam and around the permanent village) to minimize disruption of migratory birds.

No provisions have been made at this point for wildlife protection measures as those are not yet known until the studies and agency consultation process is complete. Similarly, the feasibility study does not address any potential anadromous fish passage past the completed dam. This aspect of the development is being investigated as one of the 58 ongoing studies that include technical workshops with resource agencies with expertise in fish passage considerations. Aspects being considered in that study includes “trap and haul”, a ladder, a fish lift, and fish movement via Tsusena Creek. No cost has been included in the OPCC to reflect any infrastructure for fish passage.

A benefit of the operational modeling – that has been performed (and described in Section 12) using the PROMOD software package – has been a detailed assessment of the Railbelt carbon dioxide (CO<sub>2</sub>) emissions resulting from electrical power generation. The Railbelt system was modeled – using economic dispatch – in 2024 (around the time the project is expected to be operational), and 2034 (ten years after the start of operation), and indicates the following emission per megawatt hour (MWh) with and without the Susitna-Watana Project as shown below in Table 7.2-1:

**Table 7.2-1. Railbelt Electrical Power Generation Carbon Dioxide Emissions (tons x 1000)**

	Railbelt
Year 2024	
Without Watana	2893.52
With Watana	1665.03
Reduction	1228.49
Year 2034	
Without Watana	2777.65
With Watana	1395.69
Reduction	1381.96

Reductions in CO<sub>2</sub> emissions also result from the proposed transmission upgrades that are being considered separately from the Susitna-Watana Project.

### **7.3. Selection of Reservoir Levels**

A brief review of the history of proposed reservoir levels at the Watana Dam site is an appropriate starting point for the current selection of the Watana Dam maximum normal operating level (NMOL). The proposed Stage I Watana Dam from the 1985 Susitna Hydroelectric Project FERC License Application (APA 1985) was a 700-foot-high dam with a reservoir NMOL at El. 2000 ft. The Stage I Watana Dam was planned to exist by itself for six years. The 1985 Stage II plan included construction of a downstream Devils Canyon Dam. The 1985 Stage III plan, which represented the ultimate project development, would have raised Watana Dam by 185 ft. so that the NMOL was at El. 2185 ft. The Stage III Watana Dam was scheduled to be completed seven years following completion of Stage II. This clearly indicates that the El. 2000 ft. Watana Reservoir was not envisioned in 1985 as the appropriate long-term Watana NMOL.

The Railbelt Large Hydro Evaluation Preliminary Decision Document (AEA 2010) identified a 700-foot-high dam at Watana as the preferred project. In this document, Susitna-Watana was selected as the preferred alternative from among two major projects (the Chakachamna Hydro Project was the other alternative) but the document did not attempt to evaluate alternative sizes of Watana Dam. In the Pre-Application Document (PAD), Watana Dam was described as having a nominal crest level at El. 2025 ft. Watana Dam is currently planned to be a standalone project and there are no current plans to stage the height of the dam. This brief history of Watana Dam plans indicated that further evaluation of the maximum normal reservoir level for Watana Dam is appropriate.

The primary benefit of Watana Dam is the generation of hydroelectric energy. In the Alaska Railbelt region, electricity demand is substantially greater during the cold season months of November through April than during the remainder of the year, which means that energy from the Susitna-Watana Project is most needed during the November through April season. However, the reservoir inflows at the Watana Dam site are out of phase with the energy demand. The reservoir inflows for the six months from May through October (5,300,000 acre-ft. average inflow) are on average about ten times greater than the reservoir inflows for the six months of November through April (510,000 acre-ft. average inflow).

Providing substantial active reservoir storage is the means by which the natural reservoir inflows can be reshaped and released in a seasonal pattern that closely follows the electricity demand. Active storage is the volume of water that will normally be stored or withdrawn for power operations and minimum flow releases. Active storage is the reservoir storage in acre-feet

between the NMOL and the minimum operating level (MOL). Water stored below the MOL is termed “dead storage.”

For the previously conceived (AEA, PAD 2011 and Preliminary Decision Document 2010) Watana Dam with El. 2000 ft. maximum normal pool, there would be 2,310,000 acre-ft. of active (live) storage between the MOL at El. 1850 ft. and the NMOL at El. 2000 ft. The gross Watana Reservoir storage capacity is about 4,100,000 acre-ft. up to El. 2000 ft. With an average annual inflow to the reservoir of about 5,800,000 acre-ft. (8,015 cfs), the active storage volume is about 40 percent of the average annual inflow volume. This amount of active storage provides the potential to shift at most 44 percent of the May through October inflows to the November through April cold season when Watana power generation is most needed.

Subsequent feasibility study work conducted during the period from 2011 through 2013 led to consideration of incorporating more reservoir storage into project plans to optimize power production for the maximum benefit of the Railbelt utilities. Raising the NMOL to El. 2050 ft., while still maintaining the minimum operating level at El. 1850 ft. , increases the active storage to 3,380,000 acre-ft. This active storage would represent 58 percent of the average annual inflow volume and 64 percent of the average May through October inflow volume. The El. 2050 ft. NMOL would result in an increase of about 31 percent in the energy generation from November through April in comparison to the El. 2000 ft. maximum normal pool studied previously. An El. 2050 ft. Watana reservoir offers the potential to shape outflows so that they are much more similar to the seasonal pattern of Railbelt electricity demand. It is also noted for comparison purposes that the Watana Stage III reservoir (ultimate development) as proposed in 1985 had a similar reservoir active storage of 3,700,000 acre-ft. between El. 2065 ft. (MOL) and El. 2185 ft. (NMOL).

Although increasing the reliable energy generation during the November through April high electricity demand season by increasing active storage is the primary reason for setting the - Watana Dam NMOL at El. 2050 ft., there are several other supporting factors including the following:

- Increased active storage also increases the reliability of releases for other purposes, such as minimum instream flow releases, flushing flows, or other environmental releases.
- Increased active storage reduces non-power releases (spill) at the dam, and the attendant loss of energy benefits.
- A raised Watana Dam slightly increases the average head on the turbines resulting in a slight increase in generation.

- There is a relict channel between the right reservoir bank and Tsusena Creek. Seepage that could occur through coarse-grained material in the relict channel is a function of hydraulic gradient and distance. For Watana Dam NMOL above about El. 2050 ft., remedial treatment of the relict channel could become a substantial cost factor.
- The mouth of the Oshetna River would not be inundated with the NMOL at El. 2050 ft.
- The El. 2050 ft. NMOL would place the Watana Dam height within existing industry experience for constructed roller-compacted concrete (RCC) dams.
- Greater active storage reduces downstream flooding.

Considering the substantially increased benefits of setting the NMOL at El. 2050 ft., it was selected as the maximum normal operating level for the reservoir.

## **7.4. Selection of the Inflow Design Flood**

The Inflow Design Flood (IDF) is used in the design of the spillways and other structures that are affected by maximum flood water levels. The adequacy of a spillway is evaluated by considering the hazard potential as well as the economic and environmental consequences that would result from hypothetical failure of the project works during passage of very large flood flows. For dams of different sizes and hazard potentials, the IDF may range anywhere from the 100-year flood up to the Probable Maximum Flood (PMF). Because of its size, downstream hazard potential, and economic importance to the Railbelt, the selected IDF for Watana Dam will be the PMF.

The PMF is the flood that may be expected from the most severe combination of critical meteorological and hydrologic conditions that are reasonably possible in the drainage basin under study. The PMF is generated by the probable maximum precipitation (PMP), which is defined as theoretically the greatest amount of precipitation for a given duration that is physically possible for a given size storm area at a particular geographic location at a certain time of year.

PMPs are often derived using publications like HMR 57 for the Pacific Northwest. However, there is no applicable guidelines for the Alaska region due to the large basin area, and it was therefore decided to prepare a site specific PMP. The determination of the PMP and the PMF are described in detail in Section 9 of this report.

## **7.5. Selection of Installed Capacity**

### **7.5.1. Introduction**

The selection of optimized installed capacity and generating unit size is a function of the expected performance in (and of) the Railbelt system, which will be most clearly defined as and

when there are agreed upon operating rules, payment provisions and protocols established between the participating utilities in a centrally dispatched system. When these parameters are defined, the required peak capacities of the Susitna-Watana generating units can be finally determined, prior to the start of detailed design.

Although it is possible to install a wide range of installed capacities at a hydroelectric powerhouse, installed capacities tend to fall within established ranges depending on the type of reservoir and operating mode associated with the project. In addition to the average annual energy, the generation attainable during winter months is of particular importance. It is established experience worldwide however that any hydro plant in a system tends to be relied upon over time more than the original expectations, because of its inherent flexibility. Many projects have added (and are adding) more generating capacity because the incremental cost of capacity at most hydroelectric power facilities is relatively low, dynamic benefits are recognized and becoming increasingly more valuable over time, and the flexibility of load following and peak shaving is of increasing value to the integrated system.

The initial selection of an installed capacity of 600 megawatts (MW) was made in the “Susitna Hydroelectric Project, Conceptual Alternative Design Report, 2009” by HDR and reaffirmed in the “Railbelt Large Hydro Evaluation – Preliminary Decision Document, November 2010” – also by HDR. The proposal, at that time, included four units each rated at 150 MW at a net head of 540 ft. A reduction in efficiency of 2 percent was assumed for every 100 ft. of head so the total capacity of the four units at MOL was suggested as 436 MW, and at normal maximum operating level as 608 MW. Normal maximum operation level of the pool was quoted as El. 2014 ft., and MOL as El. 1850 ft. The 98 percent firm winter capacity of the project was calculated to be 245 MW.

Clearly, any capacity above that immediately usable in the system at the time of project commissioning might be regarded as “overinvestment”. However projected load growth through 2024 and beyond is currently estimated to be extremely low – at an average of between 0.15 percent and 1 percent per annum, depending on the projection and which ten year period is being considered (as reported in the 2010 RIRP and other estimates prepared for this study by the utilities). It is prudent to consider that if – because of some unrecognized economic or societal phenomenon – load growth has been underestimated by just one percent for about five years out of the next ten or twenty years, the system peak load at 2024, 2034, and 2044 could well be higher by 100 MW or more. It is notable that even the difference in the various load growth projections examined from 2010 and 2012 was more than 100 MW. Therefore, it is prudent to allow for some flexibility in setting the project installed capacity at the feasibility stage.

## **7.5.2. Future Railbelt Electrical System Reliability / Redundancy Requirements**

### *7.5.2.1. Hydro Unit Reliability*

Hydro units are very reliable. According to performance statistics gathered by the North American Electricity Reliability Corporation (NERC), the average forced outage rate (percent time of unit downtime due to forced outage) for hydro units from 2007 to 2011 is 2.72 percent for units over 30 MW and of an average service life of more than 52 years. The average number of times each unit suffers a forced outage during this period is two per year. It should be noted that the statistics do not necessarily refer to unit trips alone. Importantly it should be remembered that the reliability of new units and larger units is better than older and smaller units – and NERC statistics include unit sizes down to 30 MW and an average age of more than 50 years.

The corresponding NERC reliability average forced outage rates for coal units up to 100 MW and for gas units of the same size are 6.99 percent and 5.81 percent, respectively, more than double the outage rate for hydro units. In addition, no gas or coal unit can be expected to reach the average age of the hydro units sampled, and the maximum life is likely to be of the order of 25 to 30 years for coal and significantly less for gas turbines.

Though a trip of a heavily loaded large unit at Watana Dam would be a significant event in the Railbelt system – and is discussed in Section 11 of this report – experience demonstrates that such a forced outage is significantly less probable for a hydro unit compared to thermal units on the system.

### *7.5.2.2. System Location of Spinning Reserve*

As discussed in Section 11 there is a concern by utilities at the spinning reserve requirements for what will be the largest units in the system at Watana Dam. The worst-case scenario would be for a fully loaded unit – operating at normal maximum operating level – to trip, and the restriction of load shedding to the current condition of Stage I load shedding is discussed in Section 11.

The time for various units on the system to ramp up and replace a Susitna-Watana unit is critical to the sizing of any mitigation of load shedding, and the following figures shown in Table 7.5-1 below are typical and achievable responses and ramp rates of units – drawn from industry experience and the specific units on the Railbelt System.



**Table 7.5-1. Typical Generating Unit Ramping Rates**

Unit type	Ramp Rate MW/minute or sec
Gas Turbine-spinning	5 MW per minute
Diesel – spinning	2 MW per minute
Steam Turbine – spinning (Coal)	3 MW per minute
Large Hydro – spinning	7 to 12 MW per second
Large Hydro – full load from standstill	180 seconds
Large Hydro – spinning in air to full power	120 seconds

The expected potential ramp rate of 7 to 12 MW per second (dependent on the water column acceleration) for the Susitna-Watana hydro units can be increased with some expense, and rates as high as 20 MW per second have been achieved in various plants. If the option to spin in air were included as a criterion for the project, then fast acting spherical valves would have to be incorporated into the powerhouse configuration.

It is reasonable that extra capacity above the basic capacity required for servicing the system demands could usefully be incorporated at Susitna-Watana, particularly as units loaded at 60 percent of full capacity will be the fastest and (operationally) the cheapest spinning reserve on the system. Such an arrangement would minimize the size of any mitigation such as a battery energy storage system (BESS) that might be instituted around the system. Assuming that some frequency droop will be tolerated (without other system units tripping), and using a ramp rate of 10 MW per second, a fast discharge battery bank or ultracapacitor (if development progress is satisfactory in the next 10 years) of 180 MW capacity and a storage of 1.5 to 2 MWh would seem appropriate for the units proposed. Conceivably a flywheel bank of similar performance would be acceptable to limit load shedding in the rare event of a unit trip at full load.

The BESS (or capacitors or flywheels) in the system would also be required if smaller units were installed at the Susitna-Watana Project, and is discussed in Section 11.

### **7.5.3. Selection of Powerhouse Total Installed Capacity**

#### **7.5.3.1. Selection Criteria**

The following items potentially have an influence on the selection of the powerhouse total installed capacity at Susitna-Watana:

- Maximizing total generation and the use of the available water – with the corresponding minimizing of spill;

- The extent to which the plant would be expected perform load following, peaking or peak shaving – governed by the rules of discharge agreed with other river stakeholders;
- The capability to meet assigned generation loads with a high reliability;
- A plant factor within a normal range for hydroelectric facilities;
- The extent to which other Railbelt thermal generating resources can increase generation during portions of dry year sequences when Watana Reservoir is at unusually low levels;
- The extent to which the project will “hold” spinning reserve for the system, whether by under loading units or by running a unit as a synchronous condenser (in air);
- The extent of “redundancy” in generating capacity selected for the project;
- The potential need for emergency operation of the project;
- The importance of seasonal generation requirements compared to reservoir levels; and,
- Any potential provision to be made for operating flexibility for future load growth whether by the capacity of the initial units installed, their capacity to be operated at a higher head if the reservoir were ever to be raised, and or the provision for installation of further units.

### 7.5.3.2. *Project Energy*

#### 7.5.3.2.1. *Long-Term Average Generation Simulation*

Early in the project feasibility studies, it was established that increasing the installed capacity above 600 MW to as high as 1,000 MW would not provide appreciable average annual energy benefits or increases in the November through April firm generation. However, increases in installed capacity above 600 MW could potentially be justified based on some other criterion. More recent power studies have included revised operating scenarios (load following alternatives), a higher normal maximum operating level for the reservoir, and inclusion of a dry year rule curve and preliminary inflow forecasting which allows generation to be maximized. To determine if these factors had a significant effect on the relationship of installed capacity to average annual generation, the power study runs described below were performed.

The average annual energy was calculated on an hourly basis for a 61-year period of reservoir historical inflow record for the Intermediate Load Following scenario. Intermediate Load Following assumes that the existing Bradley Lake, Eklutna Lake, and Cooper Lake hydroelectric plants would operate in a peaking mode to reduce the amount of load following that would be necessary at Susitna-Watana. No load following was assumed to occur at the gas-fired generation plants. Emergency load variations are excluded.

Two different installed capacities were used to verify the energy generation – three 200 MW units rated at normal maximum operating level for a total output of 600 MW, and three 200 MW units rated at average operating level (assumed to El. 1950 ft.) that are capable of about 785 MW at the normal maximum operating level.

The generation values presented herein represents generator output without deductions for outages and assumes that all potential generation is usable in the integrated system to meet load. Calculated average annual energy in GWh, without the added benefit of inflow forecasting is presented in Table 7.5-2.

**Table 7.5-2. Annual Generation for Alternative Installed Capacities, without Inflow Forecasting**

Installed Capacity	Intermediate Load Following (GWh)
3 x 200 MW @ operating level 1950	2,814
3 x 200 MW @ normal maximum operating level *	2,745
Difference in annual generation	2.5%

\* Equivalent to approx. 150 MW@ operating level 1950 ft.

The calculated energy noted above assumes no inflow forecasting (based on, for example snowpack data). The use of forecasting would better shape the monthly generation to the monthly load pattern, while reducing spill if smaller units are used. Because forecasting potentially may affect the selection of the installed capacity, model runs similar to those presented above were also performed to include preliminary forecasting. Forecasting is discussed in more detail in Section 12. Calculated average annual energy (GWh) for the cases that include preliminary inflow forecasting is shown in the following Table 7.5-3:

**Table 7.5-3. Annual Generation for Alternative Installed Capacities, with Inflow Forecasting**

Installed Capacity	Intermediate Load Following (GWh)
3 x 200 MW @ operating level 1950	2,802
3 x 200 MW @ normal maximum operating level *	2,780
Difference in annual generation	0.8%

\* Equivalent to approx. 150 MW@ operating level 1950 ft.

These results confirm that the larger units would not provide appreciable incremental average annual energy benefits. It is noted that the results show inflow forecasting slightly increasing the average annual generation for the 3 x 200 MW @ normal maximum operating level installed capacity, but slightly decreasing the average annual generation for the 3 x 200 MW @ average

operating level installed capacity. The increased generation with the smaller units occurs because water that otherwise would have spilled is used for generation in earlier months through forecasting. The decreased generation with the larger units occurs because water that is used for potential generation as the reservoir reaches the full pool level at El. 2050 ft. in the late summer becomes generation in the spring when the reservoir level is lower. At lower reservoir levels, each unit of water generates less energy than it would at higher reservoir levels. This transfer of generation from late summer to spring is justified because it better shapes generation to the electricity demand pattern of the Railbelt.

#### *7.5.3.2.2. PROMOD Average Water Condition Generation Simulation*

The Railbelt electric system, including all anticipated 2024 loads and individual generating resources, was simulated for one year of average water conditions using a production costing model called PROMOD. The year 2024 was assumed in the modeling to be the initial year of project operation. PROMOD model runs have been performed on the whole system assuming that the identified weak links in the Railbelt transmission system have been addressed, and centralized dispatch is undertaken so as to maximize system economic benefits. PROMOD, which is discussed in more detail in Section 5 and Section 12, performs economic dispatch of the generating resources on an hourly basis that results in integration of the Susitna-Watana generation into the Railbelt system. Susitna-Watana generation results for the Intermediate Load Following case are shown on Figure 7.5-1. The maximum hourly required generation in year 2024 was calculated to be 494.7 MW in November. A generation duration curve is shown on Figure 7.5-2, which corresponds to the year of hourly generation shown on Figure 7.5-1.

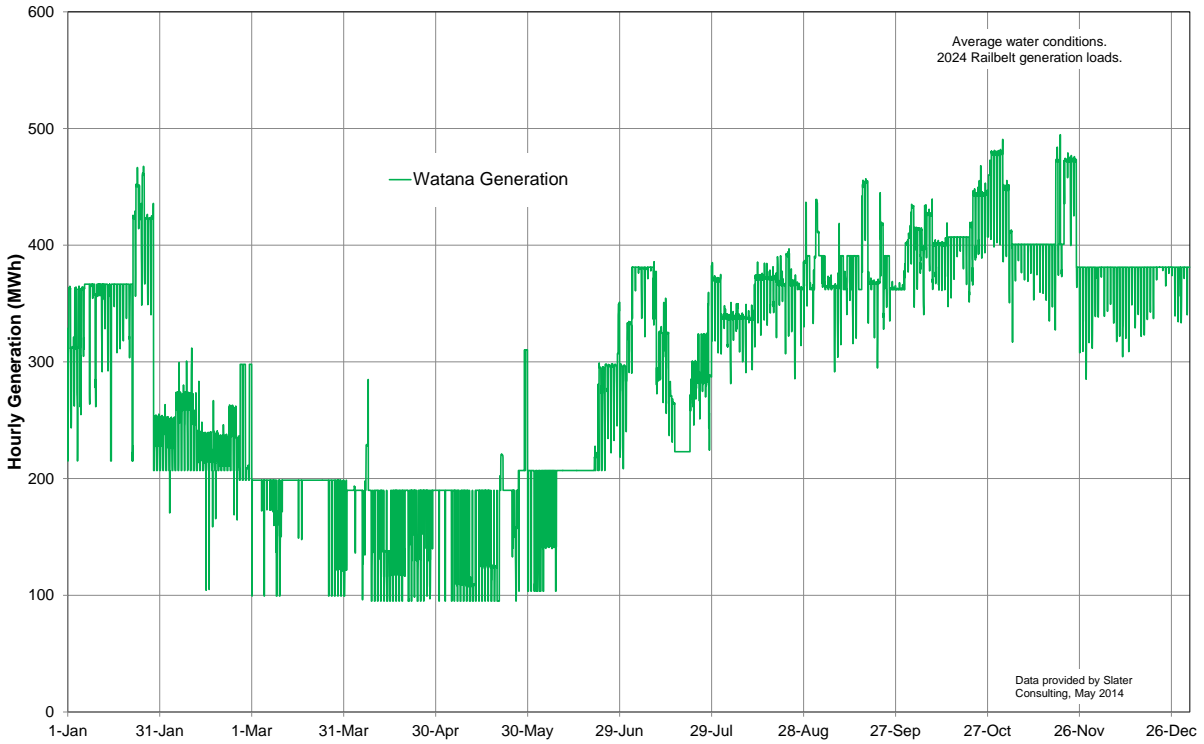

**Figure 7.5-1. Susitna-Watana Hourly Generation from PROMOD**

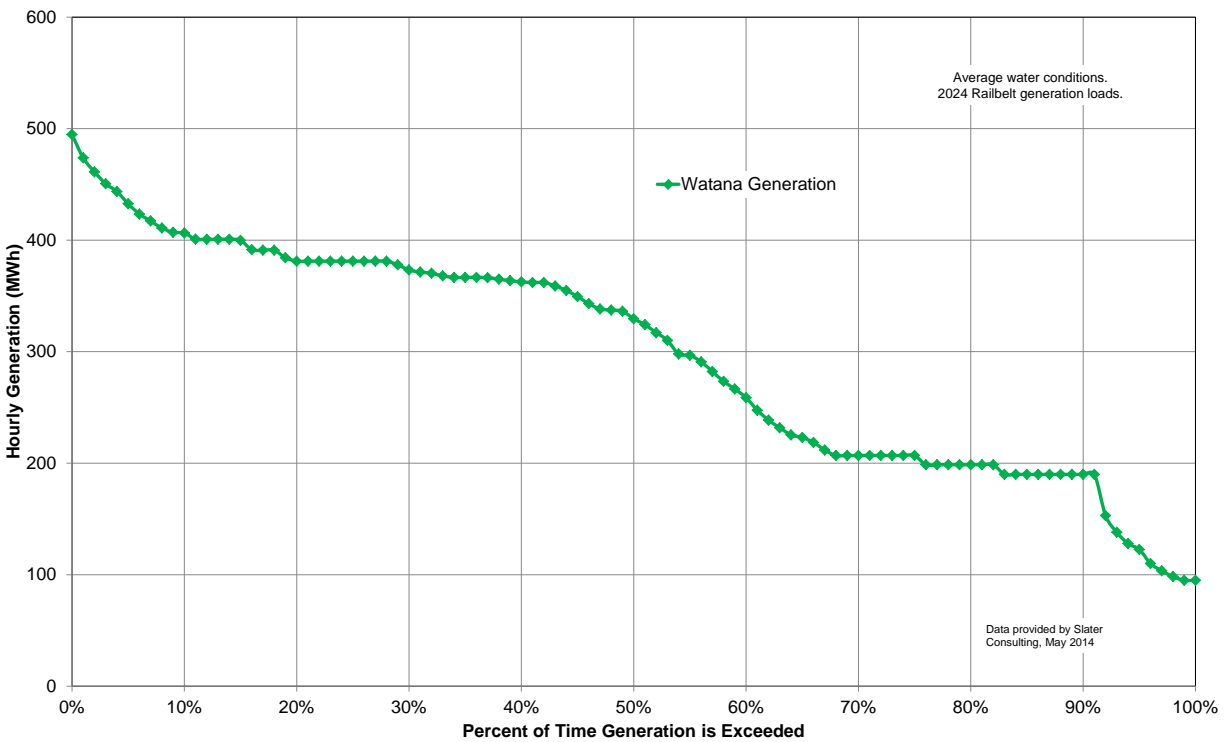

**Figure 7.5-2. Susitna-Watana Hourly Generation Duration Based on PROMOD Results**

A larger installed capacity has greater capacity at all reservoir operating levels compared to a smaller installed capacity that is rated at the same level. For the case of an installed capacity of 600 MW at the maximum normal operating level (equivalent to approximately 450 MW at reservoir level 1950 ft.), Table 7.5-4 shows the maximum monthly hour of generation from the PROMOD simulation, the Watana Reservoir elevation required to generate the maximum hour load, and the percent of time over 61 years that the reservoir level is high enough to generate the required maximum hourly load for the month. The results indicate that the installed capacity of 600 MW at the maximum normal operating level can generate to meet the required loads with very high reliability. Thermal generation would occasionally be increased when the Watana reservoir levels were unusually low and the generation requirements were high.

**Table 7.5-4. Reliability of Plant Capability for Maximum Hourly Generation**

Month	Watana Required Max. Hr (MW)	Required Watana Elev. (feet)	% of Time Required Elev. Is Exceeded
Jan	467.6	1967.4	88%
Feb	311.8	1857.3	100%
Mar	297.9	1850.0	100%
Apr	284.9	1850.0	100%
May	310.4	1856.2	97%
Jun	351.2	1886.5	96%
Jul	385.9	1911.4	100%
Aug	436.8	1946.8	100%
Sep	456.9	1960.3	100%
Oct	490.7	1982.6	98%
Nov	494.7	1985.2	94%
Dec	381.2	1908.0	100%
Average	389.2	1913.7	98%

#### 7.5.3.2.3. Energy Results Summary

The above project energy information leads to the following conclusions regarding installed capacity:

- The amount of assumed load following at Susitna-Watana has an insignificant effect on average annual generation for alternative installed capacities.
- The inclusion of inflow forecasting reduces the increase of annual potential generation of the larger installed capacity over the smaller installed capacity from about 2.5 percent to 0.8 percent.

- The powerhouse with an installed capacity of 600 MW at normal maximum operating level (equivalent to 450 MW at a reservoir elevation of 1950 ft.) is capable of meeting required generation loads with high reliability.
- Based on modeled energy generation results, there does not appear to be any compelling reason to increase the installed capacity above 600 MW at the normal maximum operating level.

As discussed in the following pages, a value of 600 MW was selected as the installed capacity for the Susitna-Watana powerhouse at maximum normal operating level (equivalent to 450 MW at a reservoir elevation of 1950 ft.).

### 7.5.3.3. Plant Factor

A reference value for installed capacity is also the plant factor. Plant factor is the ratio (may be expressed as a percent) of the average plant generation compared to the generation that would result if the plant generated continuously at the aggregate rating of all of the units. Run-of-river plants, which have no active storage, frequently have plant factors in roughly the 30–40 percent range. A hydroelectric peaking plant that has no minimum release requirements can have a plant factor of 25 percent or less. Hydroelectric plants that operate in purely a base load mode can have plant factors of 60 percent or higher. Hydroelectric plants that have substantial minimum release and base load requirements, but also work in a load-following mode (a combined operating mode), tend to have plant factors in the 40–60 percent range. The Susitna-Watana Project would be placed in the latter category – with a plant factor of approximately 53 percent, which falls into the normal range for a storage reservoir with a combined operating mode.

## 7.5.4. Generating Unit Selection and Capacity

### 7.5.4.1. Governing Criteria

*The units described in the PAD were 3 x 200 MW at average net head. This feasibility study has modified that proposal based on power studies and optimization, but maintaining the average annual generation. Studies have examined 100 MW units, 150 MW units and 200 MW rated at a reservoir El. 1950 ft., as well as 200 MW units rated at reservoir El. 2050 ft. (which are similar to 150 MW units rated at El 1950 ft.), before making an optimum selection. The project installed turbine capacity has been selected as 459 MW at a reservoir El. 1950 ft., equivalent to 446 MW generator output. Electrical system studies were performed on the unit selection in the PAD, and 150 MW units.*

The following have an influence on the selection of unit size at Susitna-Watana:

- The system response to a single unit trip at the project;
- The chosen operating regime at the project;
- The reliability of large hydro units compared to other thermal units within the system;
- The cost comparison between various unit sizes (capital cost dominates as operating costs are incrementally different though in favor of fewer units);
- The extent of “redundancy” in unit capacity selected for the project; and,
- The provision to be made for future load growth whether by the capacity of the initial units installed, their capacity to be operated at a higher head if the reservoir were ever to be raised, and/or the provision for installation of a further unit.

Additional factors to be considered include:

- The location of the Susitna-Watana Project halfway between two of the two main loads, Anchorage and Fairbanks;
- The possibility that the units can operate as synchronous condensers in air, which can also provide transmission stability benefits;
- The marginal cost of hydro capacity once the dam and associated costs are amortized;
- The convenience of having all units at a project the same size – even future units;
- The speed at which hydro units can be loaded compared to thermal units – particularly those at the proposed project with very short water column lengths; and,
- FERC License guidelines allow for an increase or decrease in the installed capacity of  $\pm 15$  percent before a “Capacity Amendment” is triggered, so a modicum of flexibility is available if the proposed installed capacity were to change before construction commences.

#### 7.5.4.2. Unit Rating

For the Susitna-Watana site, the selected turbine will be a vertical Francis reaction turbine, which is appropriate for the expected range of heads and flows and it can be expected to perform well over these conditions. However, for the purposes of project analysis and feasibility level design a rating must be chosen – which usually takes into account the operational regime of the plant. At this stage for the verification of feasibility, but without a full “Owners Requirements” based on agreement on the operation of the whole Railbelt system, assumptions have been made. As discussed below, the selected rating of the turbine units is 153 MW at reservoir level El. 1950 ft.,



for a total installed powerhouse turbine capacity of 459 MW – equivalent to 446 MW generator output. There is also provision for adding a future, fourth unit.

Based on the revised tailwater rating curve and a single unit operating, the range of net head on the units during operation (assuming a conservative three percent losses) can vary between approximately 383 ft. (at minimum operating level) and 577 ft. (at maximum normal operating level). The project is also being designed so that it is technically feasible for a future generation to raise the dam to accommodate a normal maximum operating water level of up to El. 2185 ft., which corresponds to a maximum net head on the units of 708 ft.

Using the USBR rule of thumb for the power head range for acceptable performance of a Francis turbine (from 65 percent to 125 percent of the rated head), and based on this envelope of required performance without other agreed constraints, it is common to set the rating of the unit (i.e., the head at which the turbine demonstrates peak efficiency) at the average net head of 480 ft. which facilitates satisfactory operation over the full anticipated range of reservoir operation (i.e., between minimum reservoir El. 1850 ft. and maximum reservoir El. 2050 ft.). Upon further modeling – during detailed design – based on the anticipated actual operation of the centrally dispatched system, it is possible that a turbine rating at a different head corresponding to the best overall efficiency (highest generation) might be considered. This elevation is liable to be somewhat higher than average reservoir elevation used for rating thus far.

For sizing of the water passages, flows and head losses commensurate with both the initial conditions, and the potential future raised reservoir level scenario, must be satisfied. It is assumed that the turbine runners themselves would need to be replaced if the dam is raised, to maintain high overall unit efficiency. This methodology has been successfully used at other dam raises, such as that of Guri in Venezuela.

In the Railbelt system, currently units range in size from 3 MW to 88 MW, although some units may be grouped on busses, and act as a larger unit. Clearly, the Susitna-Watana units will be the largest on the system for the foreseeable future.

#### 7.5.4.3. Incremental Cost of Capacity

The incremental cost of capacity can be viewed from two perspectives, and both options were investigated:

- The incremental cost of installing larger units; and,
- The incremental cost of adding extra units.

7.5.4.3.1. Unit Costs

Water to wire costs have been derived from MWH’s database, which is kept up-to-date and includes all significant awards of turbines, generators and transformers in the world market. The quoted prices in Table 7.5-5 below are total water-to-wire cost for each unit, based on three alternatives: six units of 100 MW, four units of 150 MW, and three units of 200 MW, all rated at an operating level of El. 1950 ft., and 3 x 200 MW at maximum head. In each case it is assumed that the first unit is more expensive than the other similar units, but they have been normalized for the comparison.

**Table 7.5-5. Comparative Costs of Various Generating Equipment Combinations**

3 x 200 MW @ operating level El. 1950 ft.	US\$ 255,150,000
4 x 150 MW @ operating level El. 1950 ft.	US\$ 278,784,000
6 x 100 MW @ operating level El. 1950 ft.	US\$ 348,300,000
3 x 150 MW @ operating level El. 1950 ft.	US\$ 209,088,000

7.5.4.3.2. Associated Civil / Structural Costs

Using MWH’s proprietary parametric graphical drafting software, the dimensions of each type of unit have been derived and a “bay width” derived – as well as a penstock dimension. For each size of unit, power facilities have been drafted, and the typical output is shown in Figure 7.5-3 and Figure 7.5-4 for a 6 x 100 MW plant and for a 4 x 150 MW plant respectively.

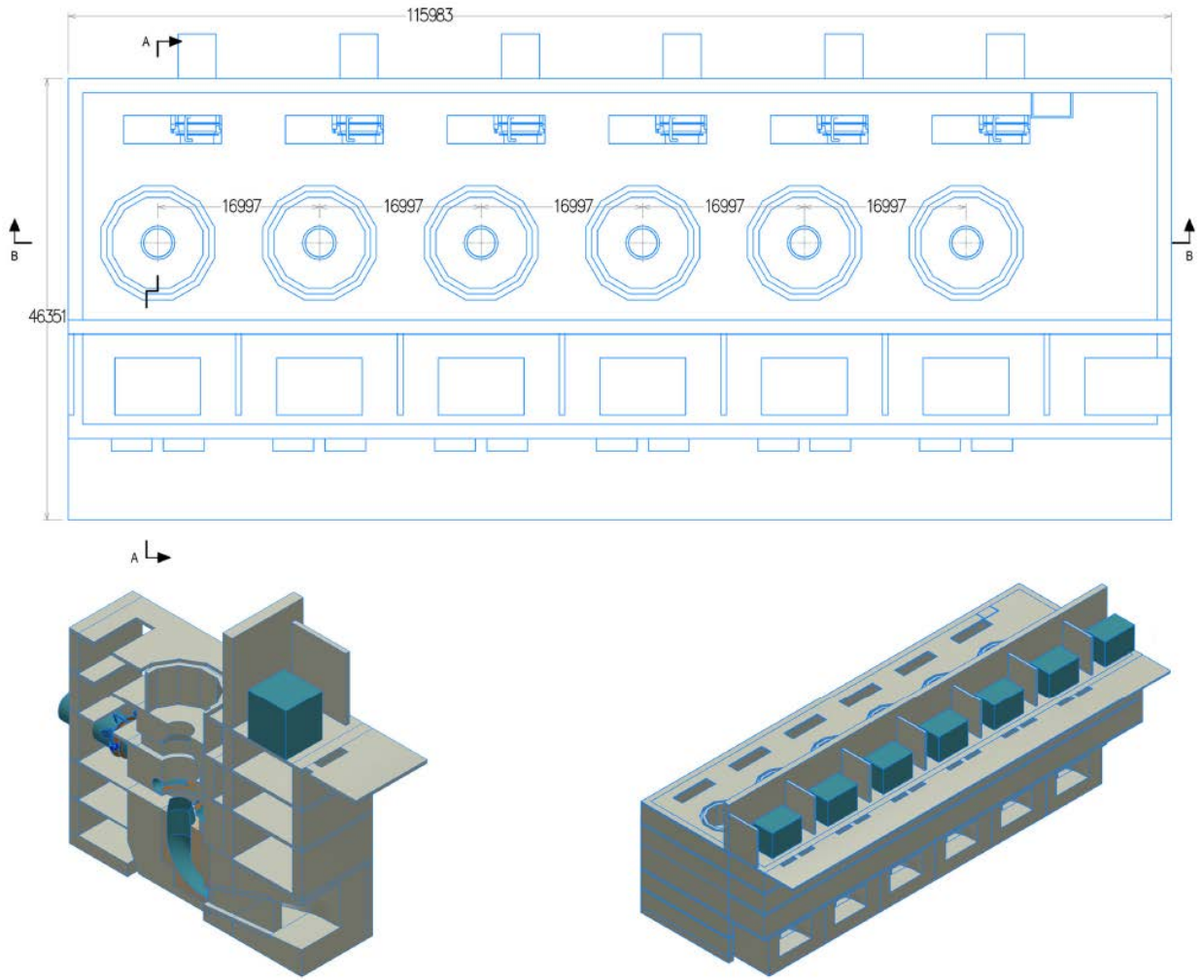

**Figure 7.5-3. Powerhouse for 6 x 100 MW Units (dimensions in millimeters)**

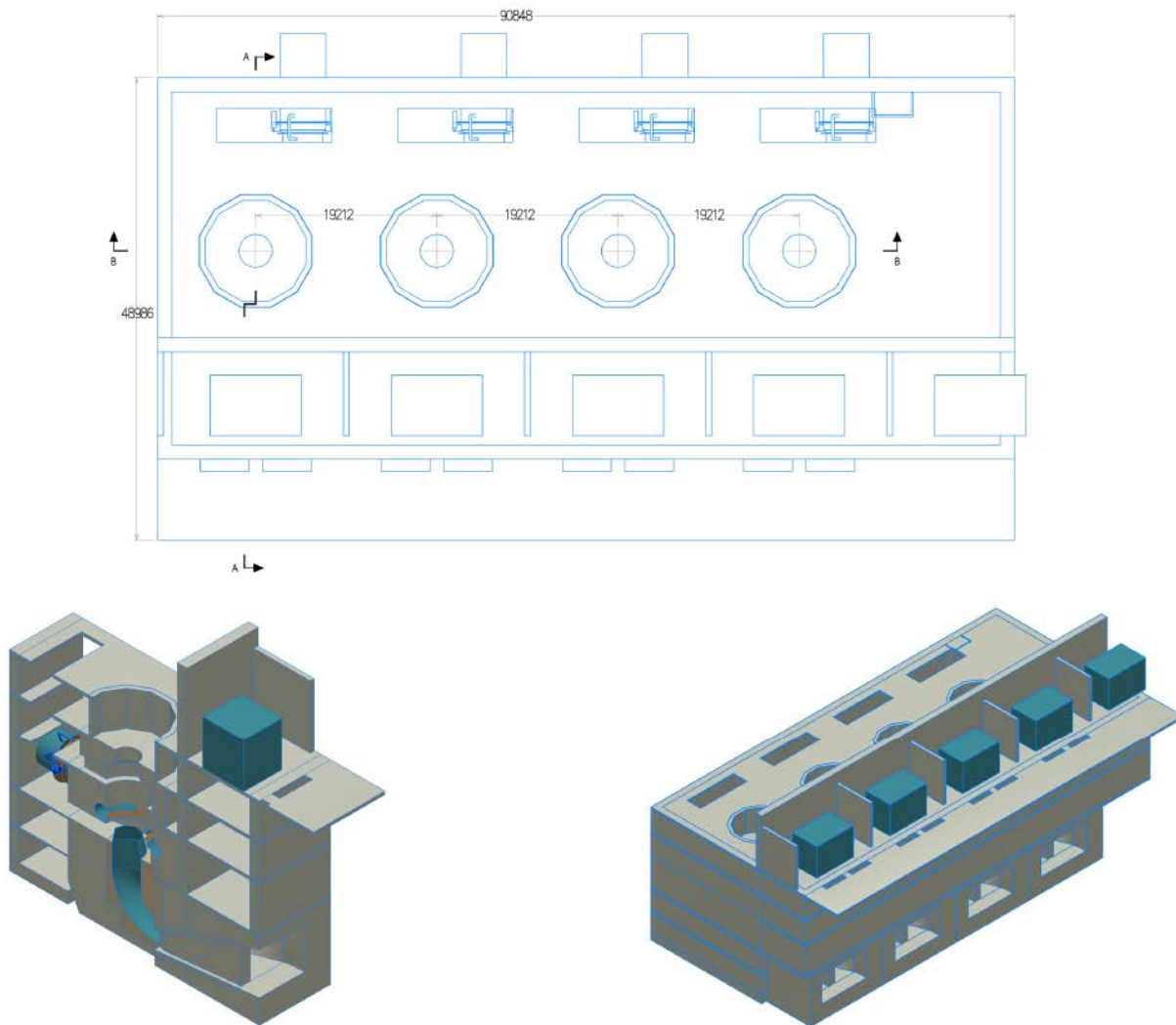

**Figure 7.5-4. Powerhouse for 4 x 150 MW Units (dimensions in millimeters)**

The software automatically generates quantities for comparison, and these have been used for comparison as recorded in Table 7.5-6 below. The total comparative civil cost has been derived for each option (assuming an erection bay of 1.5 times the bay width).

**Table 7.5-6. Comparative Civil Costs of Various Powerhouse Sizes**

Unit Size	Bay Width (ft.)	Civil Construction Cost (US\$)
200 MW @ average operating level El. 1950 ft.	72	329,466,647
150 MW @ average operating level El. 1950 ft.	62	380,086,494
100 MW @ average operating level El. 1950 ft.	52	488,326,131
150 MW @ operating level El. 1950 ft.	62	296,615,325

7.5.4.3.3. *Comparison of Total Construction Costs for Each Unit Size*

The comparison of estimated cost for the three sizes of unit (without application of camp costs and other establishment costs) are shown in Table 7.5-7 below:

**Table 7.5-7. Comparative Costs of Various Powerhouse and Unit Size Combinations**

Unit Size	Civil Construction Cost (US\$)	E&M Cost (US\$)	Total Costs (US\$)	Incremental Cost Difference
3 x 200 MW @ operating level El. 1950 ft.	329,466,647	255,150,000	584,616,647	1.16
4 x 150 MW @ operating level El. 1950 ft.	380,086,494	278,784,000	658,870,494	1.30
6 x 100 MW @ operating level El. 1950 ft.	488,326,131	348,300,000	836,626,131	1.65
3 x 150 MW @ operating level El. 1950 ft.	296,615,325	209,088,000	505,703,325	0

The current total estimated construction cost of the Project is of the order of US\$ 5.655 billion in 2014 dollars, while the total cost of the generating units and powerhouse is about US\$ 0.408 billion. The results of the analysis of the total costs of the different sized units shows that – if normal contractor “markups” are applied – the incremental cost differential associated with installing the larger units – compared to the smaller units – represents just under two percent of the total project construction cost. These costs do not include the cost of BESS – because the overall estimated project costs do not include for BESS costs, but if the additional cost of the slightly larger BESS units required for the larger units were included, the incremental difference in using the larger units would increase to very slightly over two percent of the total project cost.

7.5.4.3.4. *Operational Aspects of Unit Size*

First, as discussed in Section 7.4.2.1, large hydro units are typically more reliable than thermal units, by a factor of about two. However, detailed industry reliability statistics are not readily available for hydro units to such an extent as to enable assessment of the long-term availability differential between generating units sized at 100 MW, 150 MW, or 200 MW to allow determination of the optimum unit size for this study.

However, there is a body of experience related to O&M costs associated with plants of this size, sufficient to indicate that these costs are generally in proportion to the number of generating units installed. Put in other words, generally speaking the more units the higher the long-term O&M expenditures will be for a hydro plant of given capacity. This is assumed to be due to the increased maintenance associated with the increased number of working parts subject to wear and tear, and the more complex controls associated with the increased volume of plant equipment.

Generally the most efficient range of operation of a Francis turbine is between approximately 70 percent gate opening and 90 percent gate opening, representing (ignoring the small variation in efficiency over the range) approximate outputs of 140 MW to 180 MW for a 200 MW unit, 105 MW and 135 MW for the 150 MW unit and 70 MW to 90 MW for a 100 MW unit.

Second, given that there is a concern that a trip of a large hydro unit at the Susitna-Watana Project would destabilize the Railbelt system, operational rules might be established so that for the early years of the project use – before any load growth of the Railbelt system – the effects of a unit trip could be mitigated. Examples of rules that might be included in the power facilities operations are:

- Whenever possible, operate the Susitna-Watana Project units in pairs splitting the required output so that if one unit trips, the other Susitna-Watana Project unit can pick up the majority of the load.
- Maintain Susitna-Watana units or other Railbelt system generating units at varying stages of spinning reserve, again to pick up load quickly if one Susitna-Watana Project unit trips.
- Based on system load studies, adjust the under frequency trip points of all the key generating units on the Railbelt system, so that cascading trips do not result from trips of a Susitna-Watana unit.

Third, the project life is expected to be at least 100 years, with an expected refurbishment of the major electrical and mechanical components after 40 to 50 years of service (or approximately in 2065–2075). It is very difficult to predict the societal conditions and energy demand 60 years hence, but history shows – in general – a continuing long-term upward trend in energy consumption that often accompanies an increase in population and/or an increase in standard of living.

This being the case, it should be recognized that the inclusion – in a major capital project such as the Susitna-Watana Project – of design features that will not preclude expansion, but that will facilitate expansion, may well provide long term significant benefits even though during the first years of operation such features will not be of significant value. Experience around the world demonstrates that additional capacity at hydro projects is an economically attractive option for a majority of utilities because of the flexibility of the resource and the balance of total project costs between civil costs and electrical and mechanical costs – which is sharply biased towards the initial high cost of the civil structures that retain the reservoir. With the civil / structural provisions for future expansion already in place, the incremental cost of additional hydropower generating equipment is relatively low, and so this often proves to be the most economically attractive option for system capacity expansion.

The preliminary designs incorporate features that have small incremental civil/structural cost, but which will provide an opportunity for a future generation of Alaskans to gain significant added value from the project if they choose to do so when demand for additional generation occurs. Such features include:

- A spare unit bay in the powerhouse and a fourth penstock “stub” so that an additional unit can be added easily;
- Capacity in the installed units above what is predicted to be necessary at the projected in-service date as long as the restriction imposed on operation – to protect the system from disruption – are acceptable;
- Allowing sufficient space at the downstream side of the dam to allow for raising of the dam by up to 135 ft.; and,
- Sizing and design of the proposed generating units such that they could accommodate increased hydraulic head if necessary.

Any increase in capacity or significant dam modifications would be the subject of debate during relicensing in 50 years’ time, or would be the subject of a license amendment application to FERC at any time. Incorporating the potential for expansion of the project does not prejudice any decision that FERC would make at some future date.

### **7.5.5. Discussion and Selected Configuration**

Although it is possible to install a wide range of generating capacities and unit sizes at a hydroelectric powerhouse, installed capacities tend to fall within established ranges depending on the type of reservoir and operating mode associated with the project. In an isolated electric system such as the Railbelt, specific power requirements dictate the peak capabilities of the generating units.

For the Susitna-Watana Project, the installed capacity was verified primarily based on (1) annual average generation, and (2) on the maximum hourly power output for each month that would be required. As determined by an hourly system production costing model (PROMOD; see Section 12), the maximum hourly economic generation from Susitna-Watana would vary from about 285 MW to about 495 MW, depending on the time of year. With a powerhouse capacity of 600 MW at the maximum power pool level, the required Susitna-Watana generation can be met with high reliability. Therefore, 459 MW at operating level of El. 1950 ft. was selected as the installed turbine capacity for the Susitna-Watana Project powerhouse (equivalent to a generator output of 446 MW), acknowledging that the project may need some additional support from thermal generating units during unusually dry hydrologic sequences.

In contrast – and assuming that appropriate mitigation for potential system disruptions from large unit trips can be incorporated – selection of a total plant capacity of approximately 600 MW at the average water level would provide for occasionally higher hourly generation at very little extra cost. Increasing the installed capacity would not provide any significant additional annual energy, but it could rearrange the generation into higher hourly peaks, with corresponding reduction in generation during other hours, if that capability is deemed desirable.

After using sizing software, the selected hydraulic turbine units have been determined to have a rated capacity of 153 MW at operating level El. 1950 ft. This selection results in the following overall unit performance:

**Table 7.5-8. Selected Unit Ratings**

Reservoir Level	Turbine Rating (MW)	Generator Rating (MW)	Transformer Rating (MW)
Maximum normal operating level (El. 2050 ft.)	206.2	202.1	200
Average operating level (El. 1950 ft.)	153.1	148.5	147.0
Minimum operating level (El. 1850 ft.)	105.1	101.9	100.7

With proper predictive operation discussed above and in Section 12, such units could be used in a manner that would minimize spilling, and would achieve a minimum power contribution of about 300 MW at minimum operating level.

Although the project has been configured in accordance with the above recommendation, the incremental costs of using slightly bigger units (200 MW @ average operating level) has been demonstrated, and AEA should consider installing such units in readiness for increased operating flexibility for Railbelt load increases during the 100 year project life. In addition, the spare bay will give flexibility for future generations to obtain more benefits from the resource.

The analyses of installed capacity and unit size conducted to date can potentially be refined in a number of ways to:

- Incorporate any shift of spinning reserve to Susitna-Watana from Bradley and other plants, freeing them to use more of their capacity for peak shaving;
- Reflect any system rules for dispatch resulting from utilities agreements;
- Reflect any intended system redundancy being located at Susitna -Watana;



- Incorporate firming of any significant future wind generation that may be built in the Railbelt system; and,
- Lower carbon emissions by substitution of Susitna-Watana Power for fossil-fuel generation.

Most of these adjustments would tend to drive an increase in the installed capacity, as could more detailed PROMOD runs over a longer period – closer to the hydrological modeling period of 61 years. Accommodation of the potential for load growth beyond the currently maximum projected one percent and the expected greater use of hydro in the future (similar to most other large hydro) would also drive for a larger installed capacity or the need to provide in the design and construction for a relatively (technically) straightforward capacity increase at some undefined time in the future.

## **7.6. Project Configuration Evaluation**

### **7.6.1. Dam**

#### *7.6.1.1. Type*

In the 1980s, the height of dam proposed at Watana (approximately 705 ft.) limited the choice of dam type. The only types of dam that had been constructed to this height were concrete thin arch dams, concrete gravity dams, and earth core rockfill dams. The selected type of dam for the 1980s license application was an earth core rock fill dam (ECDR).

Since 1980, numerous concrete-faced rockfill dams (CFRD) and RCC gravity dams have been constructed throughout the world in the size range contemplated for Susitna-Watana Hydro. Both dam types are suitable candidates for the new Watana Dam initiative. There has been more frequent use of CFRD, often in highly seismic regions, for increasing dam heights, culminating in the Shuibuya Dam in China, which is currently the highest of its type at 233 meters (765 ft.). During earlier periods of dam building, compared to embankment dams, concrete gravity dams built in the traditional manner with conventional concrete placement have usually been more expensive. However, since the 1980s the efficient placement of concrete using RCC methodology has been perfected, and is now a proven, mature and economic technology. More than 550 RCC dams have been constructed worldwide, with heights ranging to over 700 ft. Other such dams – higher than the Watana Dam are currently in the planning and construction stages as well. With the precedent established – for all three types of dams possible at the Susitna-Watana site – an initial engineering study task was performed to compare the costs of the project using, as a basis, the following three types of dam: ECDR, CFRD, and RCC.

### 7.6.1.2. *Seismic Performance*

All types of dam considered are safe for a project located in a seismic region unless there is movement along a geological structure within the dam foundation – and the adopted design criteria will be crafted according to the expected seismic loads. As discussed, the possibility of co-seismic movement along a feature in the foundation would render an ECRD as more favorable which is why site investigations have focused on clarifying that such movement will not occur. Recent performance of dams in China is relevant. On May 12, 2008, an M8.0 earthquake occurred in Sichuan province, China. The focal depth of the earthquake was 2.8 miles and the maximum peak ground acceleration (PGA) experienced was 0.98g horizontally and 0.97g vertically. Four dams higher than 325 ft. have been completed (and are in operation) in the region near to the earthquake epicenter, and all experienced significant ground motions. The nearest two dams are Zippingpu, a 510 ft. high CFRD located 10 miles away, and Shapai, a 432 ft. RCC thin arch dam, 22 miles distant.

The Shapai dam experienced slight opening of the joints on the right side and the grouting and drainage galleries were flooded because of blockage of the river downstream of the dam. No other damage was sustained. A local landslide also affected the spillway tunnels outlets. All four dams in the vicinity remained structurally intact following the earthquake and there was no uncontrolled release of water from their respective reservoirs.

The crest of the Zippingpu dam settled by 2.66 ft., with an associated seven-inch downstream movement. Foundation seepage increased from 2.6 to 5.3 gallons per minute following the event and the concrete facing joints slipped 13.8 inches vertically and 6.7 inches horizontally.

### 7.6.1.3. *Comparative Cost Estimate*

The comparison of the three types considered for Watana dam was performed by estimating the construction costs of the dam and all facilities that are unique to each dam type. All items that are common, such as spillway gates, turbine and generators, switchyard, transmission line, and access road were excluded from the comparison. Thus, the costs quoted in this section do not constitute complete “project” cost estimates, but rather, comparative cost estimates for the dam component.

Although the overall project layouts for an ECRD and CFRD, which are both based on an embankment, are very similar, the arrangement using an RCC concrete gravity structure is significantly different. A concrete gravity structure allows for a much more compact structure, with penstocks through the dam, a spillway over the dam, and a powerhouse at the toe of the dam; advantages that can mitigate the comparatively high cost of the RCC itself.

At a later stage in the exercise – when the first comparative layouts had been estimated – the extent of the contribution (to reduction in cost) of a surface powerhouse was explored. This question was raised because the RCC configuration was the sole layout that included a surface powerhouse. It was therefore decided to draft a fourth configuration, based on a surface powerhouse and a CFRD. To accommodate this arrangement, the required power tunnels would have to be constructed on the opposite (south) side of the river to the diversion tunnels, and a substantial excavation would be required to allow the powerhouse construction to commence independent of the cofferdams and diversion tunnels and cofferdam construction.

The cost of this alternative, which has been included in Table 7.6-1, is some \$201,420,000 higher than the RCC alternative. Key Items driving the cost difference include a twin power tunnel and gate shafts and the excavation required to construct the powerhouse on the left side of the river. The intake structure for this alternative is also complex and further drives up the cost of the alternative. A similar concept was not prepared for the ECRD alternative since its total cost for the basic alternative (including an underground powerhouse) was substantially greater than the similar concept using a CFRD layout.

A separate layout was drawn for each type of dam and detailed as necessary to determine the basic unit quantities associated with each development.

Quantities were derived for the four developments and an estimate (of the non-common items) was made and compared. A summary of the comparative estimates is shown in Table 7.6-1.

**Table 7.6-1. Summary of Comparative Costs**

Alternative	Amount (US\$)	% increase relative to lowest
RCC	1,730,500,000	0
CFRD Surface powerhouse	1,931,920,000	11.6
CFRD U/G Powerhouse	1,959,300,000	13.2
ECRD	2,325,410,000	34.4

#### 7.6.1.4. *Water Resources Assessment Methodology*

Although the cost comparison shown in Table 7.6-1 is compelling, it is recognized that cost is not the sole determinant in the choice of project configuration, so other non-cost factors were also compared based using the Water Resources Assessment Methodology (WRAM) method. The WRAM method is based on two parallel judgments:

1. The creation of a list of attributes of importance. In the case of Watana Dam the following attributes were selected; ease of raising; seismic resistance; risk of price

increase; visual intrusion; possibilities of acceleration; cold weather construction; potential for design optimization; the accommodation of any environmental mandates; and the long-term cold weather performance. Weightings or “Relative Importance Coefficients” were assigned by the engineering team to each attribute as a decimal, the total of which must be unity. (For some applications, the weighting can be selected by using the pair comparison discussed below.)

2. Following the determination of the weightings or RIC, the three basic alternatives (this comparison was performed before the derivation of the CFRD with a surface powerhouse) were compared on a pair-by pair basis for each of the attributes. A “dummy” was introduced to ensure that each alternative scored at least one – necessary for the mathematical extensions. For each attribute, each of the alternatives was compared with every other alternative pair by pair to determine which was considered to be the “better”. The option considered to be better was assigned a value of one, and a value of zero was assigned to the other. If a decision could not be made regarding rank, or if both options were considered equal, a value of 0.5 was assigned to each.

For each attribute, the scores were multiplied by the weightings, and then the results were totaled to determine a total score. The pair comparisons were made by the project engineering team, and they also provided one set of weightings. However, a completely independent set of weightings was provided by MWH staff familiar with, but not performing assignments for the feasibility study. The summary of the WRAM analysis – which supports the choice of the RCC based alternative – is given in Table 7.6-2 (using the two different weighting).

**Table 7.6-2. Summary of WRAM Comparison**

Alternative	Weighted Score A	Weighted Score B
RCC	2.45	2.325
CFRD	1.9	1.98
ECRD	1.65	1.695

The alternative with the highest weighted score is the preferred alternative and Table 7.6-2 supports the conclusion that RCC is the preferred alternative for both weighted score assessments.

### **7.6.2. Diversion**

The diversion arrangements included in the comparisons differed slightly. For the ECRD, the river diversion works were sized to pass a flood with a return frequency of 1:50-years as determined in the 1980’s, equivalent to peak inflow of 89,500 cfs, using twin diversion tunnels. Routing effects are small; thus, at peak flow the diversion works would discharge 77,000 cfs.

The estimated maximum water surface elevation upstream from the cofferdam for this discharge would be El. 1532 ft.

The diversion arrangements for the CFRD are essentially the same except that because of the steeper slopes of the rockfill embankment for a CFRD, the cofferdams can be closer together, allowing the diversion tunnels to be 120 ft. and 550 ft. shorter.

For the RCC dam, although the cofferdam heights and type were (for the purposes of comparison) essentially the same, the distance between the upstream and downstream cofferdams was reduced considerably, from the 3,150 ft. for the ECRD, to 1,150 ft. Most importantly, the opportunity was taken to eliminate one of the diversion tunnels, and include a sluice through the dam to accommodate flood flows that would overwhelm a single tunnel.

### **7.6.3. Spillway**

For the comparison exercise, the spillway ogee and control structure were considered the same in all three alternatives. However, the spillway for the RCC dam was placed over the dam, which eliminated the considerable excavation of the approach channels and spillway chute required for the embankment dam alternatives. It is acknowledged that the joint between the conventional concrete of the spillway and the RCC body of the dam is a critical technical detail and care should be taken in the final design and detailing of this joint.

### **7.6.4. Power Facilities**

The ECRD and CFRD layouts considered the use of an underground powerhouse arrangement. The overall layout costed is generally similar to that proposed in the 1980s license application with the exception that three turbines are proposed with the potential to add another unit in the future. In contrast, a surface powerhouse would be an integral part of the layout of the RCC alternative. The powerhouse for the RCC variant would be located at the downstream toe of the dam, which has several advantages in terms of construction and cost. As noted above, a surface powerhouse arrangement would also be feasible for the embankment dam options, but would require more underground works arising from the penstock tunnels.

Following the initial screening of the three dam types, an outline assessment was prepared for a surface powerhouse associated with the CFRD alternative.

The surface powerhouse arrangement (at the toe of the dam) possible for the RCC layout allows for very short penstocks (through the dam) together with intake structures on the face of the dam. In contrast, the embankment dam options require long penstock tunnels and large and deep approach channels, as well as large freestanding intakes.

As noted, an option of a surface powerhouse at the south bank of the river (rather than at the toe of the dam) was also drafted. However, such an arrangement needs even longer penstock tunnels and substantial rock cut at the back of the powerhouse, raising costs compared to the chosen option.

#### **7.6.5. Summary of Comparison and Selection of RCC**

The comparative cost exercise indicated that the CFRD with a surface powerhouse would have costs within 12 percent of the RCC dam. However, the CFRD layout includes more risk associated with underground works compared to the RCC variant. It also includes risks and costs associated with the unconventional intake, and the significant excavation costs associated with optimizing the location of a powerhouse.

The construction schedules for the configurations examined at this stage indicate that the RCC alternative would require a seven and a half year construction program while the CFRD alternative would require an additional two years of construction schedule. The two-year saving in construction would enable AEA to commence generation earlier thereby start to receive revenue at an earlier stage.

The application of the WRAM approach to the evaluation exercise confirmed the RCC alternative to be the most attractive option even after a sensitivity analysis was performed on the WRAM results by adjusting of the weighting factors.