

Veget

---

Biological Report 90 (18)  
December 1990

# Federal Coastal Wetland Mapping Programs



QH  
540  
.U56  
no.90/  
18

---

fish and Wildlife Service  
Department of the Interior

## *Biological Report*

This publication series of the Fish and Wildlife Service comprises reports on the results of research, developments in technology, and ecological surveys and inventories of effects of land-use changes on fishery and wildlife resources. They may include proceedings of workshops, technical conferences, or symposia; and interpretive bibliographies.

Copies of this publication may be obtained from the Publications Unit, U.S. Fish and Wildlife Service, 1849 C Street, N.W., Mail Stop 130—ARLSQ, Washington, DC 20240, or may be purchased from the National Technical Information Service (NTIS), 5285 Port Royal Road, Springfield, VA 22161.

The publication of this report was funded, in part, by the National Oceanic and Atmospheric Administration's Coastal Ocean Program, U.S. Department of Commerce.

Biological Report 90 (18)  
December 1990

# Federal Coastal Wetland Mapping Programs

A Report by the National Ocean Pollution Policy Board's  
Habitat Loss and Modification Working Group

Edited by

Sari J. Kiraly

*National Oceanic and Atmospheric Administration  
Office of the Chief Scientist  
National Ocean Pollution Program Office  
1825 Connecticut Avenue, N.W.  
Washington, D.C. 20235*

Ford A. Cross

*National Oceanic and Atmospheric Administration  
National Marine Fisheries Service  
Southeast Fisheries Science Center  
Beaufort Laboratory  
Beaufort, North Carolina 28516*

and

John D. Buffington

*U.S. Fish and Wildlife Service  
Region 8, Research and Development  
1849 C Street, N.W.  
Washington, D.C. 20240*

U.S. Department of the Interior  
Fish and Wildlife Service  
Washington, D.C. 20240

# Contents

---

---

	Page
<b>Preface</b> .....	iv
<b>Federal Coastal Wetland Mapping Programs: Overview and Recommendations</b> <i>Sari J. Kiraly, Ford A. Cross, and John D. Buffington</i> .....	1
<b>National Programs</b>	
The U.S. Fish and Wildlife Service's National Wetlands Inventory. <i>Bill O. Wilen</i> .....	9
Coastal Barrier Resources System Mapping Process. <i>Mary C. Watzin</i> .....	21
National Oceanic and Atmospheric Administration's Habitat Mapping Under the Coastal Ocean Program. <i>James P. Thomas and Randolph L. Ferguson</i> .....	27
National Oceanic and Atmospheric Administration's National Coastal Wetlands Inventory. <i>Don W. Field, Anthony J. Reyer, Charles E. Alexander, Beth D. Shearer, and Paul V. Genovese</i> .....	39
Overview of the Land-Sea Interface Research Program. <i>Armond T. Joyce, Richard L. Miller, and Ramona E. Pelletier</i> .....	51
Enhanced Environmental Sensitivity Index Mapping Using Remote Sensing and Geographic Information System Technology. <i>Bruce A. Davis, John R. Jensen, Elijah W. Ramsey, III, and Jacqueline Michel</i> .....	59
Wetland Mapping Supported by the U.S. Environmental Protection Agency. <i>John R. Maxted</i> .....	61
U.S. Environmental Protection Agency's Environmental Monitoring and Assessment Program, an Ecological Status and Trends Program. <i>John F. Paul, A. F. Holland, Steven C. Schimmel, J. Kevin Summers, and K. John Scott</i> .....	72
Importance of Hydrologic Data for Interpreting Wetland Maps and Assessing Wetland Loss and Mitigation. <i>Virginia Carter</i> .....	80
The U.S. Geological Survey's National Mapping Division Programs, Products, and Services that can Support Wetlands Mapping. <i>Franklin S. Baxter</i> .....	88
Soil Conservation Service's Wetland Inventory. <i>Billy M. Teels</i> .....	94
<b>Regional and Federal-State Cooperative Programs</b>	
Coastal Mapping Programs at the U.S. Fish and Wildlife Service's National Wetlands Research Center. <i>James B. Johnston and Lawrence R. Handley</i> .....	106
Monitoring Seagrass Distribution and Abundance Patterns: A Case Study from the Chesapeake Bay. <i>Robert J. Orth, Kenneth A. Moore, and Judith F. Nowak</i> .....	112
Mapping Submerged Aquatic Vegetation in North Carolina with Conventional Aerial Photography. <i>Randolph L. Ferguson and Lisa L. Wood</i> .....	126

	Page
Project Plan for Mapping and Geographic Information System implementation of Land Use and Land Cover Categories for the Albemarle–Pamlico Estuarine Study. <i>H. M. Cheshire and Siamak Khorram</i> .....	135
Loss of Coastal Wetlands in Louisiana: Cooperative Research to Assess the Critical Processes. <i>S. Jeffress Williams and Asbury H. Sallenger, Jr.</i> .....	139
Marine Wetland Mapping and Monitoring in Florida. <i>Kenneth Haddad</i> .....	145
Satellite Data and Geographic Information Systems Technology Applications to Wetlands Mapping. <i>Richard H. Sinclair, Jr., Mark R. Graves, and Jack K. Stoll</i> .....	151
The Digital Wetlands Data Base for the U.S. Great Lakes Shoreline. <i>Michael Scieszka</i> ...	159
<b>Appendix. Habitat Loss and Modification Working Group</b> .....	<b>173</b>

# Preface

---

This report was prepared by the National Ocean Pollution Policy Board's Habitat Loss and Modification Working Group, which is an interagency technical committee established by the National Ocean Pollution Policy Board pursuant to recommendations contained in the current *National Marine Pollution Program Federal Plan for Ocean Pollution Research, Development, and Monitoring: Fiscal Years 1988-1992* (Federal Plan). The working group is jointly chaired by the National Oceanic and Atmospheric Administration's (NOAA) National Marine Fisheries Service and the U.S. Department of the Interior's Fish and Wildlife Service. The activities of the working group are coordinated through NOAA's National Ocean Pollution Program Office, which also directed preparation of the Federal Plan.

Understanding the effects of losing or modifying marine habitats as a result of human activities is one of six goals identified in the Federal Plan. The working group was charged with undertaking projects that would address recommendations outlined in the Federal Plan for achieving this goal at the Federal level, and to arrive at products that would be useful for Federal agencies planning and conducting habitat programs. Three study areas were selected: coastal wetlands mapping, coastal habitat loss, and wetland mitigation.

Examining the Federal effort in mapping the Nation's coastal wetlands was selected as the initial project because determining the current areal extent of these wetlands is fundamental to determining the actual rates and locations of loss. For this project, a workshop was conducted that included persons representing federally funded coastal wetlands mapping programs. The workshop took place in December 1989 at the U.S. Fish and Wildlife Service's National Wetlands Research Center in Slidell, Louisiana. The papers presented at the workshop are contained in this report. They are preceded by an overview of the major federally funded programs and the working group's conclusions and recommendations as to how the overall Federal effort in coastal wetlands mapping could be improved so that the status and trends of the Nation's coastal wetlands are documented in a timely fashion.

# Federal Coastal Wetland Mapping Programs

---

## Overview and Recommendations

by

Sari J. Kiraly

*National Oceanic and Atmospheric Administration  
Office of the Chief Scientist  
National Ocean Pollution Program Office  
1825 Connecticut Avenue, N.W.  
Washington, D.C. 20235*

Ford A. Cross

*National Oceanic and Atmospheric Administration  
National Marine Fisheries Service  
Southeast Fisheries Center  
Beaufort Laboratory  
Beaufort, North Carolina 28516-9722*

and

John D. Buffington

*U.S. Fish and Wildlife Service  
Region 8, Research and Development  
1849 C Street, N.W.  
Washington, D.C. 20240*

## Introduction

New legislative mandates and the increasing awareness of the value of wetlands have caused various government and private agencies to increase their efforts to study and manage these

areas. Fundamental to appropriate management is the development of a comprehensive data base that documents the extent, actual locations, and rates of loss of the Nation's remaining wetlands. Wetlands mapping provides an important basis for such a data base.

The manuscripts contained in this report describe what the Federal government is doing to map the Nation's coastal wetlands. Various aspects of a series of Federally funded programs are described, including the purpose and intent of the programs, technologies used, the type of data and other mapping products generated, and how the information is used. In this paper, we summarize the major programs and present the Habitat Loss and Modification Working Group's conclusions and recommendations for actions that could be taken to improve the effectiveness of Federal activities. We hope that this assessment of the various Federally funded coastal wetland mapping programs will reveal strengths, weaknesses, areas for improvement, and opportunities for better coordination among the Federal agencies and between Federal and State agencies as well.

## National Coastal Wetland Mapping Programs

Two Federal programs are designed to map coastal wetlands on a comprehensive, nationwide basis. These programs are conducted by the U.S. Fish and Wildlife Service (FWS) and the National Oceanic and Atmospheric Administration (NOAA).

### *The U.S. Fish and Wildlife Service*

The U.S. Fish and Wildlife Service's (FWS) National Wetlands Inventory (NWI) is the most extensive national wetlands mapping program. In addition to providing the most comprehensive inventory of the Nation's inland and coastal wetlands, it provides the basis for many other Federal and State mapping efforts. The NWI was initiated by FWS in 1975 to generate detailed wetland maps (based on Cowardin et al. [1979]), and reports on wetland status and trends.

By using conventional aerial photography, the NWI has produced over 30,000 wetland maps, including over 5,300 detailed 1:24,000-scale maps covering 100% of the coastal wetlands in the lower 48 States. The program is scheduled to complete wetland mapping of the conterminous United States by 1998, and mapping of Alaska will be completed as soon as practicable thereafter. In addition, 1% of the completed coastal wetland maps have been digitized for inclusion as a national mapping data-base category in the National Digital Data Base under the supervision of the

U.S. Geological Survey. Because the existing data base has been developed with user-pays funding, a completion date for digitizing all NWI maps cannot be set.

The NWI status and trends analysis was designed to document losses and gains in the Nation's wetlands. The national sampling grid for this analysis consists of stratified random samples of 3,635 4-square mile plots distributed within strata formed by State boundaries, physical boundaries, the coastal zone, and the Great Lakes. Plots are allocated to strata in proportion to the expected amount of wetland acreage. As legislatively mandated by the Emergency Wetlands Resources Act of 1986, a national status and trends report for the mid-1960's to the mid-1970's has been updated recently. Future updates are to be prepared every 10 years.

### *The National Oceanic and Atmospheric Administration*

As part of its Coastal Ocean Program, NOAA is developing a comprehensive, nationally standardized information system for land cover and habitat change in the coastal region of the United States. Satellite imagery, aerial photography, and surface geographic data will be interpreted, classified, analyzed, and integrated within a geographic information system (GIS). The program will delineate coastal wetland habitats and adjacent uplands, and will monitor changes in these habitats on a cycle of 1-5 years. Because maps will be spatially registered digital images, land cover change will be detected in a pixel by pixel (30- × 30-m pixels) comparison of different time periods, rather than by a comparison of stratified random samples. In addition, maps for a given period will be synoptic, based on satellite images or aerial photographs collected over short (days or weeks) time intervals. This type and frequency of information is required to determine the linkages between wetlands and the distribution, abundance, and health of living marine resources. Monitoring changes on a frequent basis will also allow appropriate management steps to be taken in a timely manner.

The Coastal Ocean Program mapping effort will build upon and complement ongoing mapping programs of other Federal and State agencies by using existing data to supplement field verification. Current efforts include a change analysis for 1984-1988 and 1989 for emergent coastal wetlands and adjacent uplands of Chesapeake Bay by using satellite imagery. Submerged aquatic vege-



tation in North Carolina is also being mapped by using aerial photography at scales of 1:12,000 and 1:24,000. The North Carolina study is being conducted cooperatively with the U.S. Environmental Protection Agency's (EPA) Albemarle-Pamlico National Estuary Program, and all maps are being digitized and placed in the State of North Carolina's GIS. The intent of the program is to eventually map all coastal regions of the United States.

Operational protocols for delimiting emergent and submergent coastal wetlands are being developed through a series of interagency workshops and meetings. Remote determination of biomass, productivity, and functional status of wetlands will be tested, as will new platforms and sensors as they become available.

## Other Federal Mapping Programs

### *The U.S. Geological Survey*

The U.S. Geological Survey (USGS) performs numerous mapping and mapping-related activities. The major base mapping effort is conducted by the National Mapping Division. Through its National Mapping Program, the division provides standard topographic maps at specified scales, as well as a diversity of cartographic, geographic, and remotely sensed data, products, and services, including wetlands information. Many Federal and State programs rely on the USGS's primary map series as a basis for site-specific wetland and other environmental studies. The program also provides technical assistance to Federal agencies in establishing their GIS capabilities for the development of wetlands data bases.

The National Mapping Division has prepared 1:24,000-scale topographic maps covering most of the Nation. Program emphasis has been shifted to revising the inaccurate and out-of-date maps of this series. In addition, development of a new series of land use and land cover maps at the 1:100,000 scale is being considered. Cooperative efforts with the U.S. Department of Agriculture Soil Conservation Service and the NWI should result in additional products to aid in the study of wetlands, including image base maps and state-of-the-art GIS's.

The USGS's Water Resources Division collects and disseminates, in written and digital formats, groundwater and surface water hydrological infor-

mation pertaining to tidal and nontidal wetlands. This information complements the two-dimensional information provided by wetlands maps.

The USGS's Geologic Division collects, interprets, and disseminates basic geological information on inland and coastal wetlands. Much of this information is displayed on thematic maps and includes data on the three-dimensional structure of wetlands, as well as how wetlands evolve and change through time.

### *The National Oceanic and Atmospheric Administration*

In 1989, NOAA's National Ocean Service and National Marine Fisheries Service completed a comprehensive Coastal Wetlands Inventory of estuarine drainage areas of the United States. The project used a 45-acre grid-sampling technique to quantify existing NWI wetlands maps that were based on aerial photographs from 1971 to 1985. Data were entered into a GIS data base that can display and calculate acreage summaries by NWI map, county, State, and estuary. The data base, which contains 5,290 NWI maps and presents data on 507 counties and 92 estuaries, has been useful in providing summaries of wetland distribution and abundance across large geographic areas. These data will be incorporated into NOAA's National Estuarine Inventory, a comprehensive data base useful for evaluating the health and status of the Nation's estuaries.

### *The U.S. Environmental Protection Agency*

Wetland mapping has been supported by the U.S. Environmental Protection Agency through the Clean Water Act Section 404 and Superfund programs. There are two basic types of wetland mapping activities under these programs: (1) comprehensive planning under the Section 404 program, referred to as "advance identification" (ADID), and (2) specific studies of certain identified Superfund sites. Site-specific mapping in the second context focuses on wetland boundary changes over time, generally as part of a criminal prosecution, and historical data often provide the goal for restoration of the site to its original condition. Mapping conducted under the ADID program is intended to steer development away from the most valuable wetlands.

The EPA is initiating an Environmental Monitoring and Assessment Program (EMAP) to char-

acterize the condition of the Nation's ecological resources on regional and national scales and over long periods. The wetland resource component of EMAP will develop a program to assess the status and trends of wetland condition and extent. The proposed EMAP sampling design calls for selection of 30 representative 40-km<sup>2</sup> sites within each of 11 near-coastal geographic regions. Each year, 25% of these sites will be visited; samples will be taken from plots within each site to determine habitat condition.

EPA's wetland mapping activities rely, to a large extent, on the mapping conventions developed by the NWI program, and in most instances use NWI maps and NWI mapping capabilities. For example, the EPA and FWS collaborate to produce reports describing the status and trends of wetland acreage (NWI) and condition (EMAP).

## Major Regional and Federal-State Cooperative Mapping Programs

### *The U.S. Fish and Wildlife Service*

The FWS's National Wetlands Research Center has an ongoing program in habitat mapping of wetlands, seagrasses, and uplands. Projects are developed in cooperation with other Federal and State agencies, such as the U.S. Army Corps of Engineers, EPA, and the Louisiana Department of Natural Resources. The wetlands center cooperates with the NWI and uses NWI procedures for photointerpretation, quality control, and quality assurance, and produces maps at several scales. In addition to wetland classification, these maps depict upland classification so that habitat change analyses can determine what type of uplands replaced wetland areas. The center also is developing wetland maps to include selected indicator species. Information gathered under the program has been used to develop digital data bases for various coastal areas. These data bases can be entered into the center's GIS to implement natural resource inventories, habitat trend analyses, and cartographic modeling projects.

### *The U.S. Geological Survey*

The USGS has an active National Coastal Geology Program that includes a number of research field investigations related to wetlands. The pro-

gram is currently focused on the severe loss of wetlands in Louisiana. In cooperation with the State of Louisiana and FWS, USGS is conducting field investigations on wetlands loss to identify natural and human-made causes. The USGS is also establishing a GIS network of providers and users of wetlands data in Louisiana. This system will probably be expanded to include the entire Gulf of Mexico region.

At the request of Congress, USGS recently prepared a study plan for conducting coastal and wetlands research to address gaps and needs in geologic information on wetlands evolution. The plan was prepared in close coordination with other Federal agencies and coastal States, and was submitted to Congress in June 1990. For fiscal year 1991, wetland studies are planned for Louisiana, Florida, the Great Lakes, and San Francisco Bay. All of these studies will be done in cooperation with State agencies.

### *The Chesapeake Bay Program*

The Chesapeake Bay Program is a joint effort among a number of Federal agencies and the States bordering the bay. Under this program, submerged aquatic vegetation (SAV) has been surveyed by the Virginia Institute of Marine Science. The Virginia Institute of Marine Science has mapped SAV on a baywide basis five times between 1978 and 1987, with standard aerial photographic techniques at a scale of 1:24,000. In addition, data from photointerpretation of the imagery have been entered and stored on a Virginia Institute of Marine Sciences's GIS. The result of these efforts is a temporal delineation of SAV that provides the basis for long-term trends analysis on the distribution and abundance of this resource in Chesapeake Bay.

### *North Carolina*

Under the Albemarle-Pamlico Estuarine Study (funded by EPA and the State of North Carolina), North Carolina State University's Computer Graphics Center is conducting a land use inventory of Albemarle and Pamlico sounds and their tributary basins. This inventory will include over two-thirds of North Carolina's coastal wetlands and will be prepared from remotely sensed satellite data. SAV data generated by NOAA under its Coastal Ocean Program also will be included in the inventory. The goal is to develop a digital land use and land cover inven-

tory of the entire Albemarle-Pamlico drainage area that can be maintained and updated as needed as part of the State's GIS.

### *Florida*

In 1983, the Florida Department of Natural Resources, Marine Research Institute began building a digital ecosystem data base through NOAA's Coastal Zone Management Program. Habitat mapping and trend analysis are key components of the effort. An efficient, cost-effective mapping program has been developed based on a combination of conventional aerial photography and satellite images. State-of-the-art techniques are used for image analysis, resulting in highly accurate maps. A data base for trend analyses also is being created by incorporating other contemporary and historical data with data collected under the program. All of the data will be incorporated into a GIS to use in implementing an ecosystem approach to coastal resource management.

### *Michigan*

The Michigan Resource Inventory Program has prepared a detailed land cover and land use inventory that includes a set of wetland maps. The inventory used conventional infrared aerial photography, primarily on a 1:24,000 scale, for its mapping effort. In addition, digital products have been prepared from the data and incorporated into the Michigan Resource Information System. The data collection and digital processing methodology, as well as the products generated, are being used by the International Joint Commission.

## **Conclusions and Recommendations**

### *The Federal Effort*

Although many mapping programs are under way, a centralized and standardized national digital mapping data base of coastal wetlands is not available and needs to be developed. Various Federal agencies conduct programs to document coastal wetland acreage. Some of the programs are on a nationwide scale; others are regional. Methodology, frequency, and degree of resolution may vary, primarily based on purpose, technology availability, and intended use of the products. A georeferenced and computerized data

base that provides information on wetland habitat changes in a variety of forms (e.g., statistical and mapped) has been identified by Federal agencies and others as an important tool for decision makers in administering coastal programs. A standardized and centralized data base will allow data collected by different programs under varying legislative mandates to be incorporated into individual GIS's to suit user needs, and the data can be readily updated to reflect current information.

Because of the value of FWS's National Wetland Inventory, it is important that it continue and that an effort be made to digitize the available coastal wetland information. At the Federal level, the NWI is the most comprehensive nationwide mapping program, providing detailed maps of wetland distribution, including those in the coastal zone. The NWI is a valuable resource that serves not only as a useful data base both within the Federal and private sectors, but also as the basis of many other Federal and State mapping programs. The status and trends analysis component, which is based on a stratified random sample, may not be suitable for assessing trends at the local level, but is appropriate for assessing trends on a national scale.

Because it is critical that changes in coastal wetland acreage be monitored on a timely basis so that appropriate management strategies can be implemented or existing strategies modified, particularly in areas of rapid habitat loss, the national mapping effort needs to be accelerated. It is also essential that the implications of change on coastal ecosystems, including living marine resources, be evaluated while documenting the location and acreage of the Nation's coastal wetlands. Documentation should be done both at the national level, to assess the overall status and trends of the Nation's coastal wetlands, and at the regional or local level so that more detailed assessments can be made.

More focused research is needed to support the development of cost-effective, state-of-the-art mapping technologies with detailed digital satellite images and aerial photographs. We anticipate these newer technologies will make it possible to map coastal areas more frequently and accurately, which will provide more up-to-date information for decision makers.

It is particularly important that high-resolution, georeferenced digital data bases for critical habitat types, based on standard protocols and synoptic images, be developed. Such data bases would allow comparison of chron-

ological digital data to assess both national and local trends in wetland coverage. Developing a standardized set of protocols for extracting digital information on wetlands coverage from satellite images and aerial photographs is fundamental to such an effort. NOAA's Coastal Ocean Program is developing standardized protocols to produce georeferenced, digital data bases and digital maps from satellite images. The NOAA program is confined to the coastal zone and, in part, relies on NWI maps for ground truthing of satellite images. This effort, which complements rather than duplicates the NWI effort, should continue.

**Because of the relative importance of submerged aquatic vegetation (SAV) to coastal ecosystems, a Federal initiative should be developed to standardize SAV mapping and to provide a national data base.** Currently, mapping is being conducted by the State of Florida, the Chesapeake Bay Program, and NOAA's Coastal Ocean Program for the North Carolina coast. In 1991, EPA will begin mapping SAV in the Gulf of Mexico. However, SAV is not being mapped consistently on a national scale. In addition, standard protocols for mapping SAV, such as those being developed by NOAA's Coastal Ocean Program, are needed and should be instituted for future mapping programs.

**Fundamental cartographic information, such as that developed by USGS and NOAA, needs to be updated, particularly for areas where shorelines have eroded or accreted substantially.** Also, coordination and maintenance of the national data bases, which provide standardized and uniform quality photographic coverage of the 48 conterminous States on a 5-year acquisition cycle, should be continued. In addition, existing cartographic, geologic, and hydrographic information should be digitized and collated into a coastal wetland GIS.

### *Federal and State Coordination*

**Coordination among the Federal agencies should continue, and efforts should be made to identify additional opportunities for cooperative mapping programs.** Coastal wetland mapping programs are being conducted by Federal and State agencies for a variety of purposes, and at different levels of resolution. It is important that these efforts be coordinated, not only because no single program can meet all user needs, but also so that duplication of effort, wasteful resource allocation, and incompatibility of data can be minimized.

Currently, considerable coordination among Federal agencies exists. One example of coordination activities is the cost-sharing agreements between the NWI and many Federal and State agencies. In addition, interagency coordination was important in preparing NOAA's Coastal Wetlands Inventory, which was based on maps prepared as part of the NWI. Habitat mapping under NOAA's Coastal Ocean Program is another example of an integrated Federal agency effort that will result in a comprehensive data base for the Nation's coastal wetlands and will provide timely information for documenting trends in wetlands and SAV acreage.

**Coordination among Federal, State, regional, and local levels needs to be improved.** A number of Federal mapping programs are already coordinating efforts with State agencies (e.g., FWS's National Wetlands Research Center coastal mapping projects, USGS coastal erosion and wetland loss projects, EPA's Albemarle-Pamlico Estuary Program, and NOAA's Coastal Ocean Program). However, Federal cooperation with State mapping projects should be increased and national protocols developed so that State mapping efforts can be integrated with, and complement, other regional and national projects. Ultimately, coordination and cooperation at this level will allow the development of a comprehensive data base of coastal wetland habitats and could provide the model for continued coordination efforts for other habitat types. An example of such an effort is the Michigan Resource Inventory Program, which is coordinating with the U.S. Army Corps of Engineers and the International Joint Commission in making its data available. A possible mechanism for improved coordination of programs at the State level is the Coastal Zone Management Program administered by NOAA. Also, the coastal mapping and change analysis protocols being developed by NOAA's Coastal Ocean Program could provide the vehicle by which standardization of methodology and data generation could occur.

**Existing mechanisms for coordinating agency programs could be used for developing a consensus on how Federal agencies should be planning and promoting research on state-of-the-art wetlands mapping technology. In addition, these coordination mechanisms should be used to aid in the identification of additional mapping efforts that are needed, and to promote even closer coordination and interaction among the coastal mapping programs.** One existing mechanism is the interagency National Ocean Pollution Policy

Board, which addresses Federal agency coordination for marine (including coastal) pollution research and monitoring. Another mechanism is the Office of Management and Budget's Circular A-16, which, as revised, provides for the establishment of an interagency committee to promote the coordinated development, use, sharing, and dissemination of surveying, mapping, and related spatial data. The President's Domestic Policy Council Task Force on Wetlands, which is charged with developing a national policy for attaining no net loss of wetlands, is another potential mechanism for interagency cooperation. Finally, multiagency initiatives for developing coastal management strate-

gies, built upon existing programs, legislative mandates, and management expertise, should provide a framework for identifying and implementing coordinated mapping efforts at the national and regional levels.

## Reference

- Cowardin, L. M., V. Carter, F. C. Golet, and E. T. LaRoe. 1979. Classification of wetlands and deepwater habitats of the United States. U.S. Fish Wildl. Serv., FWS/OBS-79/31. 103 pp.

# National Programs

---

## The U.S. Fish and Wildlife Service's National Wetlands Inventory

by

Bill O. Wilen

*U.S. Fish and Wildlife Service  
National Wetlands Inventory  
400 Arlington Square  
Department of the Interior  
18th and C Streets, N.W.  
Washington, D.C. 20240*

**ABSTRACT.**—In 1974, the U.S. Fish and Wildlife Service directed its Office of Biological Services to design and conduct an inventory of the Nation's wetlands. The mandate was to develop and disseminate a technically sound, comprehensive data base concerning the characteristics and extent of the Nation's wetlands. This data base should be used to foster wise use of the Nation's wetlands and to expedite decisions that may affect this important resource. To accomplish this, state-of-the-art principles and methodologies pertaining to all aspects of wetland inventory were assimilated and developed by the newly formed project. By 1979, when the National Wetlands Inventory (NWI) Project became operational, it was clear that two very different kinds of information were needed. First, detailed wetland maps were needed for site-specific decisions. Second, national statistics developed through statistical sampling on the current status and trends of wetlands were needed to provide information to support the development or alteration of Federal programs and policies.

---

### Authorization

The Emergency Wetlands Resources Act of 1986 directs the Secretary of the Interior, through the Director of the U.S. Fish and Wildlife Service, to produce by 30 September 1990, and at 10-year intervals thereafter, reports to update and improve the information in the report *Status and Trends of Wetlands and Deepwater Habitats in the Conterminous United States, 1950's to 1970's* (Framer et al. 1983). This act also requires the Fish and Wildlife Service to produce, by 30 September 1998, National Wetlands Inventory maps for the remainder of the contiguous United States and, as

soon as practicable thereafter for Alaska and non-contiguous portions of the United States.

### Introduction

The Fish and Wildlife Service (FWS) has always recognized the importance of wetlands to waterfowl and other migratory birds, in part because 10–12 million ducks breed annually in the United States, and millions more overwinter here. Consequently, FWS has a direct interest in protecting wetlands, especially wetlands where waterfowl breed and overwinter.

We know that wetlands also play an integral role in maintaining the quality of human life through material contributions to the national economy (through the food supply, water supply and water quality, flood control, and fish, wildlife, and plant resources) and thus to the health, safety, recreation, and economic well-being of all United States citizens.

### *Need for a National Wetlands Inventory*

In 1954, the FWS conducted a nationwide wetlands survey that focused on important waterfowl wetlands. This survey covered roughly 40% of the lower 48 States. Although this survey was not a comprehensive wetlands inventory by today's standards, it was instrumental in stimulating public interest in the conservation of waterfowl wetlands. These findings were published in a well-known FWS report *Wetlands of the United States*, commonly referred to as *Circular 39* (Shaw and Fredine 1956).

Since this survey, however, wetlands have undergone many changes, both natural and human-induced. These changes, coupled with an increased understanding of wetland values, led FWS to establish the National Wetlands Inventory (NWI) Project. The NWI goal is to generate and disseminate scientific information on the characteristics and extent of the Nation's wetlands. We hope this information will foster wise use of the Nation's wetlands and provide data for making quick and accurate resource decisions. Decision makers are not able to make informed decisions about wetlands without knowing how many wetlands, and of what type, are where.

### *Needed Wetland Information*

Two different kinds of information are needed: detailed maps and status and trends reports. Detailed wetland maps are needed for assessing the effects of site-specific projects. These maps serve a purpose similar to the Soil Conservation Service's soil survey maps, the National Oceanic and Atmospheric Administration's coastal geodetic survey maps, and the U.S. Geological Survey's topographic maps. Detailed wetland maps are used by local, State, and Federal agencies—as well as by private industry and organizations—for many purposes, including comprehensive resource management plans, environmental impact assessments, facility and corridor siting, oil spill contin-

gency plans, natural resource inventories, and habitat surveys.

National estimates of the current status and trends (i.e., losses and gains) of wetlands, developed through statistical sampling, also are needed. These estimates will be used to evaluate the effectiveness of existing Federal programs and policies, identify national or regional problems, and increase general public awareness of wetlands.

## **Pre-operational Phase**

Before actually beginning wetland mapping in 1979, the National Wetlands Inventory Project reviewed existing State and local wetland inventories and existing classification schemes to determine the best way to inventory wetlands. Researchers determined that a remote sensing technique would be the best method to inventory wetlands.

### *Review of Existing Wetland Surveys*

The first step of the pre-operational phase was to review existing wetland inventories. The NWI consulted with Federal and State agencies to learn where and when wetland surveys had previously been completed, what inventory techniques were employed, where to obtain copies of any wetland maps that may have been produced, and the status of State wetland protection. Only a handful of States had inventoried their wetlands, and most of these had only mapped coastal wetlands. These results were published in a 1976 FWS report (U.S. Department of the Interior 1976).

### *Review of Existing Classification Systems*

Before the inventory could begin, NWI researchers had to decide how to classify wetlands. Thus, in 1975, FWS brought together 15 of the Nation's top wetland scientists to evaluate the usefulness of existing wetland classification schemes for the National Wetlands Inventory. These scientists determined that none of the existing systems could be used or modified for the NWI and that a new classification system should be developed.

### *Development of a New Wetlands Classification System*

The FWS's wetlands classification system (Cowardin et al. 1979) was developed by a team of four

wetland ecologists, one each from the U.S. Fish and Wildlife Service, U.S. Geological Survey, U.S. National Oceanic and Atmospheric Administration, and the University of Rhode Island, with the assistance of local, State, and Federal agencies, as well as many private groups and individuals. The new system went through four major revisions and extensive field testing before its official adoption by FWS on 1 October 1980.

This classification system describes ecological units having certain common natural attributes, arranges these units in a system that aids resource management decisions, furnishes units for inventory and mapping, and provides uniformity in wetland concepts and terminology throughout the United States. Although it is not an evaluation system, it does provide the information upon which evaluations can be made.

Wetlands are extremely diverse and complex. The FWS classification system defines the limits of wetlands according to ecological characteristics and not according to administrative or regulatory programs. In general terms, wetlands are defined in Cowardin et al. (1979) as lands where saturation with water is the dominant factor determining the nature of soil development and the types of plant and animal communities living in the soil and on its surface.

This state-of-the-art wetland classification system presents a method for grouping ecologically similar wetlands. The system is hierarchical, with wetlands divided among five major systems at the broadest level: Marine, Estuarine, Riverine, Lacustrine, and Palustrine. Each system is further subdivided by subsystems that reflect hydrologic conditions, such as Subtidal versus Intertidal in the Marine and Estuarine systems. Below subsystem is the class level, which describes the appearance of the wetland in terms of vegetation (e.g., Emergent, Aquatic Bed, Forested), or substrate if vegetation is inconspicuous or absent (e.g., Unconsolidated Shore, Rocky Shore, Streambed). Each class is further divided into subclasses. The classification system also includes modifiers to describe hydrology (water regime), water chemistry (pH, salinity, and halinity), and special modifiers relating to human activities (e.g., impounded, partly drained, farmed, artificial).

Below the class level, the classification system is open-ended and incomplete. The dominance type is the taxonomic category subordinate to subclass. Dominance types are determined on the basis of dominant plant species, dominant sedentary or ses-

sile animal species, or dominant plant and animal species. Cowardin et al. only provide examples of the many dominance types possible. Those using this classification system are expected to identify these dominance types and use them as part of the hierarchical classification system. It is also probable that as the system is used in more detail to meet a user's site-specific needs, the need for additional subclasses and special modifiers will become clear.

This classification system has been adopted by many national and international organizations. Illinois, Michigan, and Oregon have passed State wetlands legislation that relies heavily on NWI wetland information for implementation. The NWI was the first phase of a long-range State wetland plan for Illinois. Indiana and Minnesota have wetlands legislation currently under consideration that will also depend heavily on NWI maps and digital data. The first International Wetlands Conference met in New Delhi, India, on 10–17 September 1980. Conference participants passed a motion to adopt this classification system.

### *Selecting a Remote Sensing Tool*

Because of the magnitude of the NWI, remote sensing was the obvious technique for inventory of the Nation's wetlands. The basic choice was between high-altitude photography and satellite imagery (Landsat). After comparing Landsat's capabilities with FWS's and other agencies' needs for wetland information, it was evident that Landsat could not provide the needed data for classification detail and wetland determinations within the desired accuracy requirements.

The National Wetlands Inventory Project has continued testing satellite technologies. Along with the National Aeronautic and Space Administration's Jet Propulsion Laboratory, NWI conducted a year-long test of the multispectral scanner to detect and map wetlands in Alaska. With Ducks Unlimited, NWI also tested Thematic Mapper data, as well as data from the French satellite called SPOT. A year-long test is now being conducted by the Earth Observation Satellite Company to test the feasibility of using Thematic Mapper satellite data to detect wetlands, map wetlands, or update existing wetlands maps. None of these tests has provided any hope that present satellite configurations can provide the needed data for classification detail and wetness determinations within desired accuracy requirements of the National Wetlands Inventory Project and its State and Federal cooperators.



## Organizational Structure of the National Wetland Inventory Project

The Fish and Wildlife employs a small staff of biologists assembled into two basic groups; National Wetlands Inventory central control group and regional wetland coordinators. The NWI project leader works out of the Washington, D.C., office and coordinates the budget, annual work plans, and strategic planning.

The NWI Central Control Group in St. Petersburg, Florida, is the focal point for all operational activities of the NWI. This group acquires all materials necessary for performing an inventory, provides technical assistance and work materials to the regional coordinators, and produces the wetlands maps. A private service support contractor is responsible for map production, and provides needed personnel (about 100 technicians and professionals).

Regional wetland coordinators at FWS's seven Regional Offices are responsible for the inventory of wetlands within their regions and ensuring that all NWI products meet regional needs. They manage contracts for wetland photointerpretation, coordinate interagency review of draft maps, secure cooperative funding from other agencies, produce regional wetland reports, and disseminate NWI products. Their addresses, phone numbers, and areas of responsibility are listed in the Appendix.

Photointerpretation and fieldwork are performed by contractors hired by FWS. These contractors photointerpret wetlands with stereoscopes. In addition, they review soil maps, conduct field checks, and examine existing information on an area's wetlands to ensure accurate identification of wetlands.

### Operational Phase

The operational phase of the NWI, initiated on 1 October 1979, involves two main efforts: wetlands mapping and wetlands status and trends analysis. In addition to the wetlands maps and trends reports produced through statistical analysis, NWI produces other products that complement the mapping effort, including a preliminary list of hydric soils, the *National List of Plant Species that Occur in Wetlands* (Reed 1988), numerous wetland

reports, and textual and geographic computerized data bases.

### *National Wetlands Inventory Maps*

The primary product of the NWI is large-scale (1:24,000) maps that show the location, shape, and characteristics of wetlands and deepwater habitats on U.S. Geological Survey base maps. These detailed maps are excellent for site-specific project evaluation.

To produce final National Wetlands Inventory maps, seven major steps must be completed: (1) preliminary field investigations, (2) interpretation of high-altitude photographs, (3) review of existing wetland information, (4) regional and national consistency quality control of interpreted photos, (5) draft map production, (6) interagency review of draft maps, and (7) final map production. Swartwout (1982) and Crowley et al. (1988) evaluated NWI maps and determined that the maps were 95 and 91% accurate, respectively. Accuracy determinations included errors of omission as well as commission. This high accuracy was achieved because of the NWI technique, which involves a combination of field studies, photointerpretation, use of existing information, and interagency review of draft maps.

### *Wetland Status and Trends Reports*

The national wetlands status and trends analysis study originated from the need for national estimates on the present extent of our Nation's wetland resources in the lower 48 States and on corresponding losses and gains over the past 20 years. A statistical survey of U.S. wetlands in the mid-1950's and mid-1970's was conducted through conventional air photointerpretation techniques. The status of wetlands in the mid-50's and mid-70's was determined, and estimates of losses and gains during that interval were computed. The national sampling grid consists of a stratified random sample of 3,635 4-square-mile plots distributed within strata being formed by State boundaries, and the 35 physical subdivisions described by Hammond (1970). Additional strata were added to include (1) a coastal zone stratum encompassing those wetlands near coastal influence, and (2) the area immediately adjacent to the Great Lakes. Sample units were allocated to strata in proportion to the expected amount of wetland and deepwater habitat acreage estimated as determined by the earlier work of Shaw and Fredine (1956). The

results of this study were published in four major reports by Frayer et al. (1983); Tiner (1984); U.S. Congress, Office of Technology Assessment (1984); and Goldstein (1988).

About 215 million acres of wetlands existed in the conterminous United States (i.e., lower 48 States) at the time of the Nation's settlement. In the mid-1970's, only 99 million acres, or 46% of the original wetland acreage remained; these 99 million acres included 93.7 million acres of palustrine wetlands and 5.2 million acres of estuarine wetlands. Wetlands now cover about 5% of the land surface of the lower 48 States.

Between the mid-1950's and mid-1970's, about 11 million acres of wetlands were lost, while 2 million acres of new wetlands were created. Thus, in that 20-year interval alone, there was a net loss of 9 million acres of wetlands or an average annual net loss of 458,000 acres. This annual loss equals an area about half the size of Rhode Island. Agricultural development was responsible for 87% of recent national wetland losses, urban development caused 8%, and other development caused 5%.

The most extensive wetland losses were in Arkansas, Florida, Louisiana, Mississippi, Nebraska, North Carolina, North Dakota, South Dakota, and Texas. Greatest losses of forested wetlands were in the lower Mississippi Valley, with the conversion of bottomland hardwood forests to farmland. Shrub wetlands were hardest hit in North Carolina, where pocosins in wetlands were converted to cropland or pine plantations, or mined for peat. Inland marsh drainage for agriculture was most significant in the Prairie Pothole region of the Dakotas and Minnesota, Nebraska's Sandhills and the Rainwater Basin, and Florida's Everglades. Between the mid-1950's and mid-1970's, estuarine wetland losses were heaviest in the Gulf States of Louisiana, Florida, and Texas. Most of Louisiana's coastal marsh losses were attributed to submergence by coastal waters. In other areas, urban development was the major direct human-induced cause of coastal wetland loss. Dredge and fill for residential development in coastal areas was most significant in California, Florida, New Jersey, New York, and Texas.

### *Hydric Soils List (Wetland Soils)*

Hydric soils are defined by soil saturation for a significant period or by frequent flooding for long periods during the growing season. To clarify the meaning of "hydric soils," the NWI, in cooperation

with the Soil Conservation Service, developed the first list of the Nation's hydric soils. Since then, the Soil Conservation Service has chaired the Interagency National Technical Committee for Hydric Soils. The *National List of Hydric Soils of the United States, December 1987* (U.S. Department of Agriculture 1987) is available from the Soil Conservation Service. This soils list is useful for making wetland determinations in the field, or in the office through use of soil survey maps.

### *List of Plants that Occur in Wetlands*

The U.S. Fish and Wildlife Service published the *National List of Plants Species that Occur in Wetlands: 1988 National Summary* (Reed 1988). The plants in this list<sup>1</sup> are divided into four indicator categories based on the plants' frequency of occurrence in wetlands: (1) obligate—always found in wetlands (greater than 99% of the time); (2) facultative wet—usually found in wetlands (66–99% of the time); (3) facultative—sometimes found in wetlands (33–66% of the time); and (4) facultative upland—seldom found in wetlands (less than 33% of the time).

The wetland plant list data base is a listing of plants associated with wetlands, as defined by the U.S. Fish and Wildlife Service's wetland definition and classification system (Cowardin et al. 1979). It lists scientific and common names of plants, distribution, and regional wetland indicator status of almost 6,700 plant species. It can be accessed by plant name, region, State, and wetland indicator status. The data base is updated as additional information is received.

The wetland plant species data base<sup>2</sup> has two parts. The first, PLANTS, contains detailed

<sup>1</sup> This list is available from the Superintendent of Documents, U.S. Government Printing Office, Washington, D.C., 20402, phone (202)783-3235, Stock Number 024-010-00682-0; cost is \$12.00. Thirteen regional subdivisions of the list are available from the National Technical Information Service, 5285 Port Royal Rd., Springfield, Va. 22161, phone (703)487-4650. State lists are also available.

<sup>2</sup> Regional subdivisions of the wetland plant list data base are available on floppy disks in ASCII format for use on IBM XT/AT-compatible machines running the equivalent of MS-DOS 2.0 or higher. Contact the Office of Conference Services, Colorado State University, Fort Collins, Colo. 80523, phone (303)491-7767. State subdivisions of the wetland plant list data base are available in a wide variety of formats on floppy disks for use on IBM PC XT/AT-compatible machines running the equivalent of MS-DOS 2.0 or higher. Contact BIO-DATA, INC., P.O. Box 280605, 331 Wright Street, 7-107, Lakewood, Colo. 80228, phone (303)987-2557.

taxonomic, distributional, and habitat information on more than 6,200 wetland plants found in the United States and its territories. The second part, BOOKS, contains bibliographic citations for more than 280 sources such as floras, checklists, and botanical manuals used to compile PLANTS.

### *Wetland Reports*

Two basic wetland reports are developed by the NWI; map reports and State wetland reports. The map reports briefly outline NWI procedures and findings (e.g., list of wetland plant communities, photointerpretation problems). Map reports are available for all mapped areas. By contrast, the State wetland report is a comprehensive publication on the results of the NWI in a given State. It is prepared on completion of the wetlands inventory in a State. The State report includes wetland statistics and detailed discussions of NWI techniques, wetland plant communities, hydric soils, and wetland values. To date, State reports have been produced for Delaware and New Jersey. NWI expects to prepare reports for Connecticut, Florida, Hawaii, Pennsylvania, Rhode Island, and Washington when statistics become available.

### *The Wetlands Values Citation Data Base*

The wetlands values citation data base<sup>3</sup> is a bibliographic listing of more than 12,000 scientific articles about the functions and values of wetlands. Field names include author, year, sequence, title source, and subject.

## **Status of Mapping**

The National Wetlands Inventory has produced wetland maps for 68% of the lower 48 States and 21% of Alaska (Figs. 1 and 2). Mapping priorities are based principally on the needs of FWS and other Federal and State agencies. Priorities include the coastal zone (including the coastline of the Great Lakes), prairie wetlands, playa lakes, floodplains of

major rivers, and other areas that reflect the goals of the North American Waterfowl Plan.

The actual priority of mapping depends on the availability of funds and the existence of high-quality aerial photography. Obtaining acceptable photographs for the Prairie Pothole region has been particularly difficult because of the need to capture optimum water conditions. Consequently, the NWI has established a special agreement with NASA to obtain this photography. The NWI produces wetland maps at a rate of 5% per year in the lower 48 States and at 2% annually in Alaska. This is the equivalent of 3,200 1:24,000-scale quads a year in the lower 48 States and 60 1:63,360-scale quads in Alaska.

### *Map Dissemination*

More than one million copies of draft and final wetlands maps have been distributed by the NWI.<sup>4</sup> This figure does not include the secondary distribution made through the State-run distribution centers in Alabama, Connecticut, Delaware, Guam, Hawaii, Illinois, Kentucky, Louisiana, Maine, Maryland, Massachusetts, Mississippi, Nebraska, New Hampshire, New Jersey, New York, North Carolina, Ohio, Pennsylvania, Rhode Island, South Carolina, Texas, Vermont, Washington, West Virginia, and Wyoming.

### *National Wetlands Inventory Digital Data Base*





The NWI is constructing a georeferenced wetland data base<sup>5</sup> with geographic information system (GIS) technologies. Digitizing is done in arc-node format, with attributes assigned to the left, center, and right sides of each arc. Wetland attributes are coded according to Cowardin et al. (1979). As digitization occurs, points are converted to latitude/longitude coordinates. As a result, all map data are stored in a common, ground-based geographic reference system.

<sup>3</sup> The information is available on floppy disks in ASCII format for use on IBM PC/XT/AT-compatible machines running the equivalent of MS-DOS 2.0 or higher. Contact the Office of Conference Services, Colorado State University, Fort Collins, Colo. 80523, phone (303)491-7767.

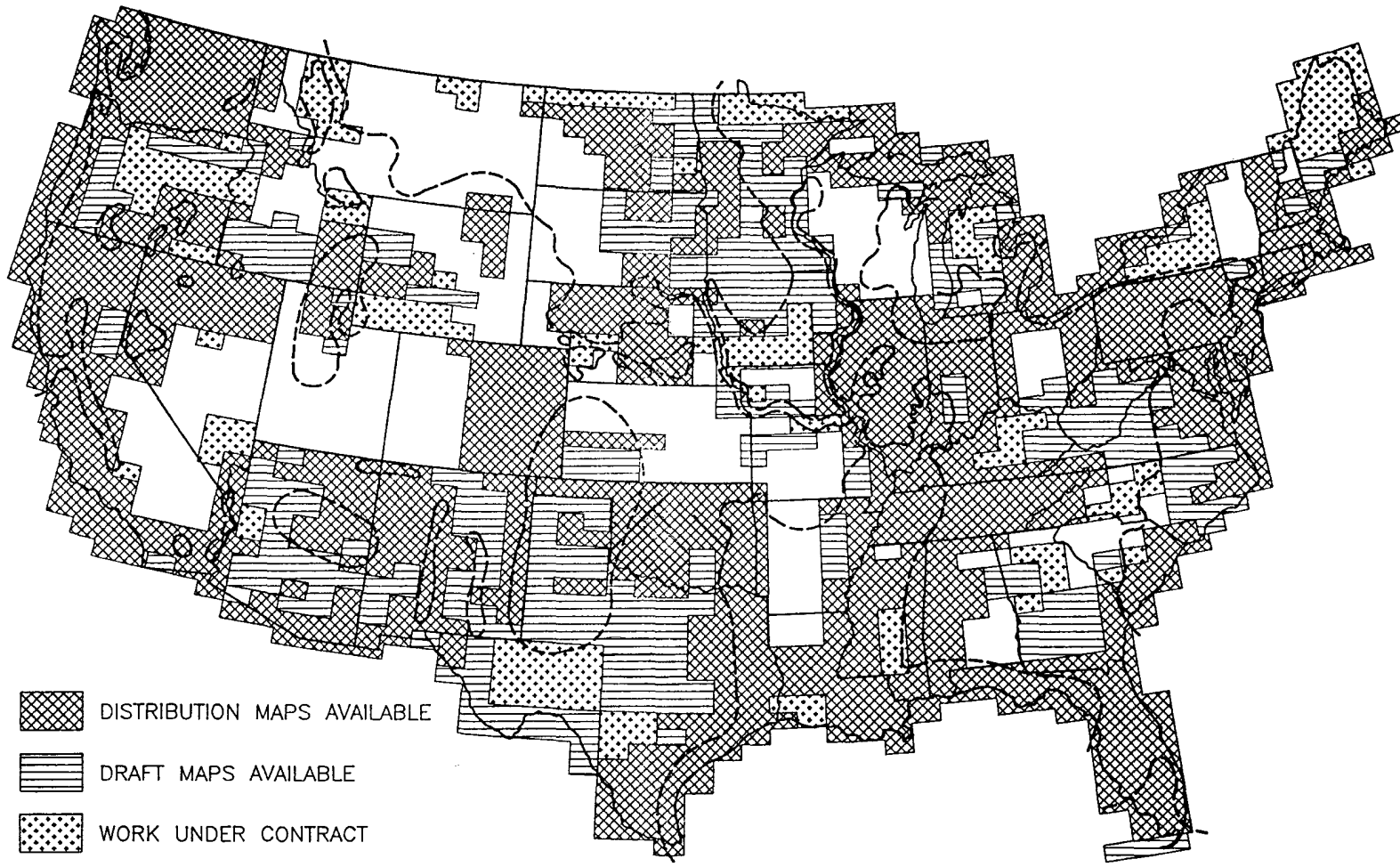
<sup>4</sup> Information on the availability of the National Wetlands Inventory maps and ordering information may be obtained by calling (toll-free) 1-800-USA-MAPS.

<sup>5</sup> Copies of data-base files can be purchased at cost from the NWI Office in St. Petersburg, Florida, phone (813)893-3873. The data are provided on magnetic tape in MOSS export, DLG3 optional, and ELAS, IGES, GRASS formats. Other products available at cost include acreage statistics by quad, county, or study area, and color-coded wetland maps.



-  DISTRIBUTION MAPS AVAILABLE
-  DRAFT MAPS AVAILABLE
-  WORK UNDER CONTRACT
-  WATERFOWL AREAS OF CONCERN

TELEPHONE 1-800-USA-MAPS FOR MAP INFORMATION JANUARY 1, 1990

Fig. 1. Status of the National Wetlands Inventory in relation to waterfowl habitat areas.

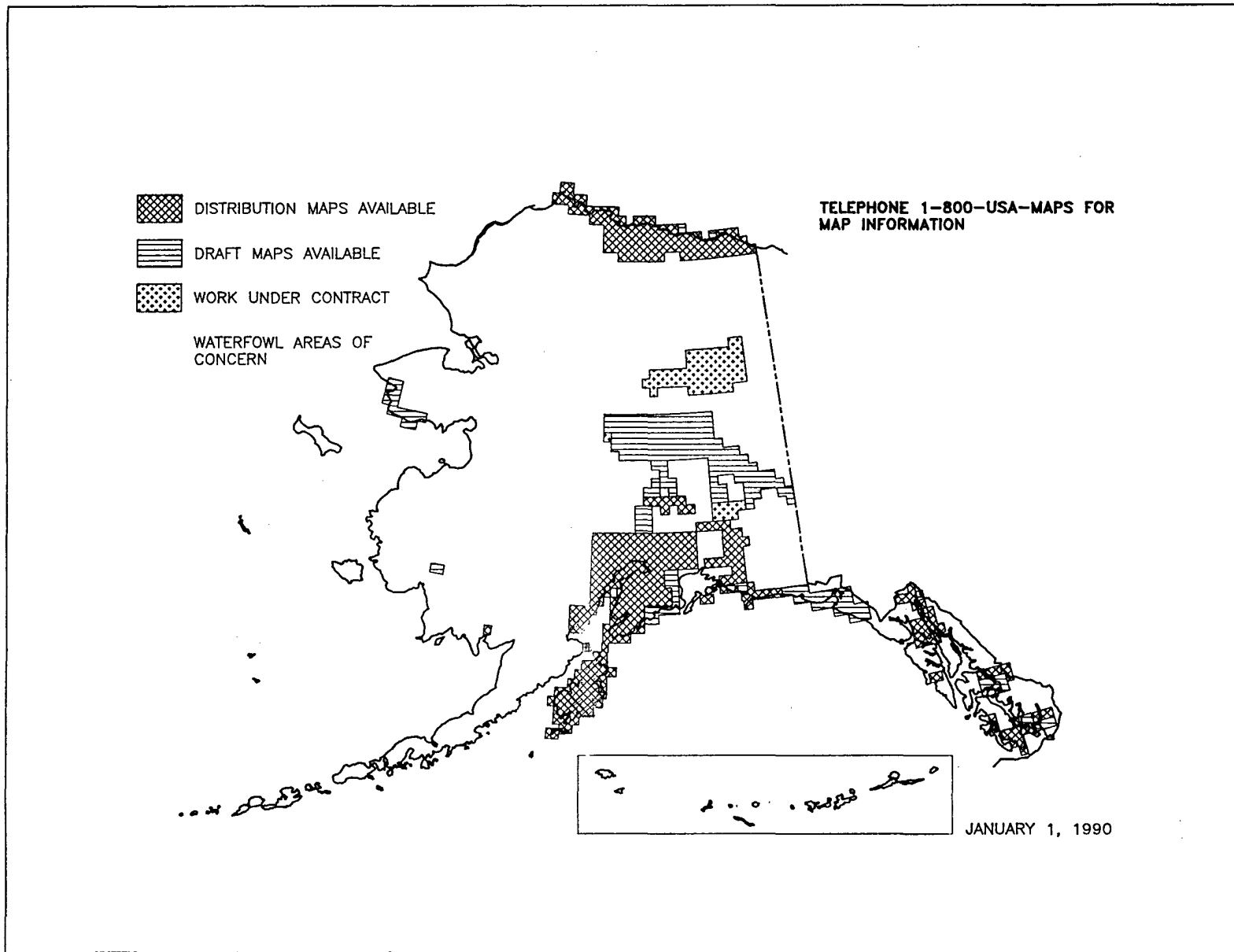
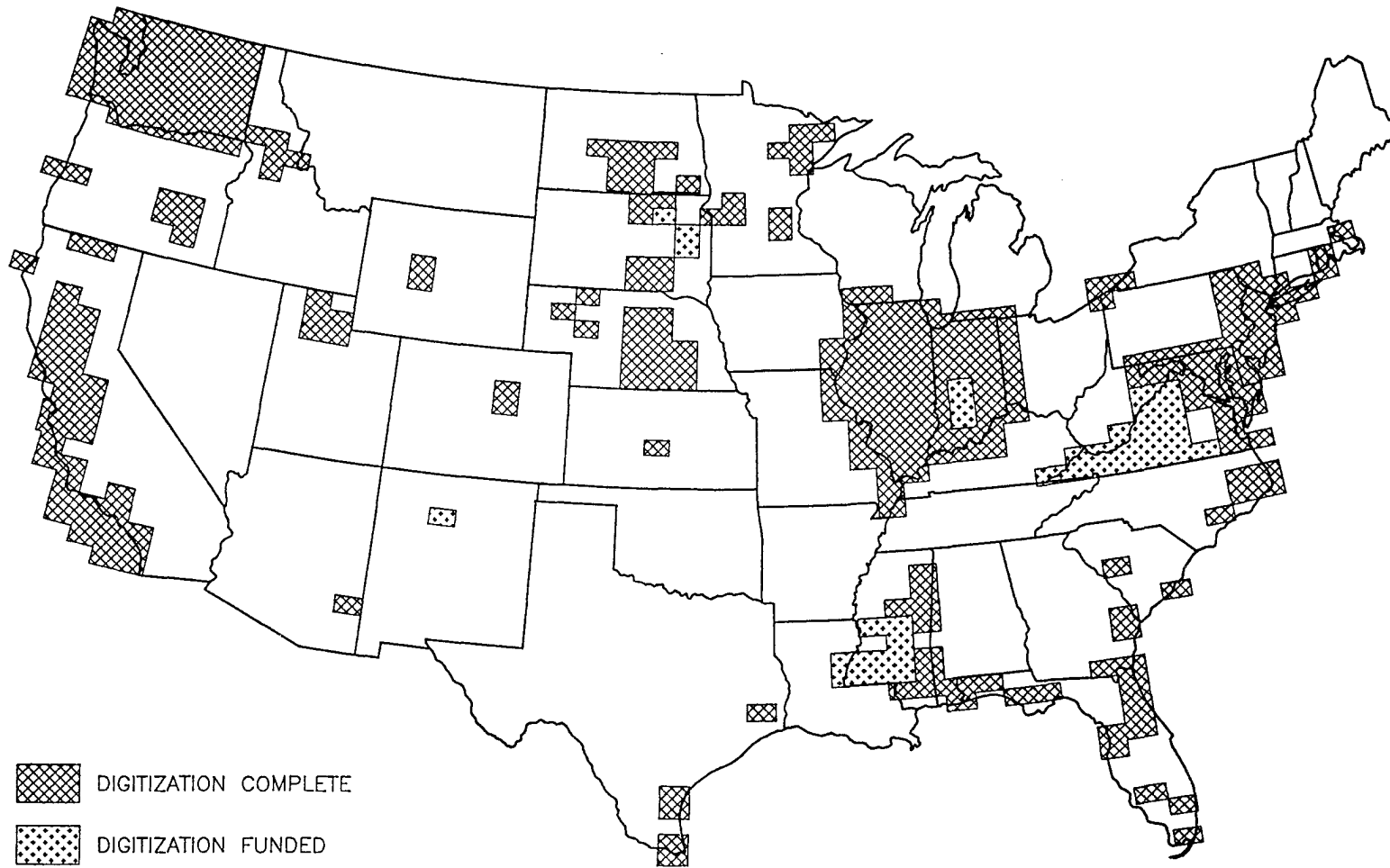



Fig. 2. Status of the National Wetlands Inventory in Alaska in relation to waterfowl habitat areas.



 DIGITIZATION COMPLETE  
 DIGITIZATION FUNDED

TELEPHONE 1-800-USA-MAPS FOR MAP INFORMATION JANUARY 1, 1990

Fig. 3. Status of National Wetlands Inventory digital data.

To date, more than 5,700 NWI maps, representing 10.5% of the continental United States, have been digitized (Fig. 3). Statewide data bases have been built for Delaware, Illinois, Maryland, New Jersey, and Washington, and are in progress for Indiana and Virginia. NWI digital data also are available for portions of 20 other States.

These digital data are being used for applications such as resource management planning, impact assessment, wetland trend analysis, and information retrieval.

### *Map and Digital Data: Users and Uses*

The number of map users has grown steadily since the maps were first introduced. Requests are common from individuals, private organizations, industry, consulting firms, developers, agencies from all levels of government, and educational and research groups. User surveys have documented over 100 different uses of the wetland maps. Resource managers in FWS and in the States are provided with information on wetland location and type, which is essential for effective habitat management and acquisition of important wetland areas. These areas are needed to perpetuate waterfowl populations and other migratory bird populations as called for in the North American Waterfowl Management Plan.

The Department of Agriculture uses the maps as a major tool in the identification of wetlands for the administration of the "Swampbuster" provisions of the 1985 Food Security Act. Copies of all draft and final maps are sent to the Soil Conservation Service's county offices.

Regulatory agencies use the maps to help in advanced identification, determining wetland values, and mitigation requirements. Private sector planners use the maps to determine the location and nature of wetlands to aid in framing alternative plans to meet regulatory requirements. These maps are instrumental in preventing problems that arise because the maps eliminate confusion over whether an area is a wetland. They are also instrumental because they provide facts that allow sound business decisions to be made quickly, accurately, and efficiently.

### **Future Activities**

Future activities of the FWS include updating the report entitled *Status and Trends of Wetlands and Deepwater Habitats in the Conterminous*

*United States, 1950's to 1970's* by 30 September 1990, and thereafter at 10-year intervals. Other activities will produce National Wetlands Inventory maps for the remainder of the contiguous United States by 1988 and, as soon as practicable thereafter for Alaska and noncontiguous portions of the United States.

The top priority activity for funding increase is to intensify the national sampling grid used to determine national wetlands status and trends. This would allow accurate regional wetland acreage change and loss information to be developed for the Atlantic and Gulf coasts, Great Lakes watershed, lower Mississippi River alluvial plain, and lower Prairie Pothole region in 1992, 1993, and 1994, respectively. In future years, this funding increase will allow the development of accurate regional data for the southeastern United States and the Playa Lakes region in the Southwest. Regional intensifications of the wetlands inventory will support other resource efforts underway within the States and the Department of the Interior, and will fill a significant wetland information data gap identified by the National Wetlands Policy Forum. The intensifications will provide the information needed to develop or alter management programs to ensure sound stewardship and protection. The coastal intensification will provide the wetlands data needed to support the Secretarial Initiative on Global Change.

A second priority will be to operate the current wetlands status and trends effort in a continuous mode, with reporting done at 5-year intervals, and with interim estimates as necessary. A continuous wetland trends inventory would involve updating a percentage of the plots each year; for example, 10% of the plots would be updated each year on a 10-year cycle. Advantages gained from a continuous trend process include better coordination with resource priorities, better responsiveness to State and regional needs, more accurate and current assessment of wetland resources, and better use of existing data.

### **Acknowledgments**

I thank the staff and contract personnel of the National Wetlands Inventory for their work over the last decade. The accomplishments presented in this paper could not have been achieved without the financial support of many Federal, State, and local cooperators. The accuracy of the maps, in

good part, is the result of the voluntary map review by many Federal, State, local, and private sector agencies and organizations, as well as persons such as G. Fore of Texas. I thank C. Lee for typing the manuscript and M. Bates for her review.

## References

- Cowardin, L. M., V. Carter, F. C. Golet, and E. T. LaRoe. 1979. Classification of wetlands and deepwater habitats of the United States. U.S. Fish Wildl. Serv., FWS/OBS-79/31. 130 pp.
- Crowley, S., C. O'Brien, and S. Shea. 1988. Results of the wetland study and the 1988 draft wetland rules. Report by the Agency of Natural Resources Divisions of Water Quality, Waterbury, Vt. 33 pp.
- Fraye, W. E., T. J. Monahan, D. C. Bowden, and F. A. Graybill. 1983. Status and trends of wetlands and deepwater habitats in the conterminous United States, 1950's to 1970's. Department of Forest and Wood Sciences, Colorado State University, Fort Collins. 32 pp.
- Goldstein, J. H. 1988. The impact of Federal programs on wetlands. Vol. I. The lower Mississippi alluvial plain and the Prairie Pothole region. Report to Congress by the Secretary of the Interior. 114 pp.
- Hammond, E. H. 1970. Physical subdivisions of the United States. Pages 61-64 in National atlas of the United States. U.S. Geological Survey, Washington, D.C.
- Reed, P. B., Jr. 1988. National list of plant species that occur in wetlands: national summary. U.S. Fish Wildl. Serv., Biol. Rep. 88(24). 244 pp.
- Shaw, S. P., and C. G. Fredine. 1956. Wetlands of the United States. U.S. Fish Wildl. Serv., Circ. 39. 67 pp.
- Swartwout, D. J. 1982. An evaluation of National Wetlands Inventory in Massachusetts. M.S. thesis, University of Massachusetts, Amherst. 123 pp.
- Tiner, R. W., Jr. 1984. Wetlands of the United States: current status and recent trends. U.S. Fish and Wildlife Service, National Wetlands Inventory, Washington, D.C. 59 pp.
- U.S. Congress, Office of Technology Assessment. 1984. Wetlands: their use and regulation. OTA-0-026. 208 pp.
- U.S. Department of Agriculture, Soil Conservation Service. 1987. Hydric soils of the United States. In cooperation with the National Technical Committee for Hydric Soils. U.S. Department of Agriculture, Soil Conservation Service, Washington, D.C.
- U.S. Department of the Interior. 1976. Existing State and local wetlands surveys 1965-75. U.S. Fish and Wildlife Service, Washington, D.C. 453 pp.



## Appendix. Regional Wetland Coordinators

Region	Geographic Area	Regional Wetland Coordinator
1	California, Guam, Hawaii, Idaho, Nevada, Oregon, Samoa, Washington	Regional Wetland Coordinator U.S. Fish and Wildlife Service Eastside Federal Complex 911 N.E. 11th Avenue Portland, Oregon 97232-4181 Comm: (503) 281-6154 FTS: 429-6154
2	Arizona, New Mexico, Oklahoma, Texas	Regional Wetland Coordinator U.S. Fish and Wildlife Service 500 Gold Avenue, S.W., Room 4012 Albuquerque, New Mexico 87103 Comm: (505) 766-2914 FTS: 474-2914
3	Illinois, Indiana, Iowa, Michigan, Minnesota, Missouri, Ohio, Wisconsin	Regional Wetland Coordinator U.S. Fish and Wildlife Service 401 East 80th Street Bloomington, Minnesota 55425-1600 Comm: (612) 725-3417 FTS: 725-3417
4	Alabama, Arkansas, Florida, Georgia, Kentucky, Louisiana, Mississippi, North Carolina, South Carolina, Tennessee, Virgin Islands	Regional Wetland Coordinator U.S. Fish and Wildlife Service R.B. Russell Federal Building 75 Spring Street, S.W., Suite 1276 Atlanta, Georgia 30303 Comm: (404) 331-6343 FTS: 841-6343
5	Connecticut, Delaware, Maine, Maryland, Massachusetts, New Hampshire, New Jersey, New York, Pennsylvania, Rhode Island, Vermont, Virginia, West Virginia	Regional Wetland Coordinator U.S. Fish and Wildlife Service One Gateway Center, Suite 700 Newton Corner, Massachusetts 02158 Comm: (617) 965-5100 FTS: 829-9379
6	Colorado, Kansas, Montana, Nebraska, North Dakota, South Dakota, Utah, Wyoming	Regional Wetland Coordinator U.S. Fish and Wildlife Service P.O. Box 25486 Denver Federal Center Denver, Colorado 80225 Comm: (303) 236-2985 FTS: 776-2985
7	Alaska	Regional Wetland Coordinator U.S. Fish and Wildlife Service 1011 East Tudor Road Anchorage, Alaska 99503 Comm: (907) 786-3471 FTS: 869-3471

# Coastal Barrier Resources System Mapping Process

by

Mary C. Watzin<sup>1</sup>

*U.S. Fish and Wildlife Service  
National Wetlands Research Center  
1010 Gause Boulevard  
Slidell, Louisiana 70458*

**ABSTRACT.**—The Coastal Barrier Resources Act of 1982 (PL. 97-348) established the Coastal Barrier Resources System (system), a 452,834-acre system of undeveloped, unprotected coastal barriers along 666 shoreline miles of the Atlantic Ocean and Gulf of Mexico coasts. Within the 186 units of the Coastal Barrier Resources System, most Federal expenditures that encourage development are prohibited. Section 10 of the act directed the Department of the Interior (DOI) to conduct a study and prepare a report to Congress on the Coastal Barrier Resources System. The report, delivered to Congress in December 1988, recommended additions to, or deletions from, the Coastal Barrier Resources System, and listed modifications to the boundaries of system units. The DOI's recommendations, if passed by Congress, would add about 790,884 acres and 423 miles of shoreline to the Coastal Barrier Resources System. The coastal barriers included in the Coastal Barrier Resources System by Congress in 1982 were designated based on definitions and delineation criteria developed by the DOI in 1981-82. The criteria used by the DOI to delineate barriers included in the 1988 recommendations to Congress differed from those used in 1981 in several respects, reflecting advances in the scientific understanding of coastal barriers, and the functional requirements of a good definition. I outline the mapping criteria used in 1981-82 and in 1984-87 during the Section 10 study. I also discuss some of the problems encountered in consistently identifying and delineating features across a heterogeneous national coastline, and I comment on future reinventories of coastal barriers.

## Background on the Coastal Barrier Resources Act and the Section 10 Study

The Coastal Barrier Resources Act (CBRA or act) of 1982 (P.L. 97-348) established the Coastal Barrier Resources System (CBRS or system), a 452,834-acre system of undeveloped, unprotected coastal barriers along 666 shoreline miles of the Atlantic Ocean and Gulf of Mexico coasts. Within the 186 units of the CBRS, most

Federal expenditures that encourage development are prohibited.

The CBRA was the end result of several years of study by Congress and the Department of the Interior (DOI) of Federal programs and their effects on the development of coastal barriers. In 1977, the DOI initiated studies to assess options for modifying about 40 Federal programs that affect coastal barriers, including the National Flood Insurance Program. The results of these studies were released in a draft Environmental Impact Statement in January 1980. Congressional action followed in 1981 with the enactment of Section 341 of the Omnibus Budget Reconciliation Act (OBRA).

Section 341 of OBRA amended the National Flood Insurance Act of 1968 to prohibit the issuance of new Federal flood insurance policies after

<sup>1</sup> Present address: Vermont Cooperative Fish and Wildlife Research Unit, School of Natural Resources, Aiken Center, University of Vermont, Burlington, Vt. 05405

1 October 1983 for any new construction or substantial improvement of structures on undeveloped coastal barriers. The OBRA directed the DOI to (1) designate coastal barriers based on a definition provided in the OBRA, and (2) report to Congress with recommendations relating to the term "coastal barrier." On 13 August 1982, the DOI submitted a report to Congress endorsing the general definitions and delineation criteria for coastal barriers contained in the OBRA, and designating 188 coastal barriers that met those criteria. After the DOI delivered its report to Congress, but before final OBRA implementation, Congress enacted the Coastal Barrier Resources Act.

In addition to a ban on Federal flood insurance, the act also prohibited Federal assistance for a wide range of other programs that encourage development of coastal barriers, such as U.S. Army Corps of Engineers structural development projects and cost-sharing programs for the construction of roads, bridges, water supply systems, and sewers. Section 6 of the act does allow certain Federal activities such as the maintenance of shipping channels, essential military activities, emergency disaster relief, research, and recreational projects.

The purposes of the CBRA are to minimize the loss of human life, reduce damage to fish and wildlife habitat and other valuable natural resources of coastal barriers, and reduce the wasteful expenditure of Federal revenues. The effect of the act is to place the financial risk associated with development on those who choose to live on, or who invest in, the coastal barriers.

Section 10 of the act directed the DOI to conduct a study and prepare a report to Congress that contained recommendations for additions to, or deletions from, the CBRS, and for modifications to the boundaries of system units. The studies to prepare the Section 10 report to Congress began in late 1983 and culminated in 1988 with a final 22-volume report with 4 appendixes. The study was conducted by a task force representing the U.S. Fish and Wildlife Service (FWS), National Park Service, U.S. Geological Survey (USGS), and other Department of Interior offices, under the direction of the Assistant Secretary for Fish and Wildlife and Parks. The final report includes a description of the CBRS, background information about the coastal barriers and coastal programs of each State or Territory, an assessment of conservation alternatives for the CBRS, and recommendations for specific additions to, or deletions from, the boundaries of the CBRS. The DOI's recommendations, if en-

acted by Congress, would add about 790,884 acres and 423 miles of shoreline to the CBRS.

## Definition and Delineation of Coastal Barriers

Section 3(1)(A) of the Coastal Barrier Resources Act defines a coastal barrier as a depositional feature that "(i) consists of unconsolidated sedimentary materials, (ii) is subject to wave, tidal, and wind energies, and (iii) protects landward aquatic habitats from direct wave attack." This definition is essentially identical to that included in the Omnibus Budget Reconciliation Act in 1981. The definition includes barrier islands, barrier spits, bay barriers, and tombolos.

Although the definition of coastal barriers is based on structural and compositional characteristics and is scientifically sound, it was not sufficient for delineating the boundaries of individual barrier units designated for inclusion in the CBRS. Delineation criteria that were pragmatic, concise, related to features in the ground, and applicable over the full range of coastal barrier variation needed to be developed. The original criteria developed in 1981-82 relied primarily on features that were observable on the ground, maps, and aerial photographs. These were modified somewhat in 1984-87 during the Section 10 study. In the following sections, I discuss the major criteria used for both the 1981-82 and the 1984-87 delineations. Details appear in the report to Congress (U.S. Department of the Interior 1988).

*Minimum size.* Because the CBRA allowed for portions of undeveloped barriers to be included in the CBRS, criteria for minimum size were necessary. The major concern was not to include pieces that were so small that they could not function as natural geological and ecological units. Two criteria were established: the unit must include at least 1/4 mile of shoreline on the ocean side and the unit must extend across the barrier from the beach to the bayside aquatic habitats.

*Developmental status.* The difficulty in distinguishing developed from undeveloped coastal barriers lies in the fact that relatively few coastal barriers are pristine. Many barriers have been visibly altered, and others that may seem undeveloped contain structures such as highways or recreational facilities. The Coastal Barrier Resources Act states only that few artificial structures should be present and that the areas should function

naturally. Hence, determining whether a coastal barrier was developed required the establishment of several thresholds and criteria:

- The unit contains fewer than one roofed and walled building for every 5 acres of fastland (nonwetland). These buildings must be constructed according to Federal, State, or local legal requirements and have a projected ground area exceeding 200 square feet.
- No structures or human activities significantly impede geological and ecological processes (i.e., the area functions naturally).
- For units making up only a portion of a barrier, the boundary line is drawn along the “break” in development.

*Composition.* In 1982, only coastal barriers composed of unconsolidated sand and gravel were included in the CBRS. Although coastal barriers generally consist entirely of unconsolidated sediment composed of sand or gravel, sediments do sometimes include silt, clay, cobbles, or larger rocks, or can be consolidated. Areas can be identified that contain carbonate-cemented deposits (such as the Florida Keys), that consist primarily of silt and clay (such as fringing mangroves and cheniers), or that contain discontinuous outcrops of bedrock or coarse glacial deposits that nevertheless function as coastal barriers. In the Section 10 study, the DOI did not require barriers to be composed only of sandy, unconsolidated sediments, and recommended to Congress that the definition of coastal barriers in Section 3(1)(A) be amended by deleting subparagraph (i) (see previous definition).

*Wind, wave, and tidal energies.* Winds, waves, and tides are the immediate forces that maintain or modify coastal barriers. Criteria were needed to determine whether sufficient wind, wave, and tidal energies were present for a landform to be considered a coastal barrier. Two criteria were developed:

- A linear or curvilinear beach is present. This kind of beach indicates the existence of sufficient physical energy as well as an adequate supply of sediment to satisfy the statutory definition of a barrier. By using this criterion, mud flats, exposed marshes, and other emergent coastal features lacking this linearity are clearly distinguished from barriers.
- A beach ridge or berm is located along the seaward side of the barrier. This criterion

helped distinguish linear sand shoals from true barriers.

*Associated aquatic habitat.* The CBRA defines an “undeveloped coastal barrier” to include all associated aquatic habitats: “adjacent wetlands, marshes, estuaries, inlets, and nearshore waters.” This definition reflects the specific conservation purposes of the CBRA to protect the fish, wildlife, and other natural resources of coastal barriers. All such associated aquatic habitats are inseparable parts of the coastal barrier ecosystem. The original units of the CBRS, however, only include minimum aquatic habitat because the 1982 congressional designations were based on DOI delineations for a prohibition on just the sale of Federal flood insurance as required by the Omnibus Budget Reconciliation Act. Those delineations focused on the undeveloped fastland portion of the barriers where residential development might occur.

Coastal barriers protect the aquatic habitats between the barrier and the mainland. These habitats are critically important for many fish and wildlife species, including most species harvested in the Nation’s commercial fish and shellfish industries. The barrier and its associated habitats are one ecological system, and the health and productivity of the entire system depend on the rational use of all the component parts.

“Associated aquatic habitat” includes all wetlands (e.g., tidal flats, swamps, mangroves, and marshes), lagoons, estuaries, coves between the barrier and the mainland, inlets, the nearshore waters seaward of the sand-sharing system, and, in some tropical areas, the coral reefs associated with the nearshore mangroves. Under normal weather conditions, only aquatic habitats immediately adjacent to coastal barriers are exposed to direct wave attack. Major storms, however, routinely affect the entire landward aquatic habitat. Such habitat survives major storms because coastal barriers receive the brunt of the ocean’s energies. Storm waves break on the barrier beach, leaving a diminished wave to travel into the wetland. At the same time, the wetland stores storm floodwaters, easing the flood pressure on the mainland. In the Section 10 study, the associated aquatic habitat was considered as the entire area subject to diminished wind, wave, and tidal energy during a major storm because of the presence of the coastal barrier. This is a considerably more expanded area than was included in 1981–82.

*Delineation of the landward boundary.* Once an undeveloped coastal barrier and its associated

aquatic habitat were identified, boundary delineation was made in the manner presented next.

1. General case:

The landward boundary is a continuous line that follows the interface between the aquatic habitat and the mainland, as defined on topographic maps or aerial photographs by a change in vegetation.

2. Special conditions:

- a. Open water body greater than 1-mile wide landward of the coastal barrier. The boundary is drawn through the open water about 1 mile landward of the farthest landward extent of wetlands on the protected side of the coastal barrier. If a discernible natural channel, artificial channel, or political boundary exists in the open water about 1 mile landward of the coastal barrier, it is used as the landward boundary. The boundary is drawn along the channel side nearest the coastal barrier.
- b. Continuous wetlands that extend for more than 5 miles landward of the coastal barrier. The boundary is generally drawn through the wetlands along an identifiable natural channel, artificial channel, or political boundary nearest to the 5-mile limit. If such features are lacking, the boundary is drawn through the wetland generally parallel to, and 5 miles landward of, the mean high waterline on the unprotected side of the barrier.

*Delineation on the seaward side.* Each unit contains the entire sand-sharing system, including the beach, shoreface, and offshore bars. In 1982, the seaward boundary of the CBRS units was not delineated. In the Section 10 study, the sand-sharing system of open coast barriers was defined as the 30-foot bathymetric contour. In large coastal embayments, the sand-sharing system is more limited in extent. It was defined as the 20-foot bathymetric contour or a line about 1 mile seaward of the shoreline, whichever is nearer the secondary barrier.

*Secondary barriers.* Secondary barriers are located in large, well-defined bays (e.g., Narragansett Bay, Chesapeake Bay) or in lagoons on the mainland side of coastal barrier systems if a suitable sediment source and sufficient wind, wave, and tidal energies exist. These barriers are maintained primarily by waves generated internally by wind, rather than open ocean waves. Consequently, these barriers are generally smaller and more ephemeral than barriers along the open

ocean coast. Nonetheless, these secondary barriers are formed of unconsolidated sediments just like more oceanic coastal barriers, and more importantly, they also protect critical fish and wildlife habitat and provide substantial protection for the mainland during major storms. In the Section 10 study, secondary barriers were delineated and recommended for addition to the CBRS.

*Geographic scope.* When the Coastal Barrier Resources Act was enacted in 1982, Congress only included barriers on the Atlantic Ocean and Gulf of Mexico coastlines in the CBRS. Although the DOI compiled information about coastal barriers along the Great Lakes, Pacific Coast, Alaska, Hawaii, and American Samoa, it did not include these areas in its final recommendations because the legislative history of the act did not clearly indicate that Congress intended this act to include other coastlines.

Undeveloped and unprotected coastal barriers in the Florida Keys, Puerto Rico, and the Virgin Islands also were not included in the CBRS in 1982. These barriers border the Atlantic Ocean and are subject to the same dynamic forces and developmental pressures as other Atlantic coastal barriers. These coastal barriers fully qualify for addition to the CBRS under the DOI's definitions and were delineated and recommended for inclusion in the system in the Section 10 report to Congress.

*Otherwise-protected coastal barriers.* Congress excluded from CBRS undeveloped coastal barriers that are "included within the boundaries of an area established under Federal, State, or local law, or held by a qualified organization as defined in Section 170(h)(3) of the Internal Revenue Code of 1954, primarily for wildlife refuge, sanctuary, recreational, or natural resource conservation purposes" (hereafter referred to as "otherwise-protected" areas). About one-third of the Atlantic and Gulf coasts fall into this otherwise-protected category. Although these barriers were *not* recommended for addition to the CBRS, they were delineated in the Section 10 study for informational purposes.

*Summary.* All CBRS units were delineated on United States Geological Survey (USGS) 1:24,000-scale topographic quadrangles. Table 1 lists the number of coastal barrier units, shoreline lengths, and acreages included in the CBRS in 1982 and in the final 1988 Section 10 report to Congress. Note that the delineations included in the report to Congress are recommendations only; no changes can be made in the CBRS without congressional action.

Table 1. Summary of the existing Coastal Barrier Resources System (1982) and the Department of the Interior's recommendations to Congress under Section 10 (1988).

	Existing Coastal Barrier Resources System	Coastal Barrier Resources System as recommended
Number of units	186	461
Shoreline length (miles)	666.4	1,088.9
Total acreage	452,834	1,243,678
Fastland acreage	100,934	139,703

## National Wetlands Research Center Mapping of the Coastal Barrier Resources System

The FWS's National Wetlands Research Center (center) has constructed a digital data base of the existing 1982 Coastal Barrier Resources System. This data base was prepared from large-scale (1:12,000 or 1:24,000) color-infrared photographs taken of each Atlantic and Gulf of Mexico coastal

barrier in 1982. From these photographs, maps were prepared delineating fastland (any nonwetland), wetland, open water, developed areas, and selected cultural features (Table 2). These maps were prepared as mylar overlays to 1:24,000-scale USGS topographic quadrangles. The center digitized these maps using a Geographic Information System, and compiled acreage statistics about each CBRS unit. These maps and statistics were intended to serve as baseline data accurately characterizing the CBRS. For details concerning this effort, see Appendix A of the report to Congress (Watzin and Baumann 1988).

The center also studied shoreline change and habitat loss in 19 of the 186 original CBRS units. We compared historic maps with the 1982 maps to quantify changes, and we examined the processes and human activities in and around the barriers to understand the causes of change. We found that in addition to natural changes, all but 1 of the 19 CBRS units had experienced culturally related impacts. Dredging has occurred in or near 17 barrier units, 15 units have shoreline stabilization structures in or near them, and 8 units have dams upstream, reducing the sediment supply to the coast. Most areas that have experienced human influences are eroding (Table 3).

Table 2. Interpretation classes used in a 1982 inventory of the Coastal Barrier Resources System.





Symbol	Legend	Symbol	Legend
<b>Coastal Barrier Interpretation</b>			
FL	Fastland		Structure and associated developed area
WL	Landward wetlands including tidal flats (between fastland and open waters)		Concentrated structures and associated developed areas (number represents total count)
F/W5	Fastland with interior wetland (number represents approximate percentage of the interior wetland—in this example, 5%)	//	Jetties, docks, groins
IOW	Interior open water, water totally enclosed within the barrier fastland or wetland	---	Road
OW	Open water		Study area boundary
<b>Peripheral Land Use Interpretation</b>			
1	Developed (includes residential, industrial, recreational)	5	Open water
2	Undeveloped (includes open space)	---	Road
3	Agriculture		Limit of interpretation
4	Wetland		

Table 3. Summary of human perturbations in the 19 Coastal Barrier Resources System units in the study. (Columns do not total because each unit can experience more than one kind of perturbation.)

Human perturbation	Number of units by condition			Total
	Eroding	Accreting	Stable	
Dredging	15	2	0	17
Structures-updrift	7	1	0	8
Structures-downdrift	5	2	0	7
Structures-within	7	2	0	9
Dams upstream	8	0	0	8
None	1	0	0	1
Number of study units per condition	16	3	0	19

## Periodic Reinventory of the Coastal Barrier Resources System

The CBRA mandates that the CBRS be re-inventoried at least every 5 years to update the official system maps. Section 4(c)(3) states:

The Secretary shall conduct, at least once every five years, a review of the [CBRS] maps . . . and make, in consultation with appropriate officers . . . such minor modifications to the boundaries of system units as are necessary solely to reflect changes that have occurred in the size or location of any system units as a result of natural forces.

The first such review was conducted in 1988. High-altitude infrared photographs (1:65,000 scale) of the CBRS were collected during 1986–88 and visually compared with the 1982 photographs to determine if units had migrated out of their existing boundaries. Only one unit, Cedar Island in Virginia, needed a boundary modification. There is no indication that the DOI intends to collect new photographs for this reinventory in the future.

## Future Needs for the Inventory of Coastal Barriers<sup>1</sup>

The 1982 inventory of the CBRS provides a retrievable data base on the entire existing

Coastal Barrier Resources System. The acreage of fastland in each unit gives a general indication of the developable land in each unit, and the count of structures indicates the development status of those units. At the same time, however, the classification system used in the inventory was so simplistic that the inventory does not provide much useful habitat data for fish and wildlife management, or sufficiently accurate shoreline data (because of discrepancies in classifying tidal flats). Future inventories should correct these problems. The CBRA Section 10 study, however, was a once-only event. There is no mechanism for an ongoing inventory or for change analyses of these coastal habitats.

## References

- U.S. Department of the Interior, Coastal Barriers Study Group. 1988. Report to Congress: Coastal Barrier Resources System. Vols. 1–22. Executive summary. Appendixes A–D. Washington, D.C.
- Watzin, M. C., and R. H. Baumann. 1988. Shoreline change and wetland loss in the Coastal Barrier Resources System: a case study analysis. Appendix A in Report to Congress: Coastal Barrier Resources System. U.S. Department of the Interior, Washington, D.C. 146 pp.

<sup>1</sup> On 16 November 1990, Congress passed the Coastal Barrier Improvement Act of 1990 (P.L. 101-591). This act reauthorizes the CBRA and codifies many of the recommendations in the 1988 report to Congress. The act adds 384 units and 819,666 acres to the CBRS. These additions include 80 new units and about 30,000 acres along the Great Lakes coast.

# National Oceanic and Atmospheric Administration's Habitat Mapping Under the Coastal Ocean Program

by

James P. Thomas

*National Oceanic and Atmospheric Administration's National Marine Fisheries Service  
Office of Research and Environmental Information  
1335 East West Highway  
Silver Spring, Maryland 20910*

and

Randolph L. Ferguson

*National Oceanic and Atmospheric Administration's National Marine Fisheries Service  
Southeast Fisheries Center  
Beaufort Laboratory  
Beaufort, North Carolina 28516*

**ABSTRACT.**—Timely documentation of the location, abundance, and change in coastal wetlands is critical to their conservation and to effective management of marine fisheries. The rapid changes occurring in these valuable wetlands require monitoring on a 1- to 5- year cycle. Therefore, National Oceanic and Atmospheric Administration, within its Coastal Ocean Program, is initiating a cooperative interagency and State and Federal effort to map coastal wetlands and adjacent upland cover and change in the coastal region of the United States every 2 to 5 years, and to annually monitor areas of significant change.

In the first year, fiscal year 1990, the program concentrated on protocol development and prototype studies in Chesapeake Bay and coastal North Carolina. Through a series of workshops and working group meetings, a documented standard protocol will be developed for classifying and mapping habitat location, abundance, and change in the coastal zone of the United States. The Chesapeake Bay prototype study will use Landsat Thematic Mapper imagery and collateral data to map emergent coastal wetlands and adjacent upland cover and change. The coastal North Carolina study will use aerial photography to map and determine change in submerged aquatic vegetation. In outyears, coastal wetlands and adjacent upland cover and change maps will be generated for various coastal regions of the United States, beginning in the Gulf of Mexico. Extant land use and habitat mapping data bases in other Federal and State agencies will be used, where appropriate, to minimize data acquisition cost, supplement ground truth, and assist in verification. This program is cooperative with other Federal and State agencies.

Coastal wetlands are being destroyed by dredge and fill operations, impoundments, toxic pollutants, eutrophication, and, for submergents, excessive turbidity. Coastal wetlands with emergent and submergent vegetation (salt marshes, mangroves, macroalgae, and submerged aquatic vegetation [SAV]) support a majority of marine finfish

and shellfish resources in the coastal United States. Continued loss of these wetlands may lead to a collapse of coastal ecosystems and associated fisheries. Documentation of loss or gain of coastal wetlands is critical to their conservation and to effective management of marine fisheries (Haddad and Ekberg 1987; Haddad and McGarry 1989).



Such information is necessary to respond to President Bush's call for no net loss of wetlands.

Timely quantification of wetland area, location, and rate and cause of loss is needed now (Kean et al. 1988). Management decisions can then be proactive and based on fact, rather than supposition of the effects of coastal development on coastal wetlands and wetland-dependent fisheries (Fig. 1). Current projections for U.S. population growth in the coastal zone suggest accelerating losses of wetlands and adjacent habitats as waste loads and competition for limited space and resources increase (U.S. Congress 1989). Agencies responsible for coastal management must be kept current with regard to the extent and status of wetlands and adjacent uplands. Changes in wetlands are occurring too fast and too pervasively to be monitored once a decade. Therefore, National Oceanic and Atmospheric Administration (NOAA), within its Coastal Ocean Program, is initiating a cooperative inter-agency and State and Federal effort to map coastal wetlands and adjacent upland cover and change in the U.S. coastal region every 2 to 5 years, and to annually monitor areas of significant change.

The 1- to 5-year monitoring cycle will provide feedback to habitat managers on the success or failure of habitat management policies and programs. Frequent feedback to managers will help ensure the continued integrity or recovery of coastal ecosystems and the attendant productivity and health of fish and other living marine resources at minimal cost. In addition, the geographical data base developed under the program will allow both the manager and the researcher to evaluate, and ultimately to predict, cumulative direct and indirect effects of coastal development on wetland habitats and living marine resources.

Remote sensing (from satellites and aircraft) and other techniques will be used to quantify and map coastal wetlands and adjacent uplands. The first cycle will document status and change (retrospectively). The data base, increasing with each subsequent monitoring cycle, will be an invaluable resource for research; evaluation of local, State and Federal wetland management strategies; and construction of predictive models. As such, this program directly supports NOAA's legislated responsibilities in estuarine and marine science,

## Monitoring and Research for Understanding, Prediction and Management

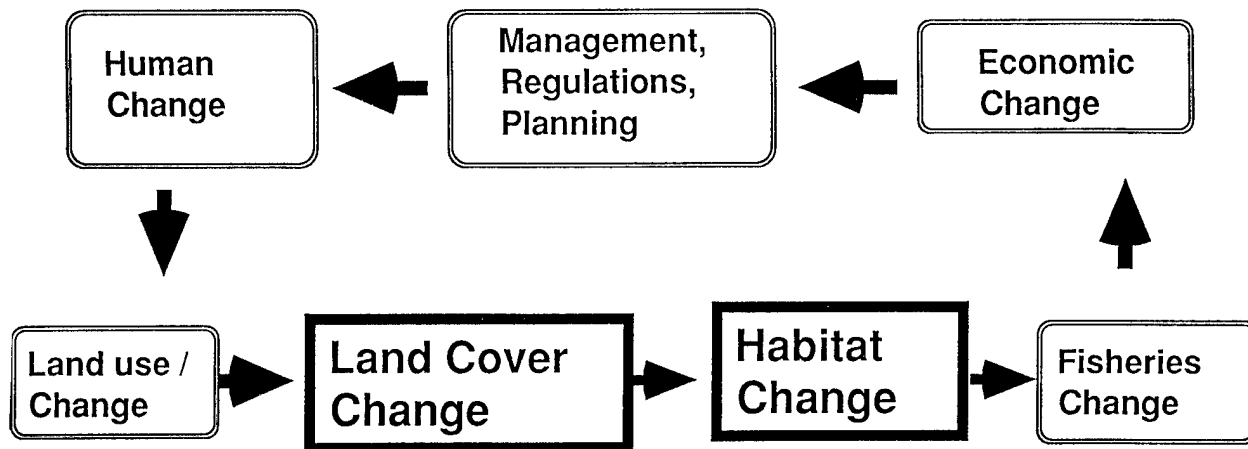

**Fig. 1.** An overview of the NOAA habitat mapping paradigm. Long-term and self-sustaining economic, ecological, and fisheries productivity of the coastal zone requires planning and management of human activity. Habitat classification and change analysis, the initial focus of this program, provide a basis for such planning and management.

monitoring, and management contained in the Fish and Wildlife Coordination Act; the Magnuson Fishery Conservation and Management Act; the Coastal Zone Management Act; the Clean Water Act; the Marine Protection, Research and Sanctuaries Act; the National Environmental Policy Act; and others.

## Approach

Based on a standard protocol, habitat-classified maps will be generated from remotely sensed data, including satellite imagery (Landsat Thematic Mapper [TM], Multispectral Scanner [MSS], or SPOT) and conventional aerial photography. Coastal uplands and wetlands within NOAA's defined "estuarine drainage areas" (NOAA 1985), or modifications of them, will be mapped retrospectively, and monitored every 2 to 5 years (annually in locations of rapid development or significant change). Habitat-classified maps and historical data from other programs, as well as from wetland and estuarine ecologists and fishery biologists, will supplement the surface-level verification component of the program. This approach is intended to build upon and complement ongoing coastal zone sampling and mapping programs carried out by other Federal and State agencies. It will provide timely and synoptic habitat maps, including SAV, and maps of habitat change in the coastal region of the United States. These maps will complement and augment the more geographically comprehensive National Wetlands Inventory maps produced by the U.S. Fish and Wildlife Service (FWS).

MSS, TM, and SPOT imagery have been used successfully to detect all types of wetlands (Haddad and Harris 1985; Lade et al. 1988). Satellite imagery, however, has neither been tested nor applied to mapping wetlands on a regional or national scale. The use of satellite imagery for mapping of wetlands promises a number of advantages over conventional aerial photography including timeliness, synopticity, and reduced costs. While aerial photography is appropriate for construction of habitat-classified maps, satellite imagery is better suited and less costly for rapid, repeated observations over broad regions (Haddad and Harris 1985; Bartlett 1987; Klemas and Hardisky 1987). Although the program will stress the use of satellite imagery, particularly for emergent coastal wetlands and adjacent uplands, aerial photography or a combination of photography and satellite imagery (TM or SPOT) will be used for

mapping SAV and other habitats in selected limited areas, as suggested by Patterson (1986) and Lade et al. (1988). This combination should be the most effective for accomplishing stated objectives at minimal cost.

## Relation to Other Programs

NOAA's habitat mapping effort will work with and use data from other Federal and State agencies during all program phases. It will build on and complement existing coastal habitat mapping programs and provide essential timeliness, synopticity, and frequency of repetitive cycles not currently available. The 1- to 5-year monitoring cycle is critical to NOAA for effective coastal habitat management and research on a local, regional, and national scale.

Extant land use and habitat mapping data bases in other Federal and State agencies will be used, where feasible, to minimize data acquisition cost, supplement ground truth, and assist in verification. Current Federal land use and habitat mapping programs within the U.S. Departments of Interior, Agriculture, Defense, and Commerce, as well as the U.S. Environmental Protection Agency and the National Aeronautics and Space Administration, can provide valuable historical and collateral data for this program (Fig. 2). Portions of habitat mapping programs, ongoing in many States, will be incorporated, where appropriate, into the overall program to reduce redundancy in data acquisition, ground truthing, and field verification. A number of geographically limited TM- and SPOT-based land use and habitat mapping programs are in their early stages (e.g., in Florida, Chesapeake Bay, and Albemarle and Pamlico sounds in North Carolina). It is our intent to encourage such programs through cooperation and joint or supplemental funding to provide comparable and compatible data for mutual use.

## Program Development

NOAA's habitat mapping effort under the Coastal Ocean Program is part of CoastWatch-Land Applications and Estuarine Habitat Studies, both components of the Coastal Ocean Program. As such, the habitat mapping effort will involve (internally) four of NOAA's line organizations: the National Marine Fisheries Service (NMFS); the Office of Oceanic and Atmospheric Research (OAR); the National Ocean Service (NOS); and the

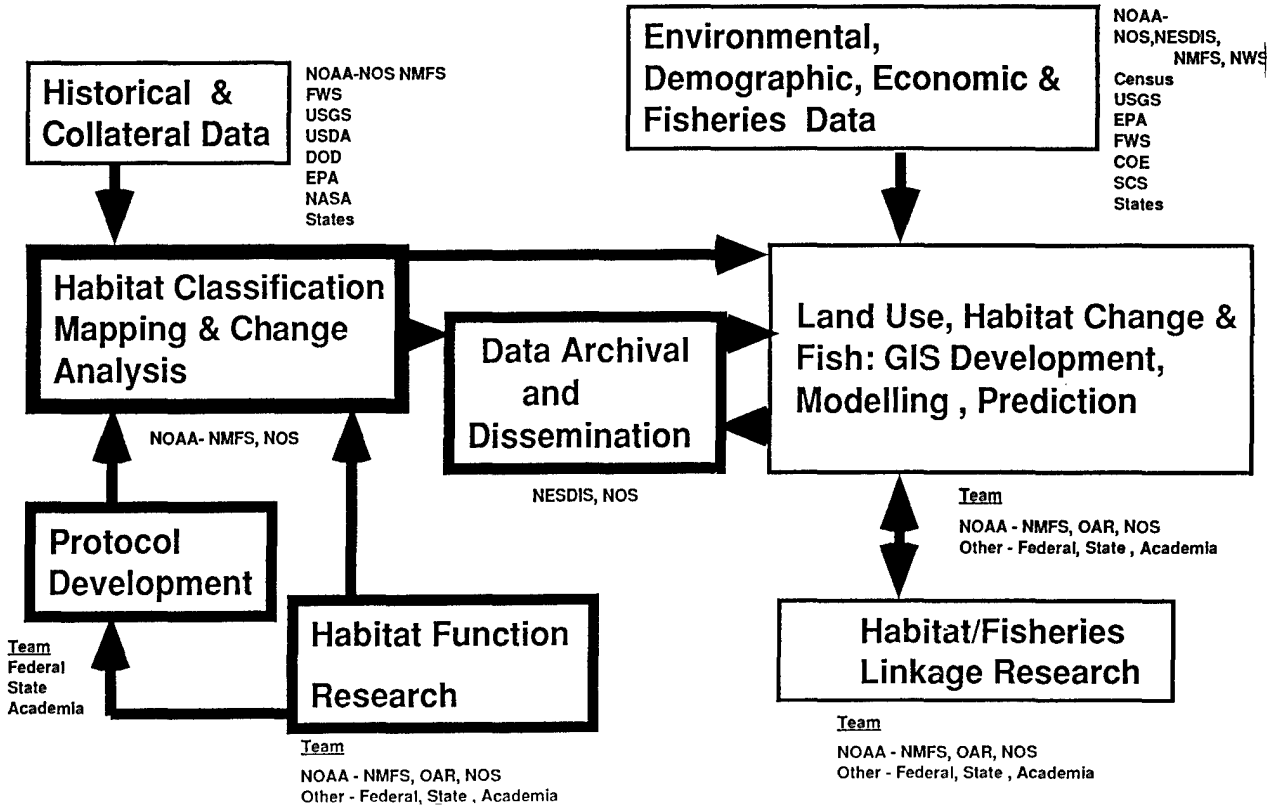

Fig. 2. Programmatic relations of NOAA habitat mapping. Relationships of programmatic elements (emphasized blocks), external data and research needs, and program output to management. The text beside each box indicates the responsible or contributing NOAA and external agencies.

National Environmental Satellite, Data and Information Service (NESDIS). Externally, the effort will involve other Federal and State programs, as previously mentioned. The program will (Fig. 2):

- Establish a national operational protocol. This protocol will provide a uniform basis for classification (i.e., identification of land and habitat cover types) from scene to scene and time to time, thereby allowing comparison of two or more scenes or times. Methods will be selected that will be valid for all regions and will be able to accommodate various types of remote sensing data. The protocol for generating, ground truthing and controlling the quality of the habitat classifications, and the use of historical and collateral data, will be produced through a series of workshops and working group meetings. These meetings will have input from Federal and State agencies producing or using habitat-classified data in the coastal zone, and from professionals with related expertise in remote sensing, geo-

- graphical information systems (GIS), or wetlands in each coastal region of the United States. The published document resulting from these meetings will be the operational protocol to be followed by those generating the classified images within, or cooperatively with, the program.
- Generate, summarize, and distribute habitat-classified data and maps. SAV, emergent coastal wetlands, and adjacent uplands in the United States coastal region will be mapped every 1 to 5 years. The derived products will be applicable to research and management. They will include (1) classified, color-enhanced, geocorrected, and registered images in digital format; (2) hard-copy inventory maps showing habitat classifications with geographic references; and (3) reports describing and tabulating the classification summary by State, county, and hydrologic unit. Maps will be produced at a 1:250,000 scale. However, data for all areas will be retained at full mapping resolution. Thus,

- finer-scale maps (1:24,000) could be produced for selected areas on a cost-recoverable basis.
- Determine, summarize, and map change in areal coverage of each habitat classification. Change in land and habitat cover in the U.S. coastal region will be mapped every 1 to 5 years. To delineate change, pixel by pixel (or equivalent) comparison between scenes from two different times will be done. Such change will be presented as geocorrected and registered maps (1:250,000 scale), with State, county, or hydrological boundaries added. Mapped data for all areas will be retained at full mapping resolution. Thus, finer-scale maps (1:24,000) could be produced for selected areas on a cost-recoverable basis. Additionally, synthesis reports, with text and tables listing change (hectares) for each habitat classification by State, county, and hydrologic unit, will be produced.
  - Remotely determine biomass, productivity, and health status of habitats. This is a research activity to develop methodology and algorithms for image processing that will allow the determination of biomass, productivity, and functional health status of coastal wetlands habitat by remote sensing. The use of such algorithms would allow large areas of wetlands to be surveyed and assessed by satellite or aircraft much more rapidly and easily (Bartlett 1987). By comparing two or more time periods, change in biomass, productivity, or some other as yet undefined observable factor affecting or correlated with spectral reflectance could be used to index functional health. This activity requires ground-based research to relate remotely sensed spectral radiances to biomass, productivity, and, potentially, other factors indicative of the functional health of coastal wetlands.
  - Archive and disseminate data. The digital data base will be archived and disseminated in standard exchange formats as either an optical disc or data tape. NOAA/NESDIS/National Oceanographic Data Center in Washington, D.C., will distribute the data base on a cost-recoverable basis to outside users. Hard-copy maps will be produced, archived, and distributed to outside users by the NOAA/National Ocean Service on a cost-recoverable basis. For those participating in the program, both the digital data and preliminary habitat-classified maps will be provided

through the CoastWatch-Land Applications manager by the group responsible for the processing of the imagery. Such copies will meet the following programmatic needs: quality control, integration and archiving of data, guidance, oversight, and planning.

- Apply habitat classification and change analysis to habitat and fisheries research and management. This program will integrate its products with other spatial data (e.g., demographics, land use, pollution, living marine resources, fisheries, and economics) to generate a data base with a depth and scale previously unavailable to researchers and managers. The data base will be researched by a multidisciplinary team to generate guidance and feedback to habitat management and research personnel and to aid in Federal and State long-range regional planning for habitats and fisheries.

## Discussion of Methods

The spatial and temporal resolution of data and landward and seaward extent of the study area are critical issues for the program. Imagery must resolve and detect changes in coastal wetlands affecting living marine resources at scales suitable to support habitat research and conservation; allow modeling of the link between coastal habitats, coastal ecosystem functioning, and fisheries; and support strategic habitat and fisheries management. Change or loss of coastal wetlands must be documented on time scales necessary to avoid or decrease future losses and to assist in focusing efforts to address the no net loss of wetlands policy for the benefit of living marine resources. Areas of significant change will be mapped more frequently (i.e., every 1 or 2 years), and areas of relatively little change will be mapped less frequently (i.e., every 3 to 5 years).

The landward and seaward extent of the area mapped must include the coastal waters and the adjacent uplands that most directly affect coastal wetland habitats. The NOAA/NOS "estuarine drainage area" (i.e., the land/water component of an entire watershed that most directly affects an estuary) or a modification of that area will be used to define the landward boundary (NOAA 1985). The seaward boundary, beyond the estuary, will be defined by the 10-m isobath in most cases. However, in special circumstances it may need to be defined to 50 m or deeper (Orth et al. 1990).

Compared with aerial photography, digital remote sensing from satellites offers the advantages of synoptic, large-area coverage and frequent repetition (Dobson 1987). Translation of digital spectral data to habitat classifications can be done objectively, rapidly, and reproducibly. The major advantage is that starting with digital input data, remote-sensing specialists, with existing software and equipment, can analyze and communicate far more information about much larger areas faster and at far lower cost than is possible with aerial photography (Haddad and Harris 1985; Bartlett 1987). In fact, the spatial resolution available from TM and SPOT imagery is more precise than that available on many analog habitat maps (Dobson 1987).

Three satellite sensors provide a diverse capability. MSS data provide a spatial resolution (pixel size) of 79 by 56 m. Each scene covers an area on the ground about 180 by 180 km. TM data are collected for pixels of 30 by 30 m, with the same size scene as MSS. SPOT pixels are 20 by 20 m for spectral data (10 by 10 m for panchromatic data) and cover an area on the ground of 60 by 60 km. TM offers a greater spectral range (seven intermittent bands from 0.45 to 12.5  $\mu\text{m}$  than MSS (four contiguous bands from 0.5 to 1.1  $\mu\text{m}$ ) or SPOT (three intermittent bands from 0.5 to 0.89  $\mu\text{m}$ ).

The higher spatial resolution and greater spectral discrimination of TM and the higher spatial resolution of SPOT relative to MSS are valuable characteristics, but they come at a higher cost (full scenes are \$4,900 for geocoded TM, \$3,200 for SPOT Level II, and \$200 for MSS data before 1988). Because they are more data intensive, TM and SPOT images also require greater data processing and storage space per unit of surface area on the ground. Both the MSS and the TM data are capable of providing classified results with 80 to 90% accuracy. TM can provide better discrimination of wetland types, whereas TM and SPOT data are better able to resolve small features. At this point we favor TM or SPOT data for routine imagery of the coastal zone. MSS data, however, have value for retrospective analyses because image acquisition began in 1972, compared with 1982 for TM, and 1986 for SPOT. In areas of special interest, where even greater resolution and discrimination may be needed (e.g., SAV), low-altitude vertical aerial photography will be used.

Clustering analysis techniques will be used to generate the habitat types. Classification methods will be evaluated to determine which best account for latitudinal/longitudinal and tidal effects. Field

verification of the preliminary habitat-classified maps will be accomplished by local, State, and Federal experts and NOAA-supported surveys. The program also will make use of historical and collateral data as much as possible for ground truthing and verification. These collateral data sources potentially will include NOAA-supported field surveys, individual State surveys, the FWS's National Wetlands Inventory, the U.S. Geological Survey's (USGS) Land Use Data Analyses, the county soils and wetlands surveys of the U.S. Soil Conservation Service (SCS), the National High Altitude Aerial Photography Program, and the wetland and coastal surveys of the U.S. Army Corps of Engineers, the U.S. Environmental Protection Agency, and the National Aeronautics and Space Administration.

The program will produce a documented, computerized digital data base of all habitat classifications, including those (e.g., SAV) obtained by aerial photography. These data are to be incorporated into a user-friendly GIS capable of intercomparing habitat-classified data and surface-level data, including biological, demographic, edaphic, economic, fisheries, and physical data, in statistical ways and in graphics.

## Proposed Activities

Proposed activities for NOAA habitat mapping are depicted in Fig. 3.

*Task 1.* During fiscal year (FY) 90–91, through a series of workshops and working group meetings, a documented standard protocol for classifying and mapping habitat location, abundance, and change in the coastal region of the United States is being developed (Fig. 4). A preliminary protocol developed for the Chesapeake Bay area is being evaluated and modified as necessary. Habitat classifications will allow SAV, mangroves, marshes, and other coastal wetlands and adjacent upland habitats, and potentially subdivisions of these habitat types, to be determined. The protocol will be flexible, yet allow comparison of data such that statistical analyses of areal coverage, location, and rate of change can be computed for specified habitat classifications. Flexibility is needed to take into account data of different spatial and temporal scales, and from many regions and sources. Data input will include that from satellite sensors (TM, MSS, and SPOT), aircraft sensors (color, infrared, and black and white photography), and on-foot surveys. Each has different spatial, spectral, and

- A. PROTOCOL DEVELOPMENT
  - Workshops
  - Ches. Bay Wetl, Uplands Prototype
  - N.C. Seagrass Prototype
  - Regional Projects
  
- B/C. LAND COVER / HABITAT CHANGE
  - Gulf of Mexico / Atlantic West Coast
  - Seagrass surveys
    - NC
    - FL
    - TX
  
- D. SUPPORTING RESEARCH
  - Biomass, productivity, health
  
- E. INTEGRATION & MODELING
  - Land, habitat, fish, and economics

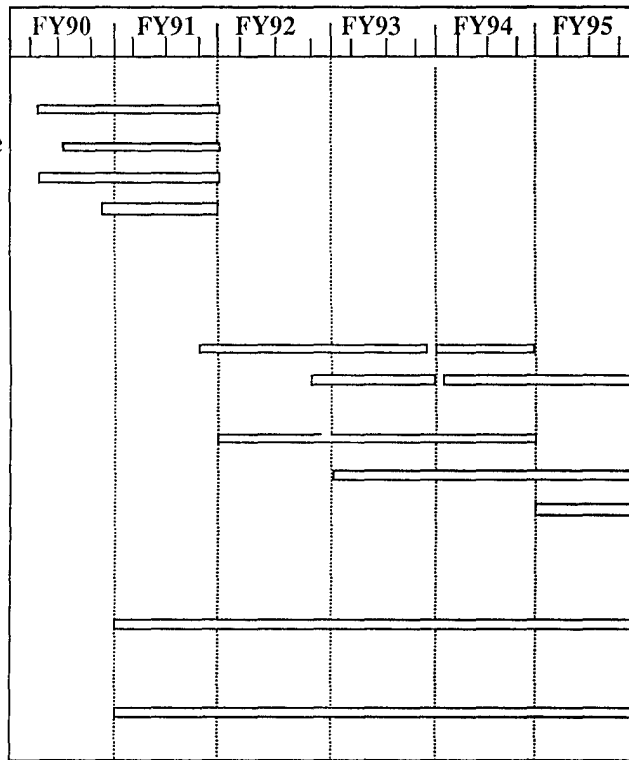

Fig. 3. Activities schedule for NOAA habitat mapping.

temporal resolutions. Likewise, the protocol will allow for use of data from other major sources (e.g., FWS's National Wetlands Inventory, USGS's Land Use Data Analysis, SCS's soil survey maps, the National High Altitude Photography Program, State surveys, and others). The protocol topics will include:

- habitat classifications (e.g., Cowardin et al. [1979] for wetlands, Anderson et al. [1976] for uplands, or some modification of the two);
- selection and surface-level sampling of training sites;
- image selection from satellites, mission authorization for aerial photography, and quality control of images;
- image processing, use of historical and collateral data, photointerpretation and digitization, and change analysis;
- map projection and scale, and other graphic and statistical products; and
- quality control of image acquisition, georeferencing, habitat classification, data processing, digitization, and map projection and scale.

Participants at the workshops and working group meetings include technical experts in the collection, processing, and use of habitat-classification data (e.g., ecologists, fishery biologists, satellite image processors, geographic data-base specialists, modelers, and habitat and fisheries managers).

*Task 2.* In FY90, a prototype effort classifying and merging four TM scenes from two different periods (1984 and 1988/89) for the estuarine drainage area of Chesapeake Bay will be accomplished. The classified, merged scenes will be produced as color-enhanced maps (scale 1:100,000), one for each period. The two periods will be compared pixel by pixel (or equivalent), and a change analysis map (scale 1:100,000) will be produced. Finer-scale maps (1:24,000) covering any portion of the area can be produced for each period or for change analysis on a cost-recoverable basis. Tables will summarize the areal extent (in hectares) of habitat classifications at each period and the changes that occurred from one period to the next. We have access to, and will incorporate into this task, a previous habitat classification of the Chesapeake Bay area for 1978 (Dobson and Bright 1989), and

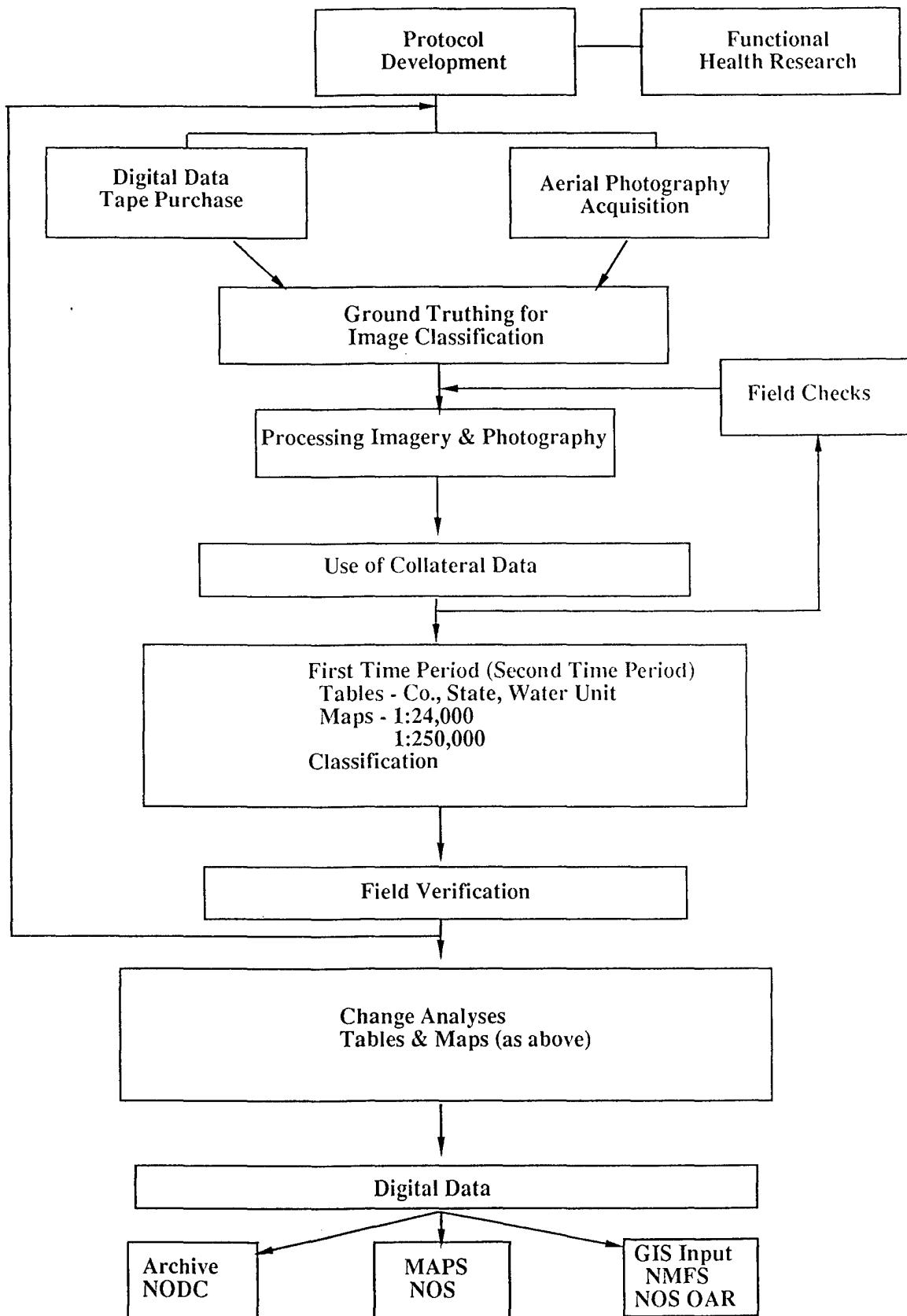

Fig. 4. Framework for protocol development.

change analyses for Metomkin Inlet, Virginia, and vicinity (1974–1982). During FY91, a statistical evaluation of the results, and additional protocol testing will take place.

*Task 3.* During FY90–91, researchers will continue a prototype effort to map SAV in the sounds of eastern North Carolina (Ferguson et al. 1989; Ferguson and Wood 1990). This task will use extant (1985 and 1988) and supplemental aerial photography at scales of 1:12,000 to 1:50,000 and will produce photographic scale tracings and 1:24,000-scale maps to document location, area, and change in area of SAV coverage. Photointerpretation of the presently available 1:12,000- and 1:20,000-scale photography (1985) will be completed for SAV in the area from Bogue Inlet to Drum Inlet. Photointerpretation of photography at the 1:24,000 scale (1988) will be completed in the area from Cape Lookout to Oregon Inlet. A portion of this photography (Cape Lookout to Drum Inlet, 1985, and Drum Inlet to Ocracoke Inlet, 1988) already has been interpreted, digitized, and published as a NOAA chart (Ferguson et al. 1989; Ferguson et al. 1991). The photography from 1988 overlaps this area and will allow change analysis between 1985 and 1988.

*Task 4.* In FY91, the protocol will be tested through a number of regional prototype demonstrations around the country (location and number determined in FY91). These regional prototypes will include regional representatives of each habitat-classified type and will be distributed along the coastal zone of the United States such that latitudinal, longitudinal, and tidal differences (i.e., vegetation type, height, biomass, season, and degree of inundation) will be considered. Special tests will be conducted to determine where and when water level changes affect the data from one period to the next. NOAA/State Estuarine Research Reserves, EPA/State National Estuary Program areas, and FWS refuges will be used, where appropriate, as sites for these demonstrations.

*Task 5.* In FY91, habitat classification and change analyses for emergent coastal wetlands and adjacent uplands will begin via the purchase of remotely sensed data tapes for the Gulf of Mexico or Atlantic coasts of the United States, depending on funding. Processing will begin in FY92. Purchase and processing of data tapes for the Pacific coast of the United States could occur as early as FY92–93, depending on funding. Repeat surveys of the Gulf of Mexico, Atlantic, or Pacific

coasts, or analyses of new coastal areas, could begin in FY94.

In FY92 and beyond, SAV mapping will be extended to include Florida, Texas, and other Gulf of Mexico and east and west coast States, and monitoring will be established for North Carolina. High-quality, baywide, digitized information about the annual distribution of SAV in Chesapeake Bay (Orth et al. 1990) already is available through the combined Federal/State Chesapeake Bay Program, with supplemental funding from the NOAA Coastal Zone Management Program to the States of Maryland and Virginia. Once the SAV mapping effort is in place in North Carolina and other States, repeat surveys for change analyses should take place every 2 to 4 years. These surveys will be merged with surveys of emergent wetlands and adjacent uplands to form an integrated mosaic.

*Task 6.* In FY91, depending on funding, researchers will begin to relate the functional health (biomass, primary and secondary productivity) of tidal wetlands to the spectral radiances observed through remote sensing. Our initial effort will be a literature survey and report describing previous research, status of technology and knowledge, and directions for future research. The literature survey serves two purposes: it will evaluate the potential for remote discernment of the functional health of emergent wetland types, and it will determine what additional field studies are needed to achieve this goal. The ultimate goal is to determine the conditions in which remote sensing can subclassify functional states of major habitat classifications.

Beyond FY91, based on the literature survey, wetland types of diverse functional health would be observed to seek spectral definitions of health and productivity. This effort would involve fieldwork such as that described by Crouse (1987) and Gross et al. (1987) who used hand-held radiometers to examine both affected and unaffected marsh areas. Hand-held radiometric measurements would be compared with concurrent spectral radiance measurements obtained from satellites (and perhaps aircraft) passing over the experimental sites. The plan is to study a series of experimental sites representative of different areas of the coastal zone of the United States. These areas will be selected in concert with the regional prototype demonstrations mentioned previously, as well as with sites used by NOAA (i.e., Coastal Ocean Program—Estuarine Habitat Studies) and other Federal and State programs (e.g., Mendelssohn and McKee 1985, 1987)



to develop information on natural versus anthropogenic stress-related alterations in biological productivity. Such information will be integrated with this effort in order to develop a more complete picture of the extent of estuarine habitat degradation, the processes active in bringing about such changes, and potential areas for subsequent field investigations.

*Task 7.* In FY91, depending on funding, data integration and analysis will be initiated to begin linking demographic patterns and habitat management practices to wetland stability or loss on an area-specific basis. Beyond FY91, studies are planned to relate wetland changes and fishery management practices to the success of estuarine and coastal ocean fisheries. Economic assessments of alternative management strategies will be included in these studies.

This task will require the cooperative efforts of a multidisciplinary team (i.e., demographers, wetland ecologists, fishery biologists, and economists) within and outside of NOAA, in order to integrate the diverse data generated by this program into a comprehensive geographic information system. The output ultimately would be used to develop models (e.g., Costanza et al. 1988) to assess present status and to predict future trends in coastal uplands, wetlands, and fisheries resources. Regional Fishery Management Councils, land-use planners, economists, and environmental managers require this information (Haddad and Ekberg 1987; Haddad and McGarry 1989) and will be encouraged to help plan for its generation.

## Acknowledgments

We thank R. Edwards, R. Lippson, and J. Pearce for ideas used in this paper. J. Dobson, K. Haddad, V. Klemas, P. Lade, R. Orth, and others provided technical advice. NOAA's habitat mapping working group, composed of R. Ferguson (NMFS), P. Grose (NOS), R. Lippson (NMFS), G. Mayer (OAR), R. Stumpf (NESDIS), and J. Thomas (NMFS), provided programmatic guidance.

## References

- Anderson J. R., E. E. Hardy, J. T. Roach, and R. E. Witmer. 1976. A land use and land cover classification system for use with remote sensor data. U.S. Geol. Surv. Prof. Pap. 964. 28 pp.
- Bartlett, D. S. 1987. Remote sensing of tidal wetlands. Pages 145–156 in V. Klemas, J. P. Thomas, and J. B. Zaitzeff, eds. Proceedings of a workshop on remote sensing of estuaries. U.S. Department of Commerce, the National Oceanic and Atmospheric Administration, and the U.S. Government Printing Office, Washington, D.C.
- Costanza, R., F. H. Sklar, M. L. White, and J. W. Day, Jr. 1988. A dynamic spatial simulation model of land loss and marsh succession in coastal Louisiana. Pages 99–114 in W. J. Mitsch, M. Straskraba, and S. E. Jorgensen, eds. Wetland modeling, developments in environmental modeling, 12. Elsevier Science Publishers B.V., Amsterdam.
- Cowardin, L. M., V. Carter, F. C. Golet, and E. T. LaRoe. 1979. Classification of wetlands and deepwater habitats of the United States. U.S. Fish Wildl. Serv., FWS/OBS-79/31. 103 pp.
- Crouse, V. 1987. Gauging the health of a salt marsh through remote sensing. Univ. Del. Sea Grant Rep. 6(1):1–5.
- Dobson, J. E. 1987. Geographic analysis for wetlands change detection. Pages 157–161 in V. Klemas, J. P. Thomas, and J. B. Zaitzeff, eds. Proceedings of a workshop on remote sensing of estuaries. U.S. Department of Commerce, the National Oceanic and Atmospheric Administration, and the U.S. Government Printing Office, Washington, D.C.
- Dobson, J. E., and E. A. Bright. 1989. Cover photo: Chesapeake Bay. Photogram. Eng. Remote Sens. 55(6).
- Ferguson, R. L., J. A. Rivera, and L. L. Wood. 1988. Seagrasses in southern Core Sound, North Carolina. National Oceanic and Atmospheric Administration–Fisheries submerged aquatic vegetation study, southern Core Sound, North Carolina. NOAA-Fisheries, Beaufort Laboratory, Beaufort, N.C. 28516.
- Ferguson, R. L., J. A. Rivera, and L. L. Wood. 1989. Submerged aquatic vegetation in the Albemarle–Pamlico estuarine system. Albemarle–Pamlico Estuarine Study, Project 88-10. North Carolina Department of Natural Resources and Community Development, Raleigh, N. C., and the U.S. Environmental Protection Agency, National Estuary Program, Washington, D.C. 68 pp.
- Ferguson, R. L., and L. L. Wood. 1990. Mapping submerged aquatic vegetation in North Carolina with conventional aerial photography. Pages 126–134 in S. J. Kiraly, F. A. Cross, and J. D. Buffington, Eds. Federal coastal wetland mapping programs. U.S. Fish Wildl. Serv., Bio. Rep. 90(18).
- Gross, M. F., M. A. Hardisky, V. Klemas, and P. L. Wolf. 1987. Quantification of biomass of the marsh grass (*Spartina alterniflora* Loisel) using Landsat Thematic Mapper imagery. Photogram. Eng. Remote Sens. 53(11):1577–1583.
- Haddad, K. D., and D. R. Ekberg. 1987. Potential of Landsat TM imagery for assessing the national status and trends of coastal wetlands. Pages 5192–5201 in O. T. Magoon, H. Converse, D. Miner, L. T. Tobin, D. Clark and G. Dormurat, eds. Coastal Zone '87. Proceedings of the fifth symposium on coastal and ocean management. American Society of Civil Engineers, New York.

- Haddad, K. D., and B. A. Harris. 1985. Use of remote sensing to assess estuarine habitats. Pages 662–675 in O. T. Magoon, H. Converse, D. Miner, D. Clark, and L. T. Tobin, eds. Coastal zone '85. Proceedings of the fourth symposium on coastal and ocean management. American Society of Civil Engineers, New York.
- Haddad, K. D., and G. McGarry. 1989. Basin-wide management: a remote sensing/GIS approach. Pages 1822–1836 in O. T. Magoon, H. Converse, D. Miner, L. T. Tobin and D. Clark, eds. Coastal zone '89. Proceedings of the sixth symposium on coastal and ocean management. American Society of Civil Engineers, New York.
- Kean, T. H., C. Campbell, B. Gardner, and W. K. Reilly. 1988. Protecting America's wetlands: an action agenda. The final report of the national wetlands policy forum. The Conservation Foundation, Washington, D.C. 69 pp.
- Klemas, V., and M. A. Hardisky. 1987. Remote sensing of estuaries: an overview. Pages 91–120 in V. Klemas, J. P. Thomas, and J. B. Zaitzeff, eds. Proceedings of a workshop on remote sensing of estuaries. U.S. Department of Commerce, the National Oceanic and Atmospheric Administration, and the U.S. Government Printing Office, Washington, D.C.
- Lade, P. K., D. Case, J. French, and H. Reed. 1988. Delineation and classification of submerged aquatic vegetation using SPOT satellite multispectral digital data. Final report (14 September) to the Maryland Department of Natural Resources, Tidewater Administration, Coastal Resources Division, Annapolis, Md. 53 pp. + Appendixes.
- Mendelssohn, I. A., and K. L. McKee. 1985. The effect of nutrients on adenine nucleotide levels and the adenylate energy charge ratio in *Spartina alterniflora* and *S. patens*. *Plant Cell Environ.* 8:213–218.
- Mendelssohn, I. A., and K. L. McKee. 1987. Effect of salinity on proline accumulation in three *Spartina* species. XIV International Botanical Congress, Berlin, Germany, 24 July–1 August.
- National Oceanic and Atmospheric Administration. (NOAA) 1985. National estuarine inventory data atlas. Vol. 1. Physical and hydrologic characteristics. U.S. Department of Commerce, Washington, D.C.
- Orth, Robert J., K. A. Moore, and J. F. Nowak. 1990. Monitoring seagrass distribution and abundance patterns: a case study from the Chesapeake Bay. Pages 111–123 in S. J. Kiraly, F. A. Cross, and J. D. Buffington, eds. Federal coastal wetland mapping programs. U.S. Fish Wildl. Serv., Biol. Rep. 90(18)
- Patterson, S. G. 1986. Mangrove community boundary interpretation and detection of areal changes on Marco Island, Florida: application of digital image processing and remote sensing techniques. U.S. Fish Wildl. Serv., Biol. Rep. 86(10). 87 pp.
- U.S. Congress. 1989. Coastal waters in jeopardy: reversing the decline and protecting America's coastal resources. Oversight Report of the Committee on Merchant Marine and Fisheries. Serial 100-E. U.S. Government Printing Office, Washington, D.C. 47 pp.

## National Oceanic and Atmospheric Administration's National Coastal Wetlands Inventory

by

Don W. Field, Anthony J. Reyer, Charles E. Alexander, Beth D. Shearer, and Paul V. Genovese

*National Oceanic and Atmospheric Administration  
National Ocean Service  
Office of Oceanography and Marine Assessment  
Ocean Assessments Division  
Strategic Assessment Branch  
6001 Executive Boulevard  
Rockville, Maryland 20852*

**ABSTRACT.**—A comprehensive and consistently derived data base describing the areal extent and distribution of coastal wetlands in the conterminous United States does not presently exist. We discuss efforts of the National Oceanic and Atmospheric Administration (NOAA) to develop such a data base using a systematic grid-sampling procedure on wetland maps produced by the National Wetlands Inventory (NWI) of the U.S. Fish and Wildlife Service. These maps, developed using areal photography, are generally based on 1:24,000-scale U.S. Geological Survey quadrangles; the maps identify wetland habitats classified using the Cowardin et al. (1979) system. The grid-sampling technique offers a reasonable alternative to more expensive and time-consuming techniques for quantifying NWI map information with a reasonable degree of accuracy and detail. Grid-sampled data are entered into the Spatial Analysis System, a microcomputer-based geographic information system published by Tydac Technologies Incorporated, for processing and manipulation. Digitized estuary boundaries and other study area boundaries can be intersected with grid-sampled data to produce acreage summaries and color maps for specific units of interest. Grid sampling of all 5,290 NWI maps available in coastal areas was completed in October 1989. The coastal wetlands inventory is one of several habitat elements in NOAA's program to develop a national estuarine assessment capability. These habitat elements will be incorporated into NOAA's National Estuarine Inventory Program along with other physical, hydrological, biological, and economic information to provide a more comprehensive understanding of estuarine environments.

The coastal wetlands project was initiated by the National Oceanic and Atmospheric Administration (NOAA) in June 1986 and is being conducted jointly by the Strategic Assessment Branch of the Ocean Assessment Division of the Office of Oceanography and Marine Assessment, National

Ocean Service, and the Beaufort Laboratory of the Southeast Fisheries Center, National Marine Fisheries Service (NMFS).

The coastal wetlands project is developing a comprehensive and consistent national coastal wetlands data base to increase our knowledge of

the distribution and areal extent of wetlands and to improve our understanding and management of this vital resource. The data developed from this project eventually will be incorporated into NOAA's National Estuarine Inventory (NEI) and will be used with other information, such as land use, coastal pollution, distribution of estuarine fishes and invertebrates, and the status of classified shellfish waters, to develop a national estuarine assessment capability.

The cornerstone of the NEI is the National Estuarine Inventory Data Atlas. Volume 1, completed in 1985, identifies 92 of the most important estuaries of the conterminous United States, and presents information through maps and tables on physical and hydrological characteristics of each. These estuaries represent about 90% of the estuarine water surface area and 90% of the freshwater inflow to estuaries of the east coast, west coast, and Gulf of Mexico. Volume 2, *Land Use*, presents area estimates for 7 categories and 24 subcategories of land use, as well as 1970 and 1980 population estimates. Volume 3, *Coastal Wetlands—New England*, is the first atlas in the wetlands series. This volume presents acreage estimates for 15 habitat types in 16 estuaries and 42 counties from Maine to Connecticut. Volume 4, *Public Recreation Facilities in Coastal Areas*, presents data for Federal, State, and locally owned recreation facilities in 327 counties and 25 estuary groups.

The goal of the NEI is to build a comprehensive framework for evaluating the health and status of the Nation's estuaries, and to bring estuaries into focus as a national resource base. The principal spatial unit for which all data are organized is the "estuarine drainage area," which is defined as "that land and water component of an entire watershed that most directly affects an estuary" (National Oceanic and Atmospheric Administration 1985). These data will be used to make comparisons, rankings, statistical correlations, and other analyses related to resource use, environmental quality, and economic values among estuaries. The main tool for performing these analyses will be NOAA's GeoCOAST facility. GeoCOAST is a hardware and software information facility developed by NOAA. GeoCOAST software consists of both commercial geographic information systems and NOAA-written packages. GeoCOAST provides the resources for developing and supporting systems used to store and analyze the spatial and temporal relation of data in coastal areas.

The data base and assessment capability under development for the NEI are part of a dynamic and evolving process. Other estuaries and subestuaries have been added to the NEI from around the country. Refinements are being made to physical and hydrological data estimated in Volume 1. Attributes such as volume and flushing rates have been added to the data base. Other NOAA projects for which data and information will be included in the NEI are the distribution of estuarine-dependent living marine resources; characterization of estuarine shoreline modification, navigational channels, and dredged material disposal areas; the quality of shellfish-growing waters and related projects; the National Coastal Pollutant Discharge Inventory; and the Inventory of Outdoor Coastal Recreation facilities<sup>1</sup>.

## Introduction

The Nation's coastal wetlands are an important natural resource. They provide critical habitat for fish, shellfish, and wildlife (Shaw and Fredine 1956; McHugh 1966; Turner 1977; Flake 1979; Lindal and Thayer 1982; Sather and Smith 1984), filter and process agricultural and industrial wastes (Kadlec and Kadlec 1979; Tchobanoglous and Culp 1980; Benner et al. 1982), and buffer coastal areas against storm and wave damage (Knutson 1982). They also generate large revenues from recreational activities such as fishing and hunting (National Marine Fisheries Service 1981; U.S. Fish and Wildlife Service 1982).

Rapid loss of wetlands is occurring in many areas because of urbanization, agriculture, hydrocarbon exploration, sea level rise, shoreline erosion, and other factors. More than 11 million acres of wetlands have been lost over the past 25 years (Frayer et al. 1983) because of human activity and natural processes. Although most of the losses have occurred in inland areas, coastal wetlands have also declined at an alarming rate over this period (about 20,000 acres [31 mi<sup>2</sup>] per year). Recent rates of wetland loss may be even higher in some States. For example, in coastal Louisiana, losses are estimated at 32,000 acres (50 mi<sup>2</sup>) per year (Day et al. 1981).

<sup>1</sup> Additional information on NOAA's National Estuarine Inventory is available from the Strategic Assessment Branch, Ocean Assessments Division, National Oceanic and Atmospheric Administration, 6001 Executive Boulevard, Rockville, Md. 20852, phone (301) 443-8843.

Despite increased awareness in the public and scientific sectors of the importance of coastal wetlands, no data base exists to document the current distribution and abundance of coastal wetlands. Recognizing this gap in wetlands information, the National Marine Fisheries Service and the Strategic Assessment Branch undertook a cooperative effort to compile the first comprehensive and consistent coastal wetlands data base. We describe these efforts and summarize the data compiled to date.

## Methods

### *Preliminary Investigations*

As a first step in establishing a coastal wetlands data base, NOAA examined and compiled existing data on the areal extent and distribution of coastal wetlands. Twenty-three sources were consulted in order to compile acreage figures for 242 counties in 22 coastal States (Alexander et al. 1986). These data indicated that more than 11 million acres of wetlands exist along the coastline of the conterminous United States. About 5 million acres were identified as swamp, 4.4 million acres as salt marsh, 1.5 million acres as fresh marsh, and 0.2 million acres as tidal flats. The Gulf of Mexico had the most wetlands (5.2 million acres), followed by the Southeast (4.2 million acres), the Northeast (1.7 million acres), and the west coast (0.2 million acres). Detailed information on data sources and a complete table of wetland types and acreages by coastal county are presented in two appendixes to the inventory.

While the compilation and evaluation of existing data were necessary first steps in establishing a national coastal wetland data base, much existing information is incomplete or outdated. Variability in data quality and consistency, and lack of a unifying theme or purpose, also contributed to the difficulty of consolidating data into a single, comprehensive data base. Therefore, our next step was to evaluate alternative sources of information. A key consideration was the ability to develop a data base in a timely and cost-effective manner.

Some investigators have successfully used multispectral scanner (MSS) and thematic mapper (TM) Landsat satellite imagery to inventory wetland habitats (Haddad and Harris 1985; May 1986). However, these techniques are beyond the resources of the project. A more realistic alterna-

tive was to use wetland maps produced by the National Wetlands Inventory (NWI) program of the U.S. Fish and Wildlife Service (FWS).

## The National Wetlands Inventory Program

The NWI program was established in 1975 to generate scientific information on the characteristics and extent of the Nation's wetlands, and to provide data for making quick and accurate resource decisions (Tiner 1984). This information was developed in two stages: (1) the creation of detailed wetland maps, and (2) research on historical status and trends. Since 1975, the FWS has produced thousands of detailed wetland maps, covering more than 60% of the conterminous United States and over 98% of the coastal zone. The maps are developed from aerial photography and are generally based on 1:24,000-scale U.S. Geological Survey (USGS) maps. They illustrate wetland habitats classified using the FWS's wetland classification system (Cowardin et al. 1979).

The NWI wetland maps represent the most reliable source of consistently derived coastal wetland information available. However, fewer than 2,000 of the more than 5,500 maps required for complete coverage of the Nation's estuaries and other coastal areas have been converted to digital data for computer processing and mapping. Therefore, only a fraction of the wetlands data required is available. Further, a complete digital data base of NWI coastal maps is not anticipated by FWS. Since the current procedure for digitizing is expensive and time-consuming, FWS presently digitizes maps primarily on a user-pays basis (Dahl 1987).

NWI maps remained, however, the preferred data source for this project because of their availability across broad coastal regions. For example, in the Gulf of Mexico region, 1,543 of about 1,850 maps needed for complete coverage of all coastal counties and 23 different estuarine systems are currently available from the FWS. Most maps not yet available are from areas not generally considered coastal.

### *Evaluating Grid-sampling Techniques*

Preliminary tests that used a grid-sampling technique on NWI maps indicated that this procedure could offer a reasonable alternative to more expensive and time-consuming techniques for quantifying NWI map information with a reason-

able degree of accuracy and detail (Field et al. 1988). To test this procedure, a simple grid-sampling technique was used to quantify habitat types for 16 previously digitized, 1:24,000-scale NWI maps. For the preliminary tests, the numerous habitat types designated on the NWI maps were aggregated into six general habitat categories: salt marsh, fresh marsh, tidal flats, swamp, open water, and uplands. After some testing, we determined that a 45-acre grid cell size was both efficient and accurate for estimating these six habitat types at this scale. We sampled each map separately by mounting a mylar grid sheet over the map and systematically recording the habitat type at each sampling point. The sampling took about 1 h. Based on the results (Table 1), it appeared that grid sampling could provide a time- and cost-effective technique for compiling a reasonably accurate coastal wetlands data base.

### NOAA's Coastal Wetlands Workshop

Before embarking on a national grid-sampling effort, the Strategic Assessment Branch and the National Marine Fisheries Service organized a workshop for professionals with experience in wetlands mapping and management to discuss NOAA's proposal to compile a national coastal wetlands data base. Sixteen professionals from six Federal organizations participated: U.S. Environmental Protection Agency, U.S. Army Corps of Engineers, USGS, FWS, National Marine Fisheries Service, and the National Ocean Service. Specific objectives of the workshop were to review current information on the distribution and extent of coastal wetlands and to solicit comments

Table 1. *Grid-sampling results for two test areas in coastal Louisiana and Texas (acres  $\times$  100.)*

Habitat	Digital	Grid	Difference %
Salt marsh	976	972	<-1
Fresh marsh	176	179	+2
Forested and scrub-shrub	12	11	-8
Tidal flats	80	79	-1
Open Water	4,349	4,320	-1
Upland	1,092	1,084	-1
<b>Total</b>	<b>6,685</b>	<b>6,645</b>	<b>-1</b>

and recommendations from the workshop participants on NOAA's proposed grid-sampling project.

In general, workshop participants supported NOAA's proposal to grid-sample NWI maps (National Oceanic and Atmospheric Administration 1986). Participants suggested, however, that the technique should be modified to improve the quality and usefulness of the data being developed. Two key recommendations were proposed:

- Expand the number of habitat types recorded. Participants said they believed that the six habitat types identified in the preliminary tests were inadequate and suggested a list of 11 habitat categories (Table 2). Since the workshop, 15 habitats have been incorporated into the project.
- Conduct a more complete statistical evaluation of the grid-sampling procedure.

These recommendations were examined by NOAA and incorporated into the operational phase of the project. The current grid-sampling technique is explained in detail in the following section. Grid sampling of available NWI maps began in June 1986.

Table 2. *The 15 habitat types identified in the grid-sampling procedure.*

Salt marsh
Brackish
High
Low
Unspecified <sup>a</sup>
Fresh marsh
Nontidal
Tidal
Unspecified <sup>a</sup>
Forested and scrub-shrub
Estuarine
Nontidal fresh
Tidal fresh
Unspecified fresh <sup>a</sup>
Tidal flats
Nonfresh open water
Fresh open water
Upland

<sup>a</sup>The unspecified categories were added to accommodate areas for which more specific information on salinity and water regime was not available.

### *The Grid-sampling Procedure*

The grid-sampling technique used to quantify coastal wetlands involves the placement of a transparent grid over an NWI map, and the identification of the wetland type on which each sampling point falls. The grid cells used in this procedure are 0.7 inches on a side, corresponding to about 45 acres when used on a 1:24,000-scale map. A small dot in the center of each grid cell is used as the sampling point. The exact number of sampling points varies with latitude and may contain between 800 and 1,000 sampling points.

Before sampling, the map name, State, scale, date of aerial photography, latitude and longitude of the lower right and upper left corners, and the number of columns and rows of grid cells are recorded. For this technique, the numerous wetland types identified on NWI maps were aggregated into 15 habitat types (Table 2). Each cell is recorded as the habitat type on which its center dot falls. A quality-control procedure is used to minimize the types of errors inherent in this technique. Coastal counties were grid-sampled to the extent of NWI map availability. Noncoastal counties were grid-sampled to the extent of NWI map availability for that portion of the county intersecting estuarine drainage area boundaries as defined in Volume 1 of NOAA's National Estuarine Inventory (National Oceanic and Atmospheric Administration 1985).

### *Geographic Information System Framework*

Grid-sampled data are entered into the Spatial Analysis System (SPANS), a microcomputer-based geographic information system (GIS) published by Tydac Technologies, Inc. SPANS allows for easy loading and manipulation of grid-sampled data, and displays and calculates acreage totals for the habitats found on each map. Hard copies are produced using a color ink-jet printer or a color wax transfer printer. Wetland acreage and map summaries can be produced by NWI map, county, State, or estuary.

The newest and one of the most useful aspects of the wetlands GIS capability is the SPANS map indexing module. The SPANS map indexing module is a GIS that has a level of resolution based on 1:24,000-scale maps as identified in the USGS topographic series. A multitude of information can be entered for each map, including location (latitude and longitude), date of aerial photography,

and the acreage of wetland types as identified in the grid-sampling process. The SPANS map indexing module will be a valuable tool in data-base management, and for many modeling functions to look at the distribution and abundance of coastal wetlands on a national scale.

### *Interpreting the Data*

Although the data used to compile this volume are the most complete and up-to-date available for the Nation's coastal regions, two major factors must be considered when interpreting the data: (1) the limitations of the sampling technique, and (2) the age of the photography used to produce the NWI maps.

#### **Technique Limitations**

As a result of discussions at NOAA's Coastal Wetlands Workshop, representatives from the USGS's National Mapping Division aided NOAA's wetlands team in determining if the 45-acre resolution was adequate for capturing coastal wetlands acreage with a reasonable degree of accuracy. Equations to determine acceptable sample size were calculated at several levels of acceptable error and degrees of confidence. These calculations indicated that the 45-acre cell size and subsequent 800 plus sampling points per 1:24,000-scale map were adequate for the development of wetlands data at the national, regional, and estuarine level of analysis.

Grid-sampled data, however, are not intended to be sufficiently accurate for making decisions at the site-specific level. In addition, the data are not intended to accurately estimate rare habitat types. But when these data are aggregated across a large geographic area, such as an estuary, they do provide an accurate summary of the general distribution and abundance of major wetland types.

#### **Age of Photography**

The date of aerial photography for the maps used in this study ranged from 1971 to 1985. The photography age also varied between regions. In New England, about 60% of the maps were produced from photography taken from 1975 to 1977, while about 20% of the maps were produced from 1980 and 1981 photography. The mid-Atlantic dates were slightly more recent, with 32% of the maps produced from photography taken from 1975 to 1978, and 43% from photography taken from 1979, to 1985. The photography for the Gulf of Mexico was generally the most recent, with 28% taken from 1979, and 42% from 1980 to 1984.

Analysis of these data is difficult because of the photography date range and because of a lack of regional data of comprehensive trends. As mentioned previously, losses in coastal Louisiana may be as high as 32,000 acres (50 mi<sup>2</sup>) per year (Day et al. 1981). However, in New Jersey, after 1970, about 50 acres of tidal wetlands were lost annually (Tiner 1985a). Likewise, in Delaware, from 1973 to 1979, about 20 acres of tidal wetlands were lost annually (Tiner 1985b). Because national trends indicate that the abundance of most wetland types is still declining (Frayser et al. 1983), the wetlands data presented in this report may represent more than the current amount of coastal wetlands.

## Results and Discussion

Grid sampling of all 5,290 NWI maps available in coastal areas was completed in October 1989. The figure illustrates the extent of NWI map availability for coastal areas in the conterminous United States. To date, data have been compiled by coastal county and estuarine drainage areas for 412 maps in New England (Maine to Connecticut), 735 maps in the mid-Atlantic (New York to Virginia), and 1,543 maps in the Gulf of Mexico (Florida to Texas). Data for the west coast (Washington to California) and the southeastern coast (North Carolina to Florida) have been processed and should be available by fall 1990.

Table 3 summarizes data by State for New England, the mid-Atlantic, and the Gulf of Mexico. In these regions, 92.2 million acres of land were inventoried using the grid-sampling process. Of this land, about 19%, or 17.7 million acres, was identified as wetlands. Forested wetlands were the dominant wetland type, accounting for 60% (10.7 million acres) of the total wetlands, followed by salt marsh (18%, 3.3 million acres), fresh marsh (16%, 2.8 million acres), and tidal flats (5%, 0.9 million acres).

A complete discussion on the distribution and abundance of coastal wetlands on a national scale will not be possible until data for the west coast and the southeastern coast have been processed. However, simple analysis of data for New England, the mid-Atlantic, and the Gulf of Mexico reveals the usefulness of these data as an indicator of the distribution and abundance of coastal wetlands on a regional scale. For example, the importance of Louisiana's extensive salt marshes has been recognized for a long time. Grid-sampled data indicate

that Louisiana contains more salt marsh than all States in New England, the mid-Atlantic, and the Gulf of Mexico combined, accounting for 53% of the salt marsh in these three regions. The Gulf coast of Florida is also extremely important, especially in terms of forested wetlands. About 5,032,100 acres of forested wetlands are on Florida's Gulf coast, accounting for 47% of the forested wetlands and 28% of the total wetlands in the three regions inventoried. Florida's Gulf coast also contains 1,405,600 acres of fresh marsh, accounting for 50% of the fresh marsh in the three regions inventoried.

Table 4 summarizes data for 47 estuarine drainage areas in New England, the mid-Atlantic, and the Gulf of Mexico. As with the State data given previously, it is impossible to have a complete discussion on the distribution of coastal wetlands in estuaries without data from the west coast and the southeastern coast. Once again, however, certain estuaries stand out, particularly the Mississippi Delta region and the Ten Thousand Island estuary on the southwest coast of Florida, ranked number one and two, respectively, in amount of total wetlands. With the exception of the Mississippi Delta region estuary, the Ten Thousand Island estuary contains nearly one million acres more of wetlands than any other estuary. This estuary is also ranked number one in amount of forested wetlands and fresh marsh. The Mississippi Delta region estuary contains over one million acres of salt marsh, which is three times the amount of the Ten Thousand Island estuary. It is also ranked second in amount of fresh marsh.

### *Comparisons with Fish and Wildlife Service Data*

To monitor the effectiveness of the grid-sampling technique, grid-sampled data are compared with NWI digital data whenever these data are available. While there are no complete digital data bases available for any Gulf coast state, the NWI has digitized an area approximately two to three maps in from the coast for most of the region. Digital data were obtained for five areas and compared to grid-sampled data (Table 5). These data were developed by the FWS by using the Map Overlay Statistical System (MOSS).

These data indicate that abundant wetland types, such as salt marsh in Galveston Bay and Laguna Madre, are estimated extremely well, while estimates for rare wetland types, such as forested wetlands in Galveston Bay, are some-



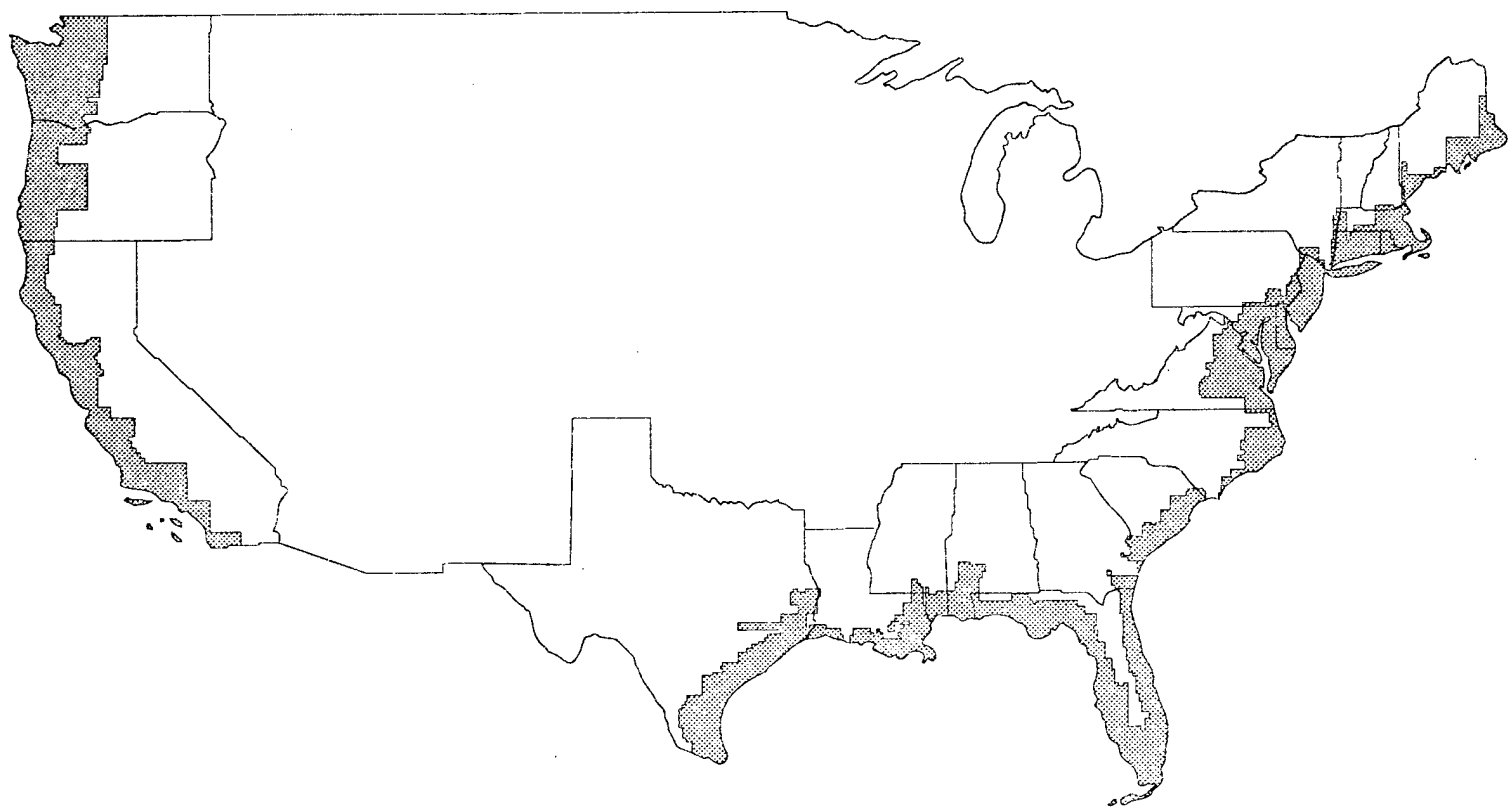

Figure. National Wetlands Inventory map availability in coastal areas of the conterminous United States.

times close to digital estimates but are generally more variable.

### *Product Schedule*

An atlas describing the distribution and abundance of coastal wetlands in 42 counties and 16 estuaries of the Northeast region (Maine to Connecticut) has been published, and another atlas containing data from 157 counties and 23 estuaries in the Gulf of Mexico (Texas to Florida) is due

to be published in the fall of 1990. A report describing the wetlands in 127 counties and 8 estuaries in the mid-Atlantic region (New York to Virginia) was distributed in May 1990, and a report on wetlands of the west coast was distributed in summer 1990. Data for the Southeast region (North Carolina to Florida) will be included in a national summary report (being done in cooperation with the FWS's National Wetlands Research Center and the NWI) scheduled for completion in April 1991.

Table 3. Coastal wetlands by state (Acres x 100)

State	Wetlands				Total Wetlands	Non-Wetlands			Total Acreage
	Salt Marsh	Fresh Marsh	Forested & Scrub-Shrub	Tidal Flats		Open Water	Upland	Subtotal	
Maine	215 (3) <sup>a</sup>	251 (3)	6,085 (80)	1,038 (14)	7,589 (15) <sup>b</sup>	6,246	37,349	43,598	69,103
New Hampshire	56 (7)	53 (6)	694 (81)	57 (6)	860 (10)	258	7,160	7,418	8,278
Massachusetts	471 (10)	315 (7)	3,521 (75)	382 (8)	4,689 (12)	2,291	32,394	34,685	39,374
Rhode Island	38 (6)	15 (2)	564 (85)	43 (7)	660 (8)	1,069	6,209	7,278	7,938
Connecticut	126 (8)	106 (7)	1,236 (81)	57 (6)	1,525 (5)	1,196	28,558	29,754	31,279
New York	297 (27)	59 (5)	345 (32)	392 (36)	1,092 (5)	2,280	17,152	19,433	20,525
New Jersey	1,936 (24)	325 (4)	5,283 (65)	641 (8)	8,186 (18)	1,755	36,182	37,938	46,123
Pennsylvania	0 (0)	48 (24)	155 (76)	<1 (<1)	204 (2)	271	10,849	11,120	11,324
Delaware	867 (39)	96 (4)	1,240 (55)	43 (2)	2,245 (17)	636	10,405	11,041	13,286
Maryland	2,042 (38)	158 (3)	2,896 (54)	299 (6)	5,394 (11)	4,074	40,820	44,894	50,288
District of Columbia	0 (0)	2 (50)	1 (50)	0 (0)	3 (<1)	44	470	514	517
Virginia	1,685 (23)	370 (5)	4,243 (58)	1,052 (14)	7,352 (8)	4,954	79,441	84,395	91,747
Georgia	0 (0)	23 (6)	334 (94)	0 (0)	357 (13)	50	2,288	2,338	2,695
Florida	2,542 (4)	14,056 (20)	50,321 (73)	1,930 (3)	68,849 (35)	11,638	118,199	129,837	198,686
Alabama	255 (2)	144 (1)	10,276 (96)	41 (1)	10,716 (24)	1,021	32,585	33,606	44,322
Mississippi	588 (8)	105 (1)	6,481 (90)	23 (1)	7,197 (25)	626	20,703	21,329	28,526
Louisiana	17,228 (52)	6,770 (20)	9,142 (27)	319 (1)	33,459 (47)	20,171	18,284	38,455	71,914
Texas	4,320 (26)	5,343 (32)	4,211 (25)	2,751 (17)	16,625 (8)	15,638	172,222	187,860	204,485

<sup>a</sup> Values in parentheses represent the percent of total wetlands

<sup>b</sup> Values in parentheses represent the percent of total acreage

Table 4. Coastal wetlands by estuarine drainage area (Acres x 100)

Estuary	Wetlands				Total Wetlands	Non-Wetlands			Total Acreage
	Salt Marsh	Fresh Marsh	Forested & Scrub Shrub	Tidal Flats		Open Water	Upland	Subtotal	
Passamaquoddy Bay	10 (1) <sup>a</sup>	51 (3)	1386 (90)	80 (6)	1527 (18) <sup>b</sup>	968	5,921	6,889	8,416
Englishman Bay	15 (1)	37 (3)	981 (87)	104 (9)	1,137 (18)	747	4,436	5,183	6,320
Narraguagus Bay	23 (4)	4 (1)	451 (79)	93 (16)	572 (20)	453	1,898	2,351	2,923
Blue Hill Bay	2 (<1)	16 (3)	486 (84)	73 (13)	577 (11)	1,073	3,611	4,684	5,261
Penobscott Bay	10 (1)	28 (3)	775 (79)	166 (17)	979 (11)	2,250	5,418	7,669	8,647
Muscongus Bay	2 (2)	1 (2)	58 (64)	29 (32)	90 (16)	68	422	490	580
Sheepscot Bay	50 (16)	28 (9)	117 (37)	119 (38)	314 (11)	581	2,003	2,584	2,898
Casco Bay	24 (6)	15 (4)	167 (43)	186 (47)	393 (8)	1,287	3,211	4,498	4,891
Saco Bay	29 (6)	40 (8)	413 (82)	18 (4)	500 (9)	327	4,606	4,934	5,433
Great Bay	27 (5)	19 (4)	396 (78)	67 (13)	509 (13)	168	3,165	3,333	3,842
Merrimack River	23 (4)	48 (8)	535 (86)	11 (2)	617 (9)	214	5,809	6,024	6,640
Boston Bay	18 (4)	37 (9)	305 (69)	79 (18)	439 (10)	522	3,547	4,069	4,508
Cape Cod Bay	106 (23)	25 (5)	91 (20)	241 (52)	463 (19)	832	1,153	1,985	2,448
Buzzards Bay	41 (9)	82 (17)	312 (64)	48 (10)	483 (13)	1,468	1,871	3,339	3,822
Narrangansett Bay	38 (4)	62 (6)	864 (88)	24 (2)	988 (11)	1,290	6,424	7,714	8,702
Connecticut River	31 (8)	43 (12)	289 (79)	4 (1)	367 (5)	236	6,523	6,759	7,126
Gardiners Bay	33 (24)	3 (2)	30 (21)	74 (53)	141 (5)	1,139	1,633	2,771	2,912
Long Island Sound	161 (8)	116 (6)	1,586 (79)	153 (8)	2,016 (5)	5,793	35,498	41,291	43,307
Great South Bay	183 (41)	2 (0)	44 (10)	219 (49)	447 (8)	893	4,021	4,914	5,362
Hudson River	168 (10)	147 (8)	1,243 (72)	162 (9)	1,719 (7)	1,791	21,302	23,093	24,812
Barnegat Bay	416 (17)	35 (1)	1,710 (70)	299 (12)	2,460 (29)	547	5,524	6,070	8,530
Delaware Bay	1,472 (36)	241 (6)	2,202 (54)	187 (4)	4,102 (14)	3,561	20,920	24,481	28,583
Chincoteague Bay	249 (68)	2 (1)	73 (20)	44 (12)	368 (18)	800	901	1,700	2,068
Chesapeake Bay	2,779 (28)	508 (5)	5,685 (57)	990 (10)	9,962 (7)	23,116	105,290	128,410	138,368
Ten Thousand Islands	548 (2)	8,076 (37)	12,616 (58)	409 (2)	21,650 (76)	1,004	5,644	6,688	28,338
Charlotte Harbor	68 (1)	2,896 (46)	2,713 (44)	562 (9)	6,240 (20)	2,259	22,181	24,440	30,680
Tampa Bay	31 (1)	466 (18)	1,647 (65)	376 (15)	2,520 (16)	2,323	10,817	13,140	15,660
Suwanee Bay	209 (9)	176 (8)	1,902 (83)	3 (<1)	2,290 (20)	455	8,419	8,874	11,164
Apalachee Bay	244 (4)	254 (4)	6,368 (92)	88 (1)	6,954 (32)	1,300	13,553	14,853	21,807
Apalachicola Bay	170 (3)	87 (2)	5,585 (94)	75 (1)	5,917 (50)	1,581	4,168	5,749	11,666
St. Andrew Bay	85 (3)	28 (1)	2,362 (94)	35 (1)	2,511 (33)	679	4,318	4,997	7,508
Choctawhatchee Bay	27 (1)	37 (1)	2,679 (96)	58 (2)	2,801 (21)	975	9,384	10,359	13,160
Pensacola Bay	67 (3)	61 (2)	2,297 (94)	20 (1)	2,445 (19)	1,001	9,199	10,200	12,645
Perdido Bay	19 (1)	18 (1)	1,657 (97)	7 (<1)	1,702 (22)	324	5,671	5,995	7,697
Mobile Bay	170 (3)	72 (1)	6,273 (96)	30 (<1)	6,545 (23)	2,882	19,122	22,004	28,549
Mississippi Sound	1,706 (16)	432 (4)	8,477 (79)	74 (1)	10,689 (22)	11,057	21,112	32,169	42,858
Mississippi Delta Region	10,429 (59)	3,325 (19)	3,788 (21)	151 (1)	17,693 (40)	21,256	2,564	23,820	41,513
Atchafalaya and Vermillion Bays	1,265 (27)	1,026 (22)	2,304 (50)	19 (<1)	4,614 (30)	4,312	4,037	8,349	12,963
Calcasieu Lake	826 (68)	329 (27)	<1 (<1)	65 (5)	1,220 (33)	1,375	1,127	2,502	3,722
Sabine Lake	1,100 (28)	852 (22)	1,871 (47)	114 (3)	3,937 (19)	1,374	15,710	17,084	21,021
Galveston Bay	949 (40)	589 (25)	744 (31)	110 (5)	2,392 (11)	4,258	15,495	19,753	22,145
Brazos River	3 (2)	68 (34)	126 (64)	<1 (<1)	197 (3)	234	5,661	5,895	6,092
Matagorda Bay	435 (51)	289 (34)	70 (8)	64 (8)	858 (5)	2,181	15,105	17,286	18,144
San Antonio Bay	328 (49)	283 (42)	22 (3)	35 (5)	668 (20)	1,484	1,118	2,602	3,270
Aransas Bay	307 (32)	420 (43)	108 (11)	139 (14)	974 (6)	1,623	12,992	14,615	15,589
Corpus Christi Bay	122 (41)	73 (25)	14 (5)	87 (29)	296 (4)	1,533	5,376	6,909	7,205
Laguna Madre	678 (15)	1,933 (43)	226 (5)	1,668 (37)	4,506 (6)	3,776	60,821	64,597	69,103

<sup>a</sup> Values in parentheses represent the percent of total wetlands grid sampled by NOAA

<sup>b</sup> Values in parentheses represent the percent of total estuarine drainage area grid sampled by NOAA that is wetlands

Table 5. NOAA grid sampled data vs U.S. Fish and Wildlife Service digital data for five estuaries in the Gulf of Mexico. Aggregates of ten to 15 maps were compared in each estuary.

Region	Salt Marsh	Fresh Marsh	Forested	Tidal Flats	Total Wetlands	Upland	Open Water
<b>Mobile Bay</b>							
NOAA	11,075	1,382	43,244	3,594	59,295	59,655	239,074
Fish & Wildlife	11,047	1,340	44,585	3,211	60,183	60,699	238,786
% Difference	0.3	3.1	-3.0	11.9	-1.5	-1.7	0.1
<b>Tampa Bay</b>							
NOAA	1,839	5,348	14,259	29,445	50,901	65,166	156,208
Fish & Wildlife	1,580	4,577	15,341	28,361	49,859	65,247	157,584
% Difference	16.4	16.8	-7.1	3.8	2.1	-0.1	-0.9
<b>Mississippi Delta</b>							
NOAA	29,512	65,198	5,169	765	100,644	100,734	511,884
Fish & Wildlife	29,930	65,666	5,326	727	101,649	101,870	510,727
% Difference	-1.4	-0.7	-2.9	5.2	-1.0	-1.1	0.2
<b>Galveston Bay</b>							
NOAA	78,557	9,592	315	8,139	96,603	96,783	275,158
Fish & Wildlife	77,644	9,296	488	7,801	95,229	95,402	267,040
% Difference	-1.2	-3.2	35.5	-4.3	1.4	-1.4	-3.0
<b>Laguna Madre</b>							
NOAA	31,762	22,922	193	97,469	152,346	152,751	143,907
Fish & Wildlife	31,204	23,508	229	97,588	152,529	152,756	143,876
% Difference	-1.8	2.5	15.7	0.1	-0.1	0.0	0.0

## References

- Alexander, C. E., M. A. Broutman, and D. W. Field. 1986. An inventory of coastal wetlands of the USA. Strategic Assessment Branch, National Oceanic and Atmospheric Administration, Rockville, Md. 25 pp. [unpublished manuscript]
- Benner, C. S., P. L. Knutson, R. A. Brochu, and A. K. Hurme. 1982. Vegetative erosion control in an obligohaline environment, Currituck Sound, North Carolina. In Third annual meeting of the Society of Wetland Scientists, Wrightsville Beach, N.C.
- Cowardin, L. M., V. Carter, F. C. Golet, and E. T. La Roe. 1979. Classification of wetlands and deepwater habitats of the United States. U.S. Fish Wildl. Serv., FWS/OBS-79/31. 103 pp. Washington, D.C.
- Dahl, T. E. 1987. Wetlands mapping in the coastal zone—progress towards creating a national data base. Pages 465–473 in Proceedings of coastal zone '87. Vol. 1. Seattle, Wash.
- Day, J. W., Jr., and N. J. Craig. 1981. Comparison of effectiveness of management options for wetlands loss in the coastal zone of Louisiana. Pages 232–239 in Proceedings, conference on coastal erosion and wetland modification in Louisiana: causes, consequences, and options. U.S. Fish Wildl. Serv., FWS/OBS-82/59.
- Field, D. W., C. E. Alexander, and M. A. Broutman. 1988. Towards developing an inventory of coastal wetlands of the USA. Mar. Fish. Rev. 50(1):40–46.
- Flake, L. D. 1979. Wetland diversity and waterfowl. Pages 312–319 in P. E. Greeson, J. R. Clark, and J. E. Clark, eds. Wetland functions and values: the state of our understanding. American Water Resources Association. Minneapolis, Minn.
- Fraye, W. E., T. J. Monahan, D. C. Bowden, and F. A. Graybill. 1983. Status and trends of wetlands and deepwater habitats in the conterminous United States, 1950's to 1970's. Department of Forest and Wood Sciences, Colorado State University, Fort Collins. 32 pp.
- Haddad, K. D., and B. A. Harris. 1985. Use of remote sensing to assess estuarine habitats. Pages 662–675 in O. T. Magoon, ed. Coastal zone '85. Proceedings of the fifth symposium on coastal and ocean management Vol 1. American Society of Civil Engineers, New York.
- Kadlec, R. H., and J. A. Kadlec. 1979. Wetlands and water quality. Pages 436–456 in P. E. Greeson, J. R. Clark, and J. E. Clark, eds. Wetland functions and values: the state of our understanding. American Resources Association. Minneapolis, Minn.
- Knutson, P. L., and W. N. Selig. 1982. Wave damping in *Spartina alterniflora* marches. In Third annual meeting of wetlands scientists. Wrightsville Beach, N.C.
- Lindall, W. N., Jr., and G. W. Thayer. 1982. Quantification of National Marine Fisheries Service habitat conservation efforts in the Southeast region of the United States. Mar. Fish. Rev. 44:18–22.
- May, L. N., Jr. 1986. An evaluation of Landsat MSS digital data for updating habitat maps of the Louisiana coastal zone. Photogram. Eng. Remote Sens. (52)8:1147–1159.
- McHugh, J. L. 1966. Management of estuarine fisheries. Am. Fish. Soc. Spec. Publ. 3:133–154. Washington, D.C.
- National Marine Fisheries Service. 1981. Fisheries of the United States, 1980. Current fishery statistics 8100, U.S. Department of Commerce, National Oceanic and Atmospheric Administration, Washington, D.C. U.S. Government Printing Office. 132 pp.
- National Oceanic and Atmospheric Administration. 1985. National estuarine inventory data atlas: physical and hydrologic characteristics. Office of Oceanography and Marine Assessment, Strategic Assessment Branch. Rockville, Md. 103 pp.
- National Oceanic and Atmospheric Administration. 1986. Summary of proceedings: NOAA coastal wetlands workshop. Office of Oceanography and Marine Assessment, Strategic Assessment Branch, Rockville, Md. 11 pp. [unpublished manuscript]
- Sather, J. H., and R. D. Smith. 1984. An overview of major wetland values and functions. U.S. Fish Wildl. Serv., FWS/OBS-84/18. 68 pp.
- Shaw, S. P., and C. G. Fredine. 1956. Wetlands of the United States: their extent and their value to waterfowl and other wildlife. U.S. Fish Wildl. Serv., Circ. 39. 67 pp.
- Tchobanoglous, G., and G. L. Culp. 1980. Wetland systems of wastewater treatment: an engineering assessment. University of California, Davis.
- Tiner, R. W., Jr. 1984. Wetlands of the United States: current status and recent trends. U.S. Fish and Wildlife Service, National Wetlands Inventory, Washington, D.C. 59 pp.
- Tiner, R. W., Jr. 1985a. Wetlands of New Jersey. U.S. Fish and Wildlife Service, National Wetlands Inventory, Newton Corner, Mass. 117 pp.
- Tiner, R. W., Jr. 1985b. Wetlands of Delaware. U.S. Fish and Wildlife Service, National Wetlands Inventory, Newton Corner, Mass., and Delaware Department of Natural Resources and Environmental Control, Wetlands Section, Dover, Del. Coop. Publ. 77 pp.
- Turner, R. E. 1977. Intertidal vegetation and commercial yield of penaeid shrimp. Trans. Am. Fish. Soc. 106:411–416.
- U.S. Fish and Wildlife Service. 1982. The national survey of fish, hunting, and wildlife-associated recreation. U.S. Government Printing Office, Washington, D.C. 132 pp.

# Overview of the Land-Sea Interface Research Program

by

Armond T. Joyce, Richard L. Miller, and Ramona E. Pelletier

*Science and Technology Laboratory  
Building 1100  
National Aeronautic and Space Administration  
Stennis Space Center, Mississippi 39529*

**ABSTRACT.**—The general goal of the Earth Sciences Research Program at the NASA/Stennis Space Center Science and Technology Laboratory is to provide a better understanding of the state and dynamics of global biological, chemical, and physical processes under natural and anthropogenic perturbations. Our research is conducted by using remotely sensed data acquired by a variety of sensors operated on a truck boom, aircraft, and spacecraft. Although some studies are site-specific, our overall objective is to gain information and knowledge that would allow modeling from a global perspective. Research is conducted through a team approach with a multidisciplinary staff. We give preference to developing joint research projects with university faculty or other external investigators in order to form an appropriate team for each particular research objective. Collaborative research with external investigators is also aided through the Resident Research Associateship Program administered through the National Research Council, the Summer Faculty Program, and a Summer Visiting Scientist-Lecturer Program.

The Stennis Space Center Science and Technology Laboratory (SSC/STL) Research Program has three main focuses: forest ecosystems research, land-sea interface, and soils and geological research. This research takes place in many separate projects; however, each of these interrelated projects is a component of a research program aimed at understanding the functioning of the ecosystem being addressed. The Land-Sea Interface Research Program at SSC/STL views the land-sea interface in an ecosystem context, including both the terrestrial component and the nearshore waters.

## Wetlands Productive Capacity Modeling

This project combines remote-sensing analysis, field studies in the Grand Bayou, Louisiana, watershed, and mathematical modeling to examine the coupling between the production of detritus (dead organic matter) in wetlands and the yield of coastal fisheries. Thematic Mapper (TM) data have been used successfully to estimate the standing crop biomass in the marsh through the use of regression equations. Two types of regression equations were employed; those that used raw digital counts and others that used ratioed data from different bands (reflectance ratio and vegetation index). Our remote-sensing analysis, combined with field studies, suggests that wetland loss results in a watershed net aboveground primary production (NAPP) decrease of 4%, whereas con-

trolled burning results in a watershed NAPP decrease of 2 to 20% (6% average between 1978 and 1985). This work is described in further detail in the proceedings of the 1987 symposium of the Society of Wetland Scientists (Dow et al. 1989).

## Spectral Studies

Our past research efforts characterized the spectral curves exhibited by different species of marsh plants in the field, and measured the spectral response of *Spartina alterniflora* grown in hydroponic culture in the laboratory to salinity and waterlogging stresses. The field studies of marsh plant spectra measured 6 replicates of live and dead leaves for 11 different species characteristic of the saline, brackish, intermediate, or fresh water marshes at Grand Bayou, Louisiana. *Spartina patens* was collected from the brackish and interme-

diate marsh salinity zones, while *S. alterniflora* was collected from the brackish and saline marsh zones. The marsh salinity zone does not seem to change the characteristic spectra of *S. alterniflora* or *S. patens*.

In the laboratory studies of *S. alterniflora* grown in hydroponic culture for 6 weeks at 5 salinity levels (0, 6, 12, 24, and 35 ppt) and 3 different levels of waterlogging (drained, saturated, and submerged), the rate of leaf expansion and photosynthetic rate manifested stress responses at salinity levels above 24 ppt. I. A. Mendelsohn and coworkers of the Laboratory for Wetland Soils and Sediments at Louisiana State University (LSU) made the growth measurements and conducted assays for leaf proline (a general indicator of plant salinity or water stress). These data are being statistically analyzed on an individual replicate basis in comparison with the moisture stress index (% reflectance at 1650 nm/% reflectance at 1260 nm). The wealth of growth, biochemical assay (proline levels, root alcoholic dehydrogenase levels), and elemental concentrations measured for each treatment by LSU researchers should provide a basis for interpreting the spectral response curves.

## Biogeochemical Flux Estimation

Wetlands are the focus of our research because of their production of trace gases of carbon, nitrogen, and sulfur, which may modify the earth's climate through the "Greenhouse Effect", and because of the potential role of some trace gases in controlling the stratospheric ozone layer, which protects the earth from ultraviolet radiation. The wetlands biogeochemical flux project is a joint effort being conducted by the Stennis Space Center Science and Technology Laboratory, Langley Research Center, and the South Florida Research Laboratory at the Everglades National Park.

The objectives of this project are to (1) examine the capabilities of current remote-sensing instruments to delineate certain wetland vegetation types, and (2) develop and test a geographic information system (GIS) for estimating trace gas emissions from wetland ecosystems. Our past efforts focused on methane estimates; however, because the data-base requirements are quite similar for other trace gas estimation models, our future efforts will include GIS model development for nitrogen and sulfur trace gases as well.

Our results so far indicate that the analysis of TM data provides the most accurate classification of pertinent vegetation types that are correlated with methane emission (Dow et al. 1987). However, the combination of cloudy weather and infrequent TM coverage has led to an evaluation of the suitability of Advanced Very High Resolution Radiometer (AVHRR) data to classify vegetation because of its frequent coverage, despite its coarser spatial resolution (1 km). Daytime AVHRR data had demonstrated some promise as an indicator of inundation extent (Pelletier and Dow 1989). We are now evaluating both day and night acquisitions to better understand seasonal inundation variation, which is directly related to the anaerobic conditions necessary to methanogenesis and the production of other "greenhouse" gases.

This project also addresses the following objectives: (1) estimating the vertical extent of inundation by incorporating detailed topographic data and ancillary precipitation and stage data; (2) monitoring dynamics of seasonal variation by modeling temporal changes in water flow patterns during a typical year; and (3) estimating potential minimum and maximum inundation states for selected years exhibiting extreme ranges between wet and dry seasons.

In our initial modeling efforts, we developed spatial distributions of five methane flux classes for a typical wet season period and another for a typical dry season period. TM data were acquired from a December overpass and classified into 13 distinct vegetation classes. In situ methane flux measurements were collected by using these categories as a sampling guide. Based on these flux readings, the 13 vegetation classes were recombined into 5 statistically significant vegetation/flux classes. The inundation status was determined from the vegetation/flux classification to represent dry season and wet season periods, and new methane flux distribution maps were developed. These results are reported in a journal article (Bartlett et al. 1989). While our efforts to date have been focused in the Everglades, we plan to expand our research to larger geographic areas.

## Airborne Electromagnetic Profiles Research

Many of today's typical airborne or spaceborne remote-sensing devices are relatively surface-oriented. Because soils have a large component beneath the surface, many of these surface-

oriented sensors are notably limited in characterizing properties of the whole soil. Surface conditions can often be determined and some subsurface conditions inferred, but the subsurface condition inferences are not always reliable. These concerns are exacerbated if the soil or sediment material is submerged, as is true in many wetland and shallow coastal areas. In these situations, not only is the subsurface inaccessible to most remote sensors, but the soil surface is also obscured by a layer of water.

In this research, NASA is cooperating with the Naval Oceanographic and Atmospheric Research Laboratory in evaluating the capabilities of the new Airborne Electromagnetic (AEM) Profiler. The AEM Profiler is an active helicopter-borne sensor working in the 90–4500 Hz range. The system was primarily developed for mapping bathymetry in relatively shallow marine environments, but it also is useful in assessing a number of physical properties for water and underlying sediment. Because the AEM Profiler has multi-frequency capability, these physical properties can be differentially determined at multiple depths within the soil or sediment profile. Water properties, such as salinity and temperature, and soil information, such as bulk density, porosity, organic matter content, and generalized mineralogy, can be determined.

Submerged sediment data can be valuable for both commercial (e.g., monitoring sediment dynamics in shipping channels) and scientific applications (e.g., soil and sediment mapping, monitoring coastal geomorphology, and modeling marsh processes dependent on soil conditions and water depth). This research program is trying to merge AEM Profiler data with more traditional surface-oriented sensor data. This will give three-dimensional depictions of shallow, submerged coastal areas. We have acquired and are analyzing data from a barrier island environment at Cape Lookout, North Carolina. Preliminary analysis from that data set is reported by Pelletier and Wu (1989). Additional AEM Profiler missions are planned for the Louisiana coast, and an inland wetland area in northeastern Canada.

## Coastal Geomorphology

Previous work by the Coastal Studies Institute at LSU has raised questions about the relative significance of hurricanes in controlling the coastal sediment budget. The institute's work has

strongly suggested that a much more significant driving force in controlling the coastal sediment budget is the passage of intense cold fronts during the winter months. While a hurricane is intense, it is relatively localized, only affecting a length of coast about 100 miles. Furthermore, for any given piece of shoreline, the mean time between hurricanes is about 33 years. In comparison, winter storms occur 30 to 40 times every year, and sweep over almost the entire coastal area. Also, the processes that occur during the passage of winter storms seem to maximize their effectiveness in moving sediment.

The purpose of our research is to examine the responses of the sediment, water, and atmosphere at and near the coast to the passage of these cold fronts. In cooperation with members of the Coastal Studies Institute, we hope to determine how important these fronts are as "engines" for sediment transport and deposition (Roberts et al. 1987).

Geometric registration of remotely sensed data is a major concern, as the features being studied have several spatial scales, change as a function of time, and are not shown on maps. This concern has led to the development of a fundamentally new georeferencing software system inside the Earth Resources Laboratory Applications (ELAS) software package. The design and the results of testing this software are presented in Rickman et al. (1988).

## Wetlands Change Detection

Many of Louisiana's wetlands are rapidly degrading. Multitemporal remotely sensed data can be quite useful in identifying the location, amount, and type of change taking place. The pattern of change that often occurs in wetland environments, such as those in Louisiana, consists of small scattered spots that gradually grow in size, unlike the concentric or corridor growth patterns generally associated with urban change. Many traditional means of detecting change in digital data have required that the data sets be geographically rectified to a high degree of accuracy. In wetland environments undergoing significant change, high-confidence control points for adequate georegistration precision may be quite limited.

The Science and Technology Laboratory has developed a change detection technique that does not require the data sets to exhibit a strict degree of geographic coregistration. Instead, our technique uses a gridding approach to partition the



data into segments; these segments are classified by land cover and then compared with geographically similar segments in the second data set. Although slight misalignment might cause significant overestimation of change when compared on a pixel by pixel basis, when grouped into grids or multiple pixels the error is averaged out so that a more accurate estimate of real change can be calculated.

The test data chosen for a preliminary evaluation of this gridding technique were two Landsat Multispectral Scanner (MSS) data sets (1972 and 1981) for the Cameron-Creole watershed in Louisiana. Test grid sizes ranged from  $1 \times 1$  pixels to  $50 \times 50$  pixels. Grids from  $5 \times 5$  pixels up to perhaps  $10 \times 10$  pixels provided calculated change estimates from slightly to moderately misregistered data sets that were comparable in accuracy with pixel by pixel calculations from almost perfectly registered data sets. Grid sizes larger than  $10 \times 10$  pixels tended to begin canceling out the influence of relatively small spots of change. Details from this initial study are reported by Pelletier and Dow (1987).

## Wetlands Landscape Modeling

The Louisiana coast has many marsh conditions, including rapidly subsiding, aggrading, and those that seem to be in relative equilibrium. Because of Louisiana's variety of marsh conditions, its coast has been an excellent location for modeling the impact of changing sea level on a variety of marsh conditions. We take theoretical and actual cross sections of marsh landscapes from different marsh types and modeled them for sea level effect over various time intervals and rates of sea level rise. The key variables being monitored are horizontal and vertical marsh topographic conditions, sedimentation rate, organic accretion rate, subsidence rate, toxic sulfide species concentrations, and above- and belowground plant biomass. A spatial perspective for three-dimensional analyses of landscape change is permitted by extrapolating between a series of marsh topographic transects.

Results from the models provide an innovative means for visualizing how streamside segments are capable of persisting for many years because of higher sediment load and lower accumulation of toxic sulfide species when compared with the more rapidly degrading back-marsh segments (Pelletier 1987). While subsidence-dominated marshes are in immediate danger of degrading at the present

rate of rise in eustatic sea level, the model predicts that marshes previously considered "stable" are in danger of significant submergence during the next 50 to 100 years, even if the present rate of sea level rise is only doubled. If sea level rise quadruples from the present rate (well within the range suggested by Hansen et al. 1985), sedimentation-dominated aggrading marshes would be in danger of submergence. We need more fieldwork and modeling activities to better understand the coping mechanisms marshes have to counteract sea level fluctuations.

Our research continues to improve the model and to provide for a three-dimensional perspective of multiple data transects in the model. We are modifying the model to accept data from AEM Profiler studies as one source of input data. Ultimately, this model will be incorporated into geographical information systems of coastal regions, along with remotely sensed and ancillary data sources for many biological and physical land-sea interface models.

## Land-Sea Interface

In 1986, Stennis Space Center Science and Technology Laboratory and the University of Puerto Rico (UPR) began a multiyear cooperative research project to improve the understanding of exchange processes between terrestrial and marine ecosystems. Participating investigators are faculty and graduate students from the Departments of Marine Science and Engineering at the UPR Mayaguez Campus, and the staff of the Divisions of Terrestrial and Marine Ecology of the Center for Energy and Environment Research.

During fiscal year (FY) 1988, much of our work was devoted to enhancing the project's ability to process and analyze ocean color imagery derived from the Coastal Zone Color Scanner (CZCS), the Airborne Ocean Color Imager (AOCI), and the Calibrated Airborne Multispectral Scanner (CAMS). A series of software modules was developed to process these data within the ELAS operating environment. In particular, an integrated set of interactive modules was developed to compute near-surface chlorophyll concentrations with CZCS data; these modules apply the clear water radiance method for atmospheric correction, corrections for orbital and radiometric decay, and bio-optical algorithms. Atmospheric correction algorithms and optical algorithms to compute chlorophyll and suspended sediment concentrations

for AOCI and CAMS data are now being developed. In addition, all ocean color software models are being transported to operate in the personal computer environment.

Our FY88 activities focused on the large Guanajibo watershed (which discharges into waters along the west coast of Puerto Rico) and an intensive study site encompassing the Joyuda Lagoon within the Guanajibo watershed. We used Landsat TM data to generate a land cover classification for the entire Guanajibo watershed, and use CAMS data acquired during 1987 to generate a more detailed land cover classification of the Joyuda Lagoon watershed. Soils maps and contour lines on topographic maps were digitized, and the resulting data were assembled, together with the land cover data, in a geographically referenced data base.

We used the soils, land cover, and topographic data to develop a method for implementing the Universal Soil Loss Equation (USLE) on a regional scale for the Guanajibo area of western Puerto Rico. This task not only evaluated erosion conditions of the land itself, but it also developed a baseline for assessing sediment effects on the coastal environment. Soil erosion from the mountainous and agricultural regions within the Guanajibo has contributed greatly to the sediment influx in adjacent coastal regions. These soils are inherently highly erodible, and the area's high rainfall and increased agricultural pressure on the land magnifies the erosion problem. Although the resulting sediments delivered to the coastal waters bring some nutrients, they also tend to screen much of the life-giving light from the area's phytoplankton and coral. A good understanding of potential sediment load due to erosion from the terrestrial environment would be helpful to models of coastal marine ecology.

In order to address future land-sea interface issues, we will continue to transform soil erosion values from models such as the USLE into more likely values of actual sediment influx to the marine environment on a variety of temporal scales.

Another aspect of this coastal ecosystem study focused on the amount and movement of organic carbon from terrestrial sources through estuaries and lagoons. The principal study site for this project is the Joyuda Lagoon, a mangrove-fringed lagoon on the west coast of Puerto Rico; the lagoon that is fed by a small watershed and exchanges with the sea through a narrow canal. The UPR and Center for Energy and Environmental Research

investigators designed a program of measurements leading to the development of material balances for water, salt, carbon, nitrogen, and phosphorous. All processes that contribute or remove these materials will be evaluated. Automated tidal and steam gauging is being conducted in a joint project with the U.S. Geological Survey (USGS). Groundwater flows from drilled wells are being assessed, and automated meteorological observations are being made. Investigators took water samples to measure water mass chlorophyll content while acquiring data with the CAMS in March 1987. Spectral data for mangrove leaves have been acquired with a ground-operated imaging spectrometer. This instrument measures reflectance from 0.38 to 2.5 microns in very narrow bandwidths. The investigators made measurements for mangrove leaves across salinity gradients and at a site in the lagoon that has high concentrations of nickel. The preliminary results of these analyses were reported at the American Institute of Biological Sciences Symposium in Davis, California (Lawrence 1988).

## Phytoplankton Modeling

This project integrated remotely sensed digital imagery of South San Francisco Bay (SSFB), California, into a numerical model of seasonal and spatial phytoplankton dynamics. The model was initially developed during a joint project with the USGS Water Resources Division in Menlo Park, California. The specific objectives of this project are to (1) modify and refine model coefficients of transport and phytoplankton production in SSFB by using both historical shipboard data and remotely sensed ocean color data; (2) validate model output with digital maps of near-surface chlorophyll concentrations derived from remotely sensed data; and (3) develop ELAS modules to process and analyze remotely sensed ocean color imagery.

The numerical model of SSFB follows the finite-difference box model approach described by Officer (1980) and Officer and Nichols (1980). The SSFB box model is a three-dimensional model containing both two-layer and lateral flow; the geometry of the boxes represents the average bathymetry at mean lower low water. Simulation parameters were calibrated using shipboard data acquired by the USGS during 1980 (Cloern 1984; Alpine and Cloern 1988). During 1988 the SSFB box model was transported to the IBM PC environment and enhanced to provide an efficient user-interface

base on a windowing environment, fast execution, rapid modification of simulation parameters, efficient storage and analysis of model output, and incorporation of different aquatic systems as simulation environments. These improvements have established this model for the Science and Technology Laboratory as a generic modeling tool that can be applied to various aquatic systems.

Nine AOCI, six CZCS, and six TM Simulator digital images of South San Francisco Bay have been acquired. All images have been reformatted for processing within ELAS. Because the spectral and spatial characteristics of the AOCI were designed specifically for ocean color analysis, our major effort has been to process and analyze the AOCI imagery. To date, each scene has been calibrated and georeferenced for co-location with field samples. We are still developing algorithms for atmospheric correction. In large part, these algorithms are based on the clear water concept used for affecting atmospheric correction of CZCS data. Our analysis of remotely sensed data has provided estimates of horizontal transport (vector displacement) and has indicated potential areas for the initiation and development of phytoplankton blooms.

The synoptic data of the CZCS and the AOCI suggest that the blooms originate over the southeastern shoals and migrate northward along the eastern shoals. We are developing programs to estimate horizontal transport through visible and thermal AOCI data. Model coefficients are being modified based on these results.

## Sediment Transport and Land Loss Processes

This project began in January 1989 and is a cooperative effort between the Stennis Space Center Space and Technology Laboratory, the Louisiana Geological Survey, and the Coastal Studies Institute of Louisiana State University. The project is designed to develop strategies and procedures for monitoring processes and responses associated with coastal zone land loss. Specific objectives are to (1) provide a synoptic monitoring capability; (2) develop a data base with remotely sensed data, together with analyses procedures suitable for long-range planning in the coastal zone; and (3) develop an understanding of the links between process and response, particularly with regard to hydrology/sediment transport, so that a set of predictive models can be generated.

An October 1989 overflight of CAMS over the Mississippi River Delta, Terrebonne Bay, and the Atchafalaya Bay in Louisiana, provided the initial data set in which to meet the project objectives. A coordinated field-sampling program consisted of ship surveys at all three sites. Continuous surface profiles of in vivo fluorescence, suspended sediments, temperature, and salinity were obtained using a flow-through system aboard the R/V *Pelican*. In addition to all flow-through instruments, other instruments interfaced to a micro-computer collected continuous samples of ship position and solar irradiance for continuous data collection and archiving. The digital imagery has been georeferenced and coregistered to produce large-scale mosaics of the study area. Data analysis of both field and remotely sensed data is underway.

## Mississippi River Plume and Oceanographic Processes

The primary objectives of this research are to (1) evaluate the information content of ocean color imagery acquired from CAMS and assess its potential for estimating surface chlorophyll concentrations, suspended sediment concentrations, and elements of water quality (and develop atmospheric correction and bio-optical algorithms); (2) investigate on a large spatial scale the biological responses to riverine inputs of organic materials, dissolved nutrients, sediments, and fresh water associated with the Mississippi River plume during both high and low river discharge; (3) investigate on small spatial scales, both horizontally and vertically, in a cross-plume direction, the roles of oceanographic fronts, discontinuities, and boundaries; and 4) examine the biological responses to the passages of meteorological fronts. This research will provide remotely sensed ocean color imagery to complement the Louisiana Stimulus for Excellence in Research Project (LaSER).

On 9 September 1989, the LaSER project flew a successful CAMS mission. Five flightlines provided complete coverage of the Mississippi plume. This imagery offers large gradients of chlorophyll pigments, suspended sediments, and dissolved organic and inorganic constituents for developing comprehensive algorithms. During the overflight, the R/V *Pelican* collected continuous surface profiles of in vivo fluorescence, nephelometry, temperature, salinity, solar irradiance, and plant nutrients with a near-surface flow-through system

interfaced to an on-board computer. Numerous discrete samples were collected for sensor calibration. These data are being processed and analyzed for incorporation into algorithm development of the CAMS digital imagery. Several programs were developed for NASA's ELAS image processing environment to calibrate and georeference CAMS data. The georeference software is of special note in that it provides for efficient and accurate georeferencing of aircraft data without the need for numerous control or "tie" points. The CAMS data collected have been reformatted for processing within ELAS, calibrated to yield spectral radiance, and georeferenced to latitude and longitude earth coordinates. The data are currently being processed to yield spatial maps of near-surface chlorophyll pigments and suspended sediments.

## Side-scan Sonar

Geologists have greatly benefited from the parallel development of earth-viewing remote-sensing instruments and comprehensive image processing techniques. Airborne platforms or satellite platforms routinely provide data to investigators to formulate complex spectral analyses over large spatial scales. Until recently, this technology was unavailable to marine geoscientists. The Geological Long-Range Inclined ASDIC (GLORIA) II side-scan sonar system is an acoustic imaging system capable of mapping the sea floor and providing data for geophysical, geological, and oceanographic investigations. However, as a prerequisite to extracting information from an image for data analysis, various geometric and radiometric distortions must be corrected. A collaborative effort exists between NASA/Science Technology Laboratory and the Geodynamics Research Institute at Texas A&M University to develop image processing software for processing and analyzing digital images acquired with long-range side-scan sonars. This project will focus primarily on data obtained from TAMU<sup>2</sup>, a state-of-the-art multifrequency side-scan sonar system under development at the Geodynamics Research Institute. Presently, software is being developed to preprocess and analyze data acquired from the GLORIA II and SeaMARC II systems.

In 1983, the United States declared sovereign rights over 200 nautical miles seaward from its shore. In 1984, the Institute of Oceanographic Sciences and the USGS conducted surveys of the so-called Exclusive Economic Zone (EEZ) off the

western United States (EEZ-SCAN 84). Four sonographs acquired during the EEZ-SCAN 84 survey off central California were used to develop a series of computer program modules to process GLORIA II data within NASA's ELAS image processing environment. These modules provide multibyte preprocessing techniques to reformat GLORIA images and to correct for geometric and radiometric distortions, including water column offset, slant range geometry, cross-track power drop off, multiple returns, speckle noise, striping, and anamorphic ratio. In addition to these modules, which are specific to GLORIA II data, ELAS contains a comprehensive set of general image processing procedures to provide an investigator with a consistent and powerful environment in which to fully process and analyze GLORIA II data.

## Acknowledgments

The research discussed in this paper was made possible through funds provided by the Earth Science and Applications Division and the Life Sciences Division of the NASA Office of Space Sciences and Applications, the NASA Office of Equal Opportunity Programs, and the NASA-SSC Director's Discretionary Program.

## References

- Bartlett, D. S., K. B. Bartlett, J. M. Hartman, R. C. Harriss, D. I. Sebacher, R. P. Travis, D. D. Dow, and D. P. Brannon. 1989. Methane emissions from the Florida Everglades: patterns of variability in a regional wetland ecosystem. *Global Biochem. Cycles* 3(4):363-374.
- Cloern, J. E. 1984. Temporal dynamics and ecological significance of salinity stratification in an estuary (South San Francisco Bay, USA). *Oceanol. Acta*, Vol. 7, pp. 137-141.
- Dow, D. D., J. A. Browder, and A. L. Frick. 1989. Modeling the effects of coastal wetland change on marine resources. Pages 221-227 in K. Mutz, ed. *Proceedings of the eighth annual Society of Wetland Scientists meeting*, 26-29 May 1989, Seattle, Wash.
- Dow, D., R. Pelletier, C. Clark, D. Brannon, and L. Gunderson. 1987. Remote sensing of the Florida Everglades conducted in support of the methane flux study. Pages 326-328 in *Proceedings of the space life sciences symposium on three decades of life science research in space*, 21-26 June 1987, Universities Space Research Association, Washington, D.C.
- Hansen, J., G. Russell, A. Laces, I. Fung, and D. Rind. 1985. Climate response times: dependence on climate sensitivity and ocean mixing. *Science* 229:857-859.

- Lawrence, W. T. 1988. Spectral characteristics of the foliage of tropical vegetation. *Bull. Ecol. Soc. Am.* 69(2):204.
- Officer, C. B. 1980. Box models revisited. Pages 65-113 in P. Hamilton, ed. *Wetlands and estuarine processes and water quality modeling*. Plenum Publishing Corporation, New York.
- Officer, C. B., and M. M. Nichols. 1980. Pages 329-340 in *Box model application to a study of suspended sediment distributions and fluxes in partially mixed estuaries*. *Estuarine Perspectives*.
- Pelletier, R. E. 1987. A predictive model to monitor temporal and spatial changes in marsh landscape features in the Barataria Basin. *Proceedings of the ninth biennial International Estuarine Research Federation conference*, 25-29 October 1987, New Orleans, La. [abstract]
- Pelletier, R. E., and D. D. Dow. 1987. A gridding approach to detect patterns of change in coastal wetlands from digital data. Pages 119-128 in *Proceedings of the technical papers of the American Society of Programmatic Remote Sensing*, 4-9 October 1987, Reno, Nev.
- Pelletier, R. E., and D. D. Dow. 1989. Monitoring the inundation of the Florida Everglades with AVHRR data in a geographic information system. Pages 266-275 in *Proceedings of the technical papers of the American Society of Programmatic Remote Sensing*, 2-7 April 1989, Baltimore, Md.
- Pelletier, R. E., and S. T. Wu. 1989. A preliminary evaluation of the Airborne Electromagnetic Bathymetry System for characterization of coastal sediments and marsh soils. Pages 366-375 in *Proceedings of the technical papers of the American Society of Programmatic Remote Sensing*, 2-7 April 1989, Baltimore, Md.
- Rickman, D. L., M. C. Ochoa, and K. W. Holladay. 1988. Multitemporal CAMS over coastal Louisiana: a problem in automated georeferencing. Pages 258-267 in *Proceedings of the second Forest Service remote sensing conference*, American Society of Photogrammatic Remote Sensing, 11-15 April 1988, Stennis Space Center, Miss.
- Roberts, H. H., O. K. Huh, S. A. Husu, L. J. Rouse, and D. L. Rickman. 1987. Impact of cold-front passages on geomorphic evolution and sediment dynamics of the complex Louisiana coast. *Coastal sediments '87*, WW Division of the American Society of Civil Engineers, New Orleans, La. 12-14 May 1987, Tech. Rep. 463.
- Walters, R. A., R. T. Cheng, and T. J. Conomos. 1985. Time scales of circulation and mixing processes of San Francisco Bay waters. *Hydrobiologia* 129:13-36.

# Enhanced Environmental Sensitivity Index Mapping Using Remote Sensing and Geographic Information System Technology

by

Bruce A. Davis

*Science and Technology Laboratory  
National Aeronautic and Space Administration  
Stennis Space Center, Mississippi 39529*

John R. Jensen and Elijah W. Ramsey, III

*Department of Geography  
University of South Carolina  
Columbia, South Carolina 29208*

and

Jacqueline Michel

*RPI International, Inc.  
1200 Park Street  
Columbia, South Carolina 29201*

**ABSTRACT.**—Environmental Sensitivity Index (ESI) maps are used to support oil spill response teams by providing information about the biological diversity of shorelines. In the event of an oil spill, these maps are taken into the field and used to determine where limited resources will be deployed to mitigate the effects of such a spill. RPI International, Inc. has been producing ESI maps for various geographic areas since 1979, and the company has produced more than 40 atlases. ESI maps are based on information gathered from several large oil spills throughout the world, including the Amoco Cadiz, Burmah Agate, Urquiola, and Metula. As a response tool, ESI maps must contain current information and convey that information in a meaningful manner to the response team.

Four types of information are associated with each ESI map sheet: planimetric base map, shoreline sensitivity index, oil-sensitive wildlife, and access and protection features. Base map construction for ESI maps typically relies on the United States Geological Survey's (USGS) 7.5- or 15-min topographic quadrangle map series. Biological data and shoreline type are manually drawn on mylar overlays, and the product is photographically reproduced. Shoreline sensitivity index data describe environment types that have varying degrees of sensitivity to oil or other pollutants. Oil-sensitive wildlife data are indicated by a symbol representing the species and a line transecting the extent of the species habitat. These symbols carry a wealth of wildlife information, including seasonal patterns, special status (endangered or threatened), and species name. Access and protection features are noted through the use of icons that identify existing marinas, boat ramps, booms, oil skimmers, and so forth, used during and after an oil spill.

Through the Earth Observation and Commercial Application Program, the Science and Technology Laboratory at the National Aeronautic and Space Administration's (NASA) Stennis Space Center and

the Department of Geography at the University of South Carolina are investigating the development of ESI maps through the use of remote sensing and geographic information system (GIS) technologies. The incorporation of these technologies will enhance ESI through the solution of three major problems.

First, adequate base map information is not always available for coastal areas covered by mangroves and other vegetation. When maps do exist they generally are not current and may not be at the desired scale. Remote sensing offers the advantage of routine data acquisition on a temporal basis adequate for most mapping needs in dynamic environments.

Second, land cover analysis in tropical areas carried out by boat or plane can lead to inaccurate results. Remote sensing can provide detailed information of land cover through the use of digital image processing and manual image analysis of satellite acquired imagery.

Third, portrayal of oil-sensitive wildlife information is difficult in ESI map development. This information can be understood more easily if presented as a single layer in a multivariate data base within a GIS. This would allow spill response managers to query complex data and derive clear and concise information in map form.

The focus to date in this project has been to replicate the proven ESI map product using remotely sensed data. SPOT Image Corporation panchromatic data have been used to develop a current base map. Geometric rectification of these data resulted in a base map product that has a  $\pm 5$  m root mean square error. This meets most national mapping accuracies for mapping at the 1:24,000 scale. The updated base map adds substantially to the value of the ESI map because of the improvement in the description of the transportation network.

Classification of land cover using remotely sensed data meets or exceeds ESI requirements. Red, black, and mixed mangrove classes were mapped in a region surrounding Marco Island, Florida, with both SPOT panchromatic and multispectral data in a merged format ( $10 \times 10$  spatial resolution). Furthermore, tidal flats, sand, water, and urban areas were classified to a Level I description with SPOT data. Classification accuracies for all land cover classes exceeded 85% with the satellite digital data. For areas in which confusion of multispectral data resulted in poor classification, the image analyst used interactive on-screen digitizing to classify the imagery. This was incorporated into the overall classification for use in the shoreline sensitivity rating.

From the classified satellite digital data it was possible to develop a shoreline sensitivity index by using a spatial search technique to construct a two-pixels-wide ribbon around each land use category. The results of the spatial search were then overlaid on the digital panchromatic base map. This process resulted in a color-coded symbol that was placed adjacent to the shoreline feature shown on the base map. The final product closely resembles the ESI map developed with conventional methods. However, the information in the digital product is current, and the ability to update to meet changing conditions in a timely and cost-effective manner is built into the map.

Future work in this project will concentrate on developing the data base aspect of the ESI map. The use of icons and "hot keys" to query the data base will improve the usability of ESI maps. These icons link to a data base containing important information, such as the number of skimmers or type of launch ramps at a marina.

Much more work is required before the ESI map is fully automated. However, current results show that incorporation of remote sensing and GIS technologies can produce accurate and current ESI maps showing shoreline sensitivity.

---

# Wetland Mapping Supported by the U.S. Environmental Protection Agency

by

John R. Maxted<sup>1</sup>

*Office of Wetlands Protection  
U.S. Environmental Protection Agency  
A-104F  
401 M Street, S.W.  
Washington, D.C. 20460*

**ABSTRACT.**—Wetland mapping is supported by the U.S. Environmental Protection Agency (EPA) through the Section 404 and Superfund programs. There are two basic types of wetlands mapping activities under these programs; comprehensive planning activities under the 404 program referred to as "advance identification" (ADID) and specific studies of 404 enforcement and Superfund sites. ADID projects assess the locations, functions and values, and potential threats to wetlands within a prescribed area. ADID projects are generally conducted at the 1:24,000 scale or smaller (up to 1:250,000), over areas generally greater than 1,000 acres (and up to millions of acres), and use information sources ranging from high-resolution aerial photography to satellite imagery. Section 404 enforcement and Superfund mapping activities of specific sites are also supported by EPA. This mapping is conducted generally at scales of 1:24,000 or larger (down to 1:3,000), over areas generally less than 1,000 acres, and uses aerial photography as the information source. Technical capability for EPA wetland mapping is available primarily through the Office of Research and Development; limited capability is available through EPA's regional offices. EPA wetlands mapping activities rely, to a large extent, on the mapping conventions developed by the U.S. Fish and Wildlife Service's National Wetlands Inventory (NWI) program, and in most cases directly use NWI maps and NWI mapping capabilities.

Our understanding of the importance of wetlands and the effects of both natural and anthropogenic influences on the Nation's wetlands resources has increased tremendously over just the last 30 years. The U.S. Fish and Wildlife Service (FWS) has played a leadership role in the classification of wetlands (Cowardin et al. 1979), the assessment of functions and values (Sather 1984), and the assessment of the causes and rate of wetland losses (Tiner 1984). In just the last 5 years, EPA has developed a fully operational wetlands research program to complement research programs within the FWS and the U.S. Army Corps of Engineers (COE). Most recently, added atten-

tion has been given to the need to protect the remaining wetland resources in the United States through the completion of the final report of the National Wetlands Policy Forum (The Conservation Foundation and the National Wetlands Policy Forum 1988) and the adoption of the Forum's recommendation of no net loss of wetlands by President Bush. The U.S. Environmental Protection Agency's (EPA) role in wetlands mapping within the Section 404 and Superfund programs has increased over the last several years as our scientific understanding of wetlands and public support for wetlands protection have increased.

## *Section 404*

Since its introduction in the Federal Water Pollution Control Act of 1972 (Clean Water Act), Section 404 has grown to be a major program within EPA; the program presently includes about 120

<sup>1</sup> Present address: State of Delaware, Department of Natural Resources and Environmental Control, Division of Water Resources, Watershed Assessment Branch, 89 Kings Highway, P. O. Box 1401, Dover, Del. 19903.



full-time employees in the regions and headquarters. EPA's primary role under Section 404 is to review permits issued by COE for the discharge of dredge and fill material into waters of the United States. The scope of the program has evolved from one that covered only navigable waters in 1972 to the current program that applies to all waters of the United States. The current Federal definition of "waters of the United States" is contained in several Federal regulations, including those developed for the National Pollution Discharge Elimination System (40 CFR, Part 122.2) and the Section 404 program (33 CFR, Part 328; 40 CFR, Parts 230.3 and 232.2). These regulations also include specific definitions of wetlands. Wetlands mapping supported by EPA has grown as the scope of the Section 404 program has grown.

The 1987 Amendments to the Clean Water Act give EPA and COE joint authority to enforce the requirements of Section 404. Section 309 provides a variety of enforcement mechanisms, including the authority to require violators to stop discharge activities and to seek civil and monetary penalties and prison sentences for violators. This enforcement authority requires EPA to generate evidence of violations to be presented in court. Violations often are detected from aerial photographs. Therefore, as EPA's authority to enforce the provisions of Section 404 has increased, so too has EPA's capability to map wetlands subject to illegal fill activities. EPA recently developed a general overview document that describes the enforcement and other elements of the Section 404 program (EPA 1989a).

### *Superfund*

The Comprehensive Environmental Response, Compensation and Liability Act (CERCLA) of 1980 and the Superfund Amendments and Reauthorization Act of 1986 give EPA the responsibility for managing the cleanup of hazardous waste sites in the United States. Mapping of a site, including the delineation of wetlands, is often used in remediation to document the extent of contamination and the parties responsible for the cleanup. If a responsible party cannot be identified, wetlands mapping may be completed to define cleanup goals. Such delineations are done by using present and historical aerial photography.

Currently, 1,165 sites are on EPA's national priority list (NPL). This list is used to rank the expenditure of Federal funds appropriated under CERCLA. Magistro et al. (1989) reported that,

based on the evaluation of 291 NPL sites, 62.5% are within 2 miles of wetlands, and 32.6% are in wetlands themselves. The EPA Office of Emergency and Remedial Response is responsible for administering the Superfund program and has also developed similar information documenting the proximity of NPL sites to wetlands. This information supports the continued development of wetlands mapping capability by EPA's Superfund program.

## Objectives

I describe two types of wetland mapping supported by EPA: mapping to support the comprehensive planning of wetland resources, referred to as "advance identification" (ADID); and mapping of specific Section 404 enforcement and Superfund sites.

### Advance Identification Mapping

Section 230.80 of the Section 404(b)(1) guidelines (45 *Federal Register* 85336, 24 December 1980) provides for EPA and COE to jointly evaluate potential disposal sites within a prescribed area, a process referred to as ADID. EPA has prepared draft guidance on the methods of conducting ADID projects (EPA 1989b); the draft includes a list and description of all ADID projects completed or proposed to date. ADID identifies, in advance of activities (i.e., development), wetlands suitable for fill and wetlands unsuitable for fill. This planning approach is designed to direct development away from the most valuable wetlands, thereby reducing conflicts between affected parties. The following lists the basic characteristics of ADID's:

- Jointly administered by EPA and COE. The project must have the involvement and endorsement of both organizations to be called ADID.
- Provides regulatory predictability to a broad range of interests—government, development, environment, and the general public.
- ADID provides information and advice. ADID results are not regulatory; that is, wetlands suitable for fill will not necessarily receive a Section 404 permit and wetlands unsuitable for fill will not necessarily be denied a Section 404 permit.

- ADID's are used to support many regulatory activities under the Section 404 program (e.g., permits, enforcement, and mitigation.)

Many other benefits can result from completed ADID's. For example, ADID's provide a basis for the development of wetlands protection programs at the Federal, State, or local levels of government, the acquisition of priority wetlands by government and private organizations, and the development of public education programs.

There are several steps in the ADID process; these steps are described in detail in the EPA guidance draft mentioned previously. The first step is the selection of the site to be evaluated. Ecological, threat potential, and political factors are used to select the size and specific boundaries of the ADID project. Next, the goals of the ADID are selected. The goal may be to support regulatory activities (i.e., Section 404 permitting), State and local program development, or public outreach and education. In most cases, ADID projects include a regulatory-based goal. Interagency coordination and public participation are the next steps in the process. In this step, EPA and COE issue a public notice before beginning the ADID. (Government agencies and the public are also informed of interim and final results.) Finally, the wetlands within the site are mapped, their functions and values defined, and suitable or unsuitable determinations completed.

No hard and fast criteria exist for determining whether a particular wetland is suitable or unsuitable for fill. General criteria are included in the EPA guidance draft, and include those criteria contained in the Section 404 program guidelines (45 *Federal Register* 85336, 24 December 1980). The delineation of wetland areas and the assessment of their functions and values provide the technical basis for this determination.

As of March 1989, there were 58 ADID projects either completed, underway, or proposed for start-up. Table 1 provides a breakdown of these projects by EPA regional office. A size distribution for 36 ADID projects summarized in Appendix C of the ADID guidance draft is listed in Table 2.

### *Mapping*

The mapping of wetlands for ADID projects provides the basis for assessing wetland functions and values and the determination of areas suitable or unsuitable for fill. National Wetlands Inventory (NWI) maps from the FWS, where available, pro-

vide the basis for the mapping conducted under ADID. Most ADID projects use the mapping conventions developed for the NWI program. In many instances, ADID funding is used directly to generate new NWI maps or to update existing maps. Consequently, map scales are generally 1:24,000, and wetland types are classified according to the Cowardin et al. (1979) system used in the NWI program.

The map products developed in ADID projects consist of two basic types: NWI maps and aerial photographs. In both instances, the wetland types developed with NWI mapping conventions are used to designate wetland areas either suitable or unsuitable for fill. In some instances, the final map product omits the detailed wetland classification information and only includes the designations of wetlands suitable or unsuitable for fill.

### *Summary of Projects: EPA Region 4 (Atlanta)*

Detailed information on all of the ongoing or planned ADID projects could not be collected in time for presentation at the NOAA workgroup symposium. The following summary of ADID projects in Region 4 is presented to illustrate the variety of wetland mapping activities supported by the ADID process. Appendix A is a map of the nine ADID projects currently underway or proposed in EPA Region 4 (southeastern United States). Appendix B provides a breakdown of information on each project with regard to funding, the group responsible for the mapping, the status of NWI mapping, and the type of photography used.

As shown in Appendix B, most projects use NWI maps as the baseline map product, with the exception of the Carolina Bays project, which will use wetland maps produced by the State. In some cases, existing NWI maps are used directly, whereas at other times, new or updated NWI maps are generated. Two basic mechanisms exist for producing new or updated maps: (1) the use of interagency agreements or grants to other agencies, including the FWS, State agency, and one local government; and (2) the use of in-house technical staff within EPA. Two of the largest ADID's, Pocosins in North Carolina and Carolina Bays in South Carolina, will use existing wetland maps. Most new mapping activities will use National High Altitude Photography as the base photos. Two projects include the digitization of the wetland mapping information. The Mobile Bay Area ADID is unique in that the study includes the comparison between NWI maps

Table 1. Number and status of advance identifications completed, currently under way, or proposed as of March 1989. Map shows geographic area of each region.

REGION	COMPLETED	CURRENT	PROPOSED	TOTAL
I	1	2	0	3
II	0	1	1	2
III	5	4	0	9
IV	0	3	6	9
V	5	6	1	12
VI	1	3	2	6
VII	0	2	1	3
VIII	0	2	2	4
IX	0	0	1	1
X	2	7	0	9
<b>TOTALS</b>	<b>14</b>	<b>30</b>	<b>14</b>	<b>58</b>

## EPA REGIONAL OFFICES

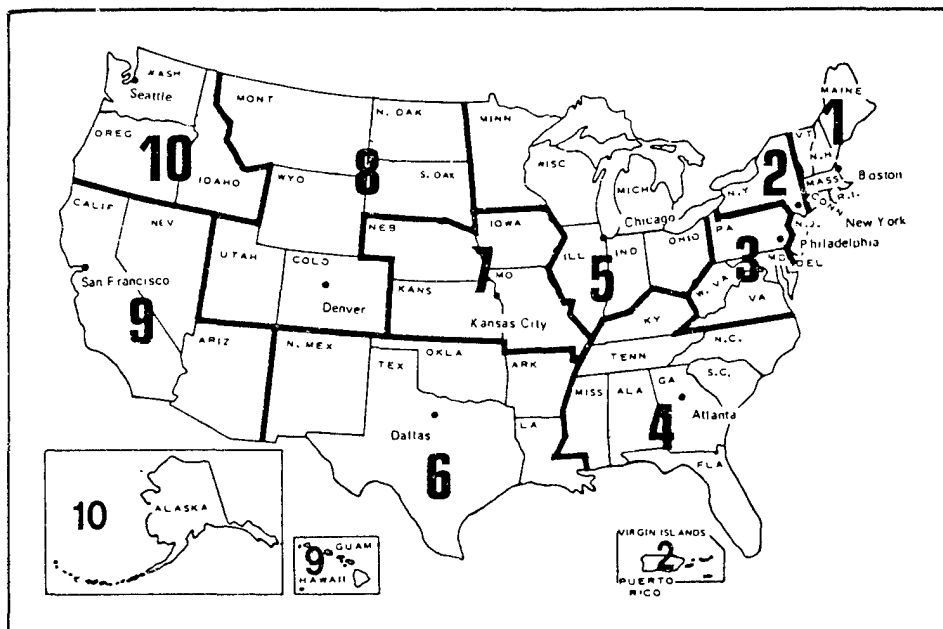

Table 2. *Size distribution for 36 advance identification (ADID) projects.*

Number of ADID Projects	Percent	Size
4	11	More than 1 million acres (largest 3.5 million)
10	28	100,000 to 1 million acres
13	36	10,000 to 100,000 acres
7	20	1,000 to 10,000 acres
2	5	Fewer than 1,000 acres (smallest 50 acres)

and computer-generated maps based on aerial photography and ERDAS software.

EPA funding supporting ADID projects in fiscal year 1990 is about \$250,000. It is not possible to estimate the proportion of this funding that specifically supports wetland mapping.

### *Perspectives for the Workgroup*

The level of activity involving wetland mapping under ADID has increased over the last few years and is expected to increase in the future. Before 1987, five ADID projects covered hundreds to thousands of acres. Between 1988 and 1989, 58 projects covered tens of thousands to millions of acres. This growth is due to additional EPA funding for ADID activities from EPA's Section 404 program.

ADID relies on NWI maps for documentation, and in some instances directly supports the development of new or updated NWI maps. NWI maps and the wetland classification system used in NWI provide a consistent basis for evaluations. Because the detailed classification is often not necessary in the final determination of wetlands suitable and unsuitable for fill, the final product often does not include such detail. This experience illustrates the utility of a standardized mapping protocol and map products developed by the Federal government. This is particularly important for assessing large areas that may cross State boundaries, where different protocols would create compatibility problems.

Mapping that is more detailed than NWI is usually not required. The 1:24,000 scale of NWI maps is an appropriate scale for most ADID's. For large areas covering parts of entire States, mapping at smaller scales (e.g., 1:100,000) is usually

required. If a smaller scale is necessary, the translation of the NWI information to the smaller scale is not labor- or time-intensive when compared with the generation of maps using other sources of information.

## **Site-specific Mapping—Section 404 Enforcement and Superfund**

EPA supports the mapping of wetlands on specific project sites identified as part of the Section 404 enforcement and Superfund program activities. Stokely (1987) summarized EPA remote-sensing support for Section 404 enforcement activities, and Norton and Prince (1985) summarized the use of remote sensing for wetlands assessment at Superfund sites. I do not discuss these two programs in detail. The reader is encouraged to review these documents and to contact the EPA program offices responsible for these two programs. The following is a general description of the procedures for conducting site-specific wetlands mapping under these two programs.

The determination of wetland boundary changes over time is the most important characteristic that distinguishes wetland mapping activities under these two programs from mapping conducted under ADID. In Section 404 enforcement, it is not as important to understand the functions and values of the wetlands as it is to precisely define the extent (acreage) of wetland loss, and wetland condition before an illegal activity occurred. This historical baseline condition is used in criminal prosecution and provides the goal for restoration of the site back to its original condition. Restoration often involves removal of the fill and some replanting of native wetland plants. In Superfund, historical information also is important to define the extent of impact, support the identification of parties responsible for the cleanup, and to define cleanup goals. The delineation of wetland boundaries and how these boundaries have changed over time because of human activity is the primary objective for wetland mapping conducted under both programs.

The present and historical data collected include wetland boundary delineation, vegetation cover type, and physical parameters. This information is often easily detected from aerial photographs. Because aerial photographs are often available as far back as the 1930's, they provide the necessary historical baseline information.

Consequently, aerial photography has been a powerful tool for both the Section 404 enforcement and Superfund programs.

### *Mapping*

Generally, the sites evaluated under these two programs are have fewer than 1,000 acres, and most often fewer than 100 acres. Because the area is relatively small, and the need for both accurate and precise information is great because of legal actions and liability determinations, mapping done under these programs is often at larger scales than the 1:24,000 scale used by the NWI. In instances where up-to-date NWI mapping is available, the NWI maps are often used directly, although even then new photography is often taken on lower-altitude flights to more precisely define wetland boundaries.

The mapping conducted under these programs relies on the mapping conventions developed by NWI. Legal actions and liability determination related to these programs benefit from the widely accepted system of delineation and classification provided by NWI. The map products developed for court cases under both the Section 404 enforcement and Superfund programs are generally aerial photographs with overlays. Photos provide an element of reality that is needed in the courtroom proceedings, and the small site area often lends itself to presentation on an aerial photograph. Map or photo scales are often in the range of 1:3,000 to 1:24,000. The classification of wetlands is based on Cowardin et al. (1979) or a more simplified scheme derived from Cowardin et al.

No detailed estimate has been developed of EPA funding for wetland mapping under Section 404 enforcement and Superfund; a rough estimate for the Section 404 program is under \$100,000 per year.

### *Perspectives for the Workgroup*

The level of enforcement and Superfund activity related to wetland mapping will increase as these two program continue to develop.

Map scales are often larger than NWI scales, and NWI provides a consistent protocol for developing these more detailed wetland maps. However, because these assessments cover relatively small areas, these maps are often not used to directly support the development of NWI maps. Similar to ADID, the mapping done under these two pro-

grams relies heavily on the standardized mapping provided by the Federal NWI program.

## **Support Services from the Office of Research and Development**

EPA's primary source of original wetlands mapping services is located within the Office of Research and Development. The Environmental Photographic Interpretation Center (EPIC) of the Environmental Monitoring Systems Lab-Las Vegas (a branch of the Advanced Monitoring Systems Division), supports many of EPA's regional wetlands mapping needs. For example, EPIC provided the wetlands mapping for EPA's pilot ADID for Chincoteague, Virginia, by using large-scale aerial photography (Norton 1986). EPIC supports Section 404 wetlands enforcement with special overflights, before and after documentation of illegal actions, chronological change analysis, courtroom displays, and expert testimony. For several years, EPIC has also produced chronological assessment map series of the wetlands around selected Superfund sites.

## **Conclusions**

EPA provides limited support for wetlands mapping under the Section 404 and Superfund programs. Most of these activities rely on the map conventions developed by FWS for the NWI program. The activities range from comprehensive planning covering thousands to millions of acres to site-specific assessments of areas less than 1,000 acres where mapping is needed to support legal actions. Consequently, a broad range of map scales is used. Wherever possible, the information available on the NWI 1:24,000-scale maps is directly used in EPA-supported wetland mapping. In many instances, particularly under the comprehensive planning program known as advance identification, EPA funding directly supports the development of NWI maps. EPA is one of many users of the FWS classification system, the NWI mapping protocol, and NWI maps. The close association in these activities between FWS and EPA illustrates the value of a coordinated Federal approach toward wetland mapping in the United States.

## Acknowledgments

I thank D. Norton of EPIC, and G. Vanderhoogt of EPA Region 4 for their assistance and guidance in preparing this paper.

## References

- Cowardin, L. M., V. Carter, F. C. Golet, and E. T. LaRoe. 1979. Classification of wetlands and deepwater habitats of the United States. U.S. Fish Wildl. Serv., FWS/OBS-79/31. 103 pp.
- Magistro, John L., L. C. Lee, and W. Ives. 1989. The relationship of Superfund sites to wetlands. 40 pp. [unpublished report]
- Norton, D. J. 1986. Suitability of Chincoteague wetlands for Section 404 activities. U.S. Environmental Protection Agency, Rep. TS-TIC-85037. Warrenton, Va. 19 pp.
- Norton, D. J., and J. Prince. 1985. Use of remote sensing for wetland assessment in hazardous waste sites. Proceedings of the nineteenth international symposium on remote sensing of the environment. Vol. II. 11 pp.
- Sather, J. H. 1984. An overview of major wetland functions and values. U.S. Fish Wildl. Serv., FWS/OBS-84/18. 68 pp.
- Stokely, P. M. 1987. The Environmental Protection Agency's remote sensing support of the Clean Water Act's Section 404 enforcement activity. 8 pp.
- The Conservation Foundation and the National Wetlands Policy Forum. 1988. Protecting America's wetlands: an action agenda. 69 pp.
- Tiner, R. W., Jr. 1984. Wetlands of the United States: current status and recent trends. U.S. Fish and Wildlife Service, National Wetlands Inventory, Washington, D.C. 59 pp.
- U.S. Environmental Protection Agency. 1989a. Highlights of Section 404. U.S. Environmental Protection Agency, Office of Wetlands Protection. 12 pp.
- U.S. Environmental Protection Agency. 1989b. Advance identification—guidance to EPA regional offices on the use of advance identification authorities under Section 404 of the Clean Water Act. U.S. Environmental Protection Agency, Office of Wetlands Protection. 60 pp. [draft report]

## Appendix A. Advanced Identification (ADID) Studies in Region IV

---

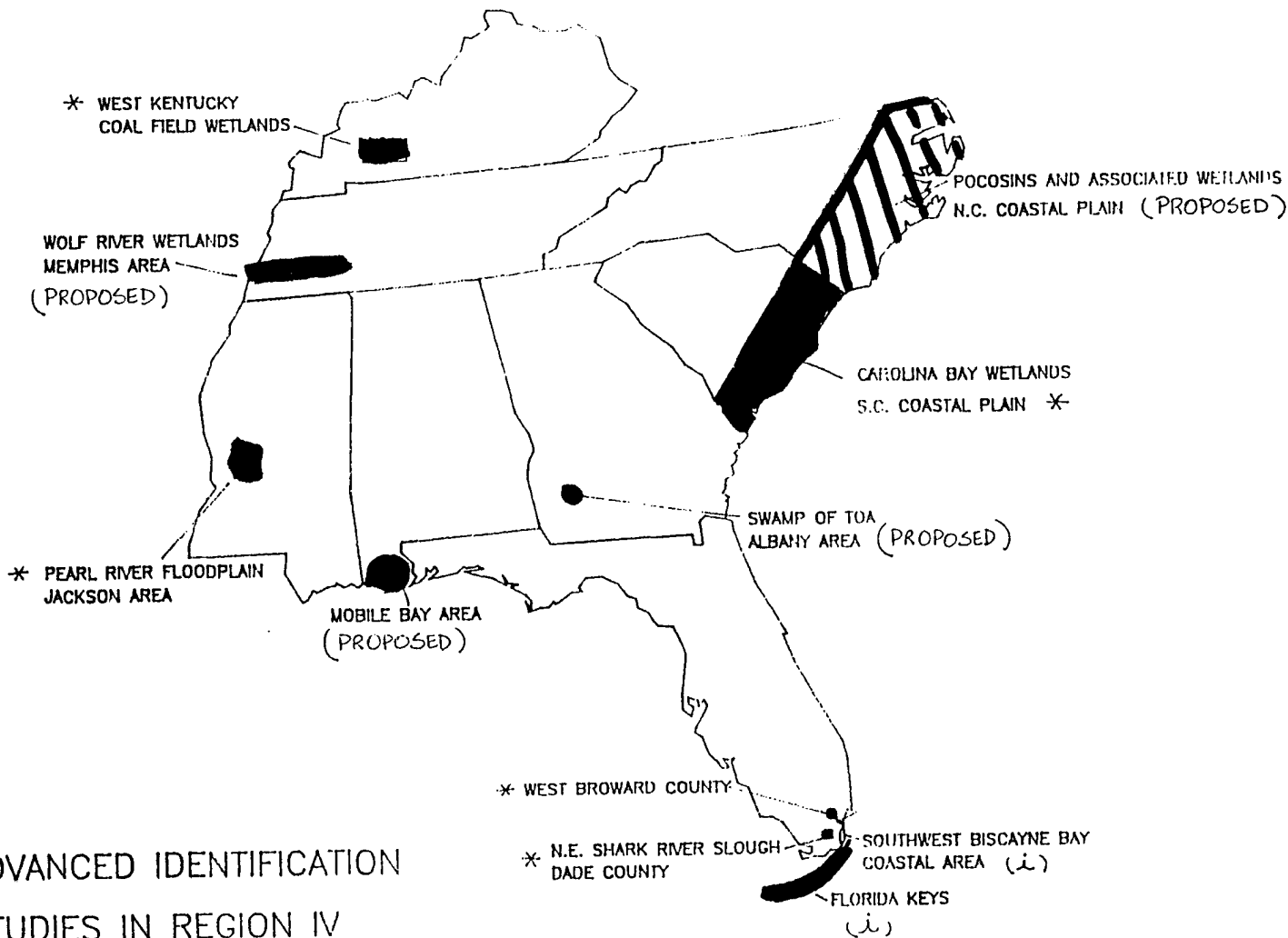

### ADVANCED IDENTIFICATION STUDIES IN REGION IV

- \* FIELD WORK UNDERWAY OR COMPLETED
- (i) INITIAL STAGES OF IMPLEMENTATION

(\* = fieldwork under way or completed).

## Appendix B. Costs Associated with Wetlands Mapping in Advanced Identification (ADID) Studies

---

### Costs Associated with Wetlands Mapping in ADID studies:

#### ADIDs using IAGs or Grants to other Agencies to perform mapping:

Pearl River/Jackson, MS:	
(No NWI maps for this study area)	
IAG w/FWS = \$37,000; Assume 2/3 for mapping	= \$24,666
NHAP photography	= 845
Digitization of maps	= 25,000
Total to map & digitize	= 50,511
Mobile Bay Area:	
(Existing NWI maps out-of-date.)	
IAG w/FWS to create new NWI maps for 24 quads = \$36,235/EPA & \$15,000/State	= 51,235
Digitization	= 20,000
Aerial Photos for ERDAS mapping	= 7,500
EPA personnel time to process in ERDAS	= 6,000
Kentucky Coalfield:	
(Using NWI maps as basis for mapping; NWI maps are based on most recent NHAPs)	
Grant to State = \$35,000; 1/2 for field verification/updating of NWI	= 17,500
USGS Topo maps	= 450
Southwest Biscayne Bay:	
Grant to Local Agency = 20,000; mapping	= 13,333
NHAP	= 2,000
(NWI maps out-of-date)	

#### ADIDs using in-house technical staff for mapping:

Northeast Shark River Slough:	
NHAP	= 1,100
staff time—4 weeks/GS 11	= 2,441
travel to study area	= 1,500
(NWI maps out-of-date)	
West Broward County:	
NHAP	= 1,100
staff time—6 weeks/GS 11	= 3,362
travel to study area	= 2,400
(NWI maps out-of-date)	
Swamp of Toa:	
NHAP	= 1,215
staff time—8 weeks/GS 11	= 4,882
travel to study area	= 2,000
(NWI maps out-of-date)	

#### ADIDs using existing wetlands maps (no new mapping):

Pocosins/N.C.—using existing NWI maps  
Carolina Bays of S.C.—using existing maps produced by the state



# U.S. Environmental Protection Agency's Environmental Monitoring and Assessment Program, an Ecological Status and Trends Program

by

John F. Paul

*U.S. Environmental Protection Agency  
Environmental Research Laboratory  
27 Tarzwell Drive  
Narragansett, Rhode Island 02882*

A. F. Holland

*Versar, Inc.  
9200 Rumsey Road  
Columbia, Maryland 20145*

Steven C. Schimmel

*U.S. Environmental Protection Agency  
Environmental Research Laboratory  
27 Tarzwell Drive  
Narragansett, Rhode Island 02882*

J. Kevin Summers

*U.S. Environmental Protection Agency  
Sabine Island  
Gulf Breeze, Florida 32561*

and

K. John Scott

*Science Application International Corporation  
27 Tarzwell Drive  
Narragansett, Rhode Island 02882*

**ABSTRACT.**—The U.S. Environmental Protection Agency (EPA) is initiating an Environmental Monitoring and Assessment Program (EMAP) to monitor the status and trends of the Nation's near-coastal waters, forests, freshwater wetlands, surface waters, agroecosystems, deserts, and rangelands. This program is also intended to evaluate the effectiveness of EPA policies in protecting the ecological resources of these systems. The monitoring data collected for all ecosystems will be integrated for national status and trends assessments. The near-coastal component of EMAP consists of four ecosystem categories: estuaries, wetlands, coastal waters, and the Great Lakes. The near-coastal ecosystems have

been regionalized and classified, an integrated sampling strategy has been designed, and quality-control procedures and data-base management designs will be implemented. A demonstration project will be conducted in the Virginian biogeographic province in 1990, followed by a full-scale national implementation. EMAP will characterize national ecological resources to establish a baseline for monitoring and assessment. The characterization strategy involves the application of remote-sensing technology to obtain high-resolution data on selected sample sites and lower resolution data over broad geographic areas.

The cost of environmental regulatory programs has been estimated at more than \$70 billion annually, yet the means to assess the long-range effects of these programs on the environment do not exist. While regulatory programs are based on our best understanding of the environment at the time of program development, it is critical to use long-term monitoring to confirm the effectiveness of these programs in achieving environmental goals, and to corroborate the science on which they are based.

The U.S. Environmental Protection Agency (EPA), the U.S. Congress, and private environmental organizations have long recognized the need to improve our ability to document the condition of the environment. Congressional hearings in 1984 on the Monitoring Improvement Act concluded that despite considerable expenditures on monitoring, Federal agencies could assess neither the status of ecological resources nor the overall progress toward legally mandated goals of mitigating or preventing adverse ecological effects. In the last decade, articles and editorials in professional journals of the environmental sciences have repeatedly called for the collection of more relevant and comparable ecological data and easy access to those data for the research community. The most commonly suggested tools for accomplishing these goals include a national ecological survey and a bureau of environmental statistics.

In 1988 the EPA Science Advisory Board, affirming the existence of a major gap in environmental data and recognizing the broad base of support for better environmental monitoring, recommended that EPA start a program that would monitor ecological status and trends and develop innovative methods for anticipating emerging problems before they reach crisis proportions. EPA was encouraged to become more active in ecological monitoring because its regulatory responsibilities require quantitative, scientific assessments of the complex effects of anthropogenic activities on ecosystems. The Environmental Monitoring and Assessment Program (EMAP) is EPA's response to these recommendations.

EPA's Office of Research and Development, in concert with several other Federal agencies, is

developing EMAP to determine the current status, extent, changes, and trends in the condition of the Nation's ecological resources. When fully implemented, EMAP will be able to respond to the following questions:

- What proportion of the Nation's ecological resources are degrading or improving, and where and at what rate?
- What are the likely causes of the observed degraded conditions?
- What is the current status, extent, and geographic distribution of our ecological resources?
- Are control and mitigation programs effective in maintaining or improving the quality of the resources?

## Objectives of the Environmental Monitoring and Assessment Program

To provide the information necessary to address the previous questions and the goal of the program, EMAP has the following objectives:

1. Estimate the current status, extent, changes, and trends in indicators of the Nation's ecological resources on a regional and national basis, with known confidence limits.
2. Monitor indicators of pollutant exposure and habitat condition, and seek correlative relations between anthropogenic stresses and ecological conditions that identify possible causes of adverse effects.
3. Provide periodic statistical summaries and interpretive reports on ecological status and trends to the EPA administrator and the public.

## EMAP Approach

Assessing whether the condition of the nation's ecological resources is improving or degrading requires ecological data on large geographic scales and over a long time. EMAP represents a different approach to monitoring than has been used by

EPA in the past. Specifically, the program is different in five aspects:

1. EMAP proposes to use a top-down ecosystem approach in determining appropriate parameters in the environment. The program proposes to monitor those things that relate most directly with ecosystem-level responses.

2. An integrated approach is used in the sense of being able to look across ecosystem types. For example, researchers not only want to determine the condition of estuaries, but also would like to determine the possible causes of adverse conditions that are observed. Scientists recognize that a lot of problems in estuaries are not due to activities that occur directly in the estuaries, but are due to anthropogenic activities in the terrestrial systems of our country. Estuaries are the downstream repository for the products of human activities, whether these products get there by aquatic routes or through the atmosphere.

3. A number of indicators will be used to determine ecological condition. A lot more information about the systems can be obtained by monitoring a group of parameters than by measuring a single parameter.

4. EMAP is envisioned as a long-term program within EPA. The concept of long-term within some parts of the agency is 3–6 months. Typical research programs in EPA generally last 3 years. In EMAP, however, long-term means decades. For example, to study the responses of ecological systems to regional-scale pollution control strategies (which in themselves take years to implement over an entire region) would take as much as a decade.

5. EPA is proposing to implement EMAP as a multiagency endeavor. For example, researchers in the near-coastal component of the program are working with NOAA's National Status and Trends Program to merge the two programs into a single Federal marine monitoring program. Also, EMAP is closely coordinating its wetlands activities with the U.S. Fish and Wildlife Service's (FWS) National Wetlands Inventory to ensure compatibility and to use the extensive expertise that already exists.

## EMAP Near-coastal Component

While the EPA's goal is to establish EMAP in all ecosystem types, its initial emphasis is on testing and implementing the program in the near-coastal estuarine and wetlands systems. The following approach is being used to develop and

design the monitoring program for the near-coastal component:

- Review and evaluate existing data on near-coastal ecosystems with respect to EMAP's objectives. It is not EPA's intention to develop a new program that disregards historical and ongoing monitoring activities. EMAP will use the wealth of information that has already been obtained on near-coastal ecosystems.
- Determine the pollution endpoints of concern that the program is to address, and then develop, evaluate, and standardize measures and indicators of conditions that relate to these endpoints. Some of these indicators can be implemented directly into the program, whereas others will require further research and evaluation before they can be implemented.
- Regionalize and classify near-coastal ecosystems as an objective way of grouping systems with similar attributes. Useful groupings are those that provide within-group variations that are less than those among groups. Because all ecosystems cannot be sampled, classification should aid extrapolation among systems within a class.
- Design a statistically unbiased, flexible, integrated sampling strategy for all near-coastal ecosystems that will be compatible with the EMAP inland ecosystem strategy (U.S. Environmental Protection Agency 1989). For the program to provide diagnostic capabilities (e.g., relate pollution problems with potential causes), the overall sampling strategy must be integrated with a compatible statistical design.
- Implement logistics, quality assurance and quality control, and data-base operations. These elements are the core of the program, and are necessary to meet EMAP's objectives.
- Conduct a demonstration project for estuaries in the Virginian biogeographic province (Cape Hatteras to Cape Cod) in 1990. This demonstration project will be used to design the full-scale national implementation portion of the program.
- Implement the full-scale national program.

## Near-coastal Endpoints of Concern

EPA clearly does not have resources to monitor all attributes of all near-coastal resources, or to

conduct research on all specific pollution problems that are likely to be identified as being of concern. Therefore, EMAP activities must focus on ecosystem attributes that are of utmost concern to society. These attributes are termed endpoints of concern, and each endpoint selected for monitoring should have a direct and easily recognized value to society. It may not always be possible to take a direct measurement of each of the selected endpoints. In some cases, it is necessary to measure variables, here termed indicators, that have characteristics reflective of the endpoints, but for which field data are more easily collected and interpreted. Measurements of indicators will be used as estimates of endpoints only if they are directly comparable to endpoint responses and are also typical of systemwide responses.

The endpoints of ecological status are clearly related to the public's use of the near-coastal ecosystems for commercial, recreational, and aesthetic purposes. A primary endpoint is the health of fish and shellfish populations. In other words, are fish and shellfish populations present in densities sufficient to make commercial and recreational harvesting feasible? Also, if the populations are abundant, are they free of disease and other manifestations of stress, and are they safe to eat? In short, a major endpoint of concern is the ability of the near-coastal water to support harvestable and contaminant-free fishery populations. While this endpoint refers to species of commercial or recreational importance, it is directly related to regulatory mandates to maintain naturally reproducing populations and communities of resource value or otherwise (Federal Water Pollution Control Act of 1972 and subsequent amendments, and Marine Protection, Research and Sanctuaries Act of 1972).

The second major endpoint of concern is the maintenance of near-coastal habitat structure. An example is the public concern for wetland loss and its subsequent effects on species and the functional value of wetlands as physical and chemical buffers between terrestrial and aquatic systems. Changes in the distribution and abundance of submerged aquatic vegetation (SAV) also have dramatic effects on the public's perception of environmental health. Any modification in habitat structure, whether it be the filling of a wetland, diversion of freshwater inflow, or the presence of noxious algal blooms, is correctly perceived as an environmental health problem.

These endpoints of ecological values may be affected by any number of anthropogenic or natural forces. For example, wetland loss and the subsequent declines of fishery nursery areas may be affected more severely by hurricanes and sea level rise than by shoreline development. EMAP researchers find it challenging to discriminate this type of effect. To do this, we selected indicators of endpoint condition that, when used in concert, would broadly identify the environmental impact. The major environmental problems addressed are:

- eutrophication, to include both primary and secondary productivity imbalances in the water column and benthos;
- toxic and pathogenic contamination of biological tissue, water column, and sediments;
- habitat modification, primarily oriented at wetlands and submerged aquatic vegetation;
- cumulative impacts resulting from the integrated effects of various categories of environmental stress; and
- emerging environmental problems, such as global climate change, unknown contaminants, overharvesting, and declining biodiversity.

## Indicators Selected for EMAP Near-coastal Component

The core indicators for the near-coastal component of EMAP are:

*Dissolved oxygen.* Hypoxic or anoxic conditions are a functional response of the system to primary production imbalances, which can result from nutrient and biochemical oxygen demand (BOD) loadings. Associated indicators are nutrient discharge and loadings data.

*Water clarity.* Algal blooms and high suspended loads can have significant effects on other system components. Transmissometry and fluorometry measurements will be made at least two times during the index period at each station. These measurements will be used in conjunction with the dissolved oxygen (DO) indicator.

*Benthic abundance, biomass, and species composition.* This indicator reflects the ability of the benthos to support bottom fish populations and the ability of the benthos to maintain the natural sediment processing features important to nutrient and contaminant flux. The condition of the benthic community is also an integrator of the

overall condition of the water body, and may respond to contaminants or to eutrophic conditions.

*Sediment toxicity.* The sediment toxicity indicator that uses amphipods is also an integrated measure that, in this case, is specific to contaminant exposure and effects.

*Sediment contaminants.* The selected suite of contaminants is a direct measure of exposure to this form of input, and will be related to responses of the benthic community and sediment toxicity.

*The number and abundance of fish species.* This indicator is a cumulative effect response indicator, which will respond to a host of anthropogenic and natural factors.

*Fish gross pathology.* This indicator is a response to contaminant exposure, and reflects on the marketability of the subject fish populations.

The core indicators just listed form the basic measurements we have proposed for the near-coastal component. All of these indicators will be evaluated during a 2-month, late summer index period, when biological responses to environmental perturbations are expected to be enhanced.

We propose to test a number of additional indicators during the 1990 demonstration project. These indicators are allocated to the research category.

*Wetlands and SAV acreage.* These indicators provide a direct measure of habitat modification and loss, and include wetland functional measures such as shape and boundary variables. The current measurement methods to describe these indicators have not yet demonstrated their utility. We also propose to test the feasibility of using wetlands data collected from satellite imagery.

*Remotely sensed chlorophyll and suspended solids.* Responses in the dissolved oxygen would indicate the need to identify prior imbalances in primary productivity. A posteriori examination of satellite images for selected systems would be assessed for sensitivity in selected low and high susceptibility classes.

*Water column toxicity.* The proposed chronic toxicity tests are integrated measures of water column exposure to contaminants. The tests will be related to shellfish growth and survival. These are our only indicators of water column contaminant exposure.

*Shellfish growth and survival.* The shellfish indicator represents a nonspecific response indicator that integrates the ability of the water body to support shellfish growth.

*Shellfish contaminants.* These contaminant measures are the same as for sediments and will serve as a direct measure of contaminant exposure. They will, however, only be used to explain changes in growth and survival.

*Sediment mixing depth.* This measurement is proposed because it is an indication of the functional activity of the benthos as related to sediment processing. The implication is that shallowly mixed sediments have less potential for contaminant flux than deeply mixed sediments.

*Biomarker responses.* Several biomarkers are proposed for testing, including DNA unwinding, phagocytic killing ability, micronucleus formation, and stress protein concentration.

In addition to the indicators just described, there are a number of stressor indicators used to enhance the interpretation of the indicator responses previously mentioned and to help describe possible causes of adverse conditions. These variables will be provided by other EMAP groups and Federal, regional, and State agencies. The stressor indicators include nutrient and contaminant loadings, land use patterns, incidence of fish kills and beach closures, loadings via atmospheric deposition, incidence and extent of fishery closures, census data, and commercial fishery landings.

## Regionalization and Classification

The near-coastal waters of the United States contain hundreds, perhaps thousands, of estuarine, tidal wetland, and coastal water ecosystems. It would be impractical for EMAP to measure the ecological conditions of all of these ecosystems. EPA's available resources allow only a subset of these ecosystems to be sampled. Extrapolation of monitoring results to unsampled systems will be difficult because the characteristics, functions, pollution exposure, and human uses of near-coastal environments vary among and within regions. Regionalization and classification paradigms provide an objective method for grouping ecosystems into categories based on sets of similar attributes (e.g., climate, geology, hydrology, currents, and biota). The regionalization scheme used in EMAP for near-coastal ecosystems is based on the primary climate provinces and major offshore ocean currents. We are using the 12 biogeographic provinces shown in the Figure, which are consistent with those published by NOAA (1990) and used by FWS (Cowardin et al. 1979).

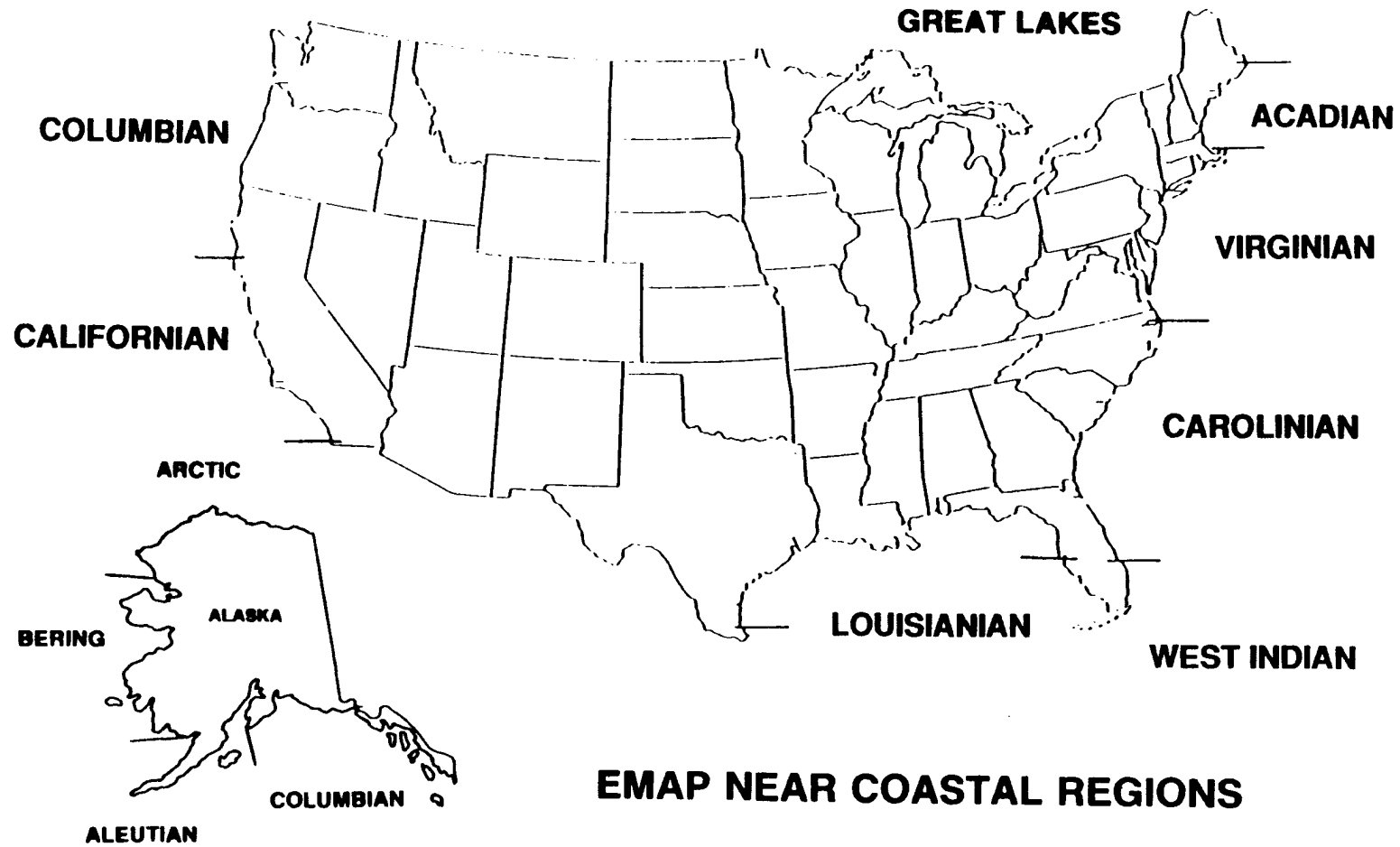

Figure. Biogeographical province used for near-coastal regionalization scheme in the Environmental Monitoring and Assessment Program (EMAP).

EMAP's basic classification system will group estuaries into three categories: large estuaries, large tidal rivers, and small estuaries. A 280-km<sup>2</sup> grid network is located over the region, by using a random start point to provide a systematic grid for selection of sampling locations in the large estuaries. The large tidal rivers are sampled by a linear analog of the design for the large estuaries. A systematic grid (or more appropriately, a line) is used to characterize the spine of these tidal rivers. A list frame of all of the remaining estuarine systems is created and used to select systems for sampling.

### Near-coastal Demonstration Project

An EMAP Near-coastal Demonstration Project was conducted in the Virginian biogeographic province during summer 1990. The project is designed to serve as a model for the implementation of EMAP in other ecosystems. The project has these major goals:

- Test and validate the utility of the EMAP Near-coastal Project indicators for making regional assessments.
- Assess the effectiveness of the sampling design for making regional estimates of ecological conditions.
- Identify and resolve logistical issues associated with implementing a national-scale monitoring program.
- Provide regional-scale information to refine the sampling design for full-scale implementation.
- Select indicators for use in full-scale implementation.

A report on the results of the demonstration project should be available in September 1991.

### Proposed Implementation Schedule

The proposed full-scale implementation of the EMAP Near-coastal Project will be a phased approach into all of the regions of the conterminous United States. The year prior to monitoring activities in any province will be used to plan and design the specifics for implementation. The first year of monitoring will be treated as a regional demonstration project to test and validate the indicators and design. The operational monitoring would start in the second year.

The proposed schedule for implementation of the demonstration projects was 1990 for the Virginian province, 1991 for the Louisianian province, 1993 for the Carolinian province, 1995 for the Californian and Columbian provinces, and 1994 for the Acadian and West Indian provinces.

Implementing the EMAP Near-coastal Project into Alaska, coastal waters, and the Great Lakes could proceed on a similar parallel track as resources become available.

### EMAP Landscape Characterization

National assessments of status and trends of the condition of ecosystems require knowing not only what percentage of a particular resource is in desirable or acceptable condition, but also how much of that resource exists. Some types of wetlands are being lost at an alarming rate; conversion and loss of other types of ecosystems are also occurring. Such changes may be of particular concern if causally correlated with pollutant exposure or other anthropogenic stresses. For most ecosystems, few national data bases can currently be used to derive quantitative estimates of ecosystem extent with known confidence.

Landscape characterization within EMAP is a description of landscape features (e.g., wetlands, forests, soils, land use, and urban areas) in areas associated with EMAP sampling sites. The characterization provides some of the stressor indicator information for the EMAP Near-coastal Project. Characterization uses remote-sensing technology (satellite imagery and aerial photography) and other techniques (e.g., cartographic analysis and analysis of census data) to quantify the extent and distribution of ecosystems. Over time, periodic aerial and satellite imagery will permit quantitative estimates of changes in landscape features that might be related to anthropogenic activities and pollutants.

The characterization strategy involves the application of remote-sensing technology to obtain high-resolution data on selected sample sites and lower-resolution data over broad geographic areas. Other data sources will be used to supplement remotely sensed data.

EMAP will assemble, manage, and update these data in geographic information system format. A standardized characterization approach and a landscape information network common to all ecosystems will be used to optimize cost and data

sharing, and to ensure common format and consistency. Through close work with other agencies, EMAP will establish design requirements for the integrated characterization, including acceptance criteria for baseline data, consistent classification detail and accuracy, and suitable spatial and temporal resolution to detect landscape features of particular interest.

The design of the characterization plan and the evaluation of potential characterization techniques are in progress. A prototype methodology for high-resolution characterization has been developed (Norton et al. 1989). EMAP characterization began in 1990 at about 100 sites.

### Acknowledgments

Although the work described in this article was supported by the U.S. Environmental Protection Agency, it has not been subjected to agency review and therefore does not necessarily reflect the

views of the agency; no official endorsement should be inferred.

### References

- Cowardin, L. M., V. Carter, F. C. Golet, and E. T. LaRoe. 1979. Classification of wetlands and deepwater habitats of the United States. U.S. Fish Wildl. Serv., FWS/OBS-79/31. 103 pp.
- National Oceanic and Atmospheric Administration. 1990. Title 15, Code of Federal Regulations, Chapter IX, Part 921—National Estuarine Sanctuary Program regulations.
- Norton, D. J., D. M. Muchoney, E. T. Slonecker, and J. H. Montanari, 1989. Landscape characterization for ecological monitoring. Rep. TS-PIC-89301. Environmental Monitoring Systems Laboratory, U.S. Environmental Protection Agency, Las Vegas, Nev. 42 pp.
- U.S. Environmental Protection Agency. 1989. Design report for the Environmental Monitoring and Assessment Program. U.S. Environmental Protection Agency, Environmental Research Laboratory, Corvallis, Oreg. 125 pp. [Draft report]



## Importance of Hydrologic Data for Interpreting Wetland Maps and Assessing Wetland Loss and Mitigation

by

Virginia Carter

*U.S. Geological Survey  
430 National Center  
Reston, Virginia 22092*

**ABSTRACT.**—The U.S. Geological Survey collects and disseminates, in written and digital formats, groundwater and surface-water information related to the tidal and nontidal wetlands of the United States. This information includes quantity, quality, and availability of groundwater and surface water; groundwater and surface-water interactions (recharge–discharge); groundwater flow; and the basic surface-water characteristics of streams, rivers, lakes, and wetlands. Water resources information in digital format can be used in geographic information systems (GIS's) for many purposes related to wetlands. U.S. Geological Survey wetland-related activities include collection of information important for assessing and mitigating coastal wetland loss and modification, hydrologic data collection and interpretation, GIS activities, identification of national trends in water quality and quantity, and process-oriented wetland research.

Wetlands are dynamic ecosystems whose existence, persistence, and function are controlled by hydrology. Hydrologic data are important for wetland map interpretation, trend assessment, impact prediction, site selection for mitigation and wetland research, and data-collection network design for both small- and large-scale studies. Wetland maps provide two-dimensional information on the location and classification of wetlands; this information needs to be supplemented with geologic and hydrologic information to provide the third dimension needed for wetland assessment.

As part of its mission, the U.S. Geological Survey (USGS) collects and disseminates, in reports and digital formats, groundwater and surface-water information related to the tidal and nontidal wetlands of the United States. This information includes quantity, quality, and availability of groundwater and surface water; groundwater and surface-water interactions (recharge–discharge); groundwater flow; and the basic surface-water characteristics of streams, rivers, lakes, and wetlands (e.g., sediment load, transport, and floodplain geomorphology). Hydrologic information in digital format can be used in geographic informa-

tion systems (GIS's) for many purposes related to wetlands.

Wetland studies are an integral part of the USGS's hydrologic activities, and USGS wetland projects have been conducted in a wide range of hydrogeologic settings throughout the United States. These projects include problem-oriented field investigations, data collection activities, and process-oriented research. The broad research and data collection capabilities of the USGS have resulted in significant contributions to the understanding of the role of hydrology in wetland functions and processes. The USGS Federal–State cooperative programs with Federal, State, and local agencies in all 50 States aid in maximum use of research results. In the following sections, I describe some of the wetland-related activities of the USGS.

### Coastal Wetland Loss or Modification

Louisiana has experienced significant recession of its shorelines accompanied by losses in coastal

wetlands in the Mississippi Delta during the last few decades. Under natural conditions and in the historic past, water overflowing from the Mississippi River at times of high river stage replenished the sediment on the wetland surface, resulting in a balance between accretion and subsidence. Recently constructed dikes along the lower Mississippi River now prevent the natural overflow of sediment-laden water onto coastal wetlands and thus contribute to the current wetland loss. Another strong contributory factor in the rapid recession of shorelines in the Mississippi Delta is the decrease in the supply of river sediment. Historically, the Missouri River basin has been the greatest supplier of sediment to the lower Mississippi River. Following the completion of five major dams for irrigation and hydroelectric power on the Missouri River from 1953 to 1963, the flow of sediment from the Missouri River basin virtually stopped (Meade and Parker 1985), decreasing the sediment load of the lower Mississippi River.

One of the suggested solutions for stopping, or at least slowing, the loss of coastal wetlands in Louisiana is the redirection of water from the lower Mississippi River. However, the diminished sediment load of the Mississippi River, as well as the river's burden of pollutants, must be considered in any program designed to divert water for stabilization of remaining wetlands in Louisiana. The USGS has an ongoing study on the Mississippi River (Meade 1989) to determine sediment loads and to characterize dissolved and sediment-transported contaminants. The portion of the river being studied begins near St Louis, Missouri, near the confluence of the Mississippi, the Missouri, and the Illinois rivers. The sampling plan is designed to represent variable levels of river stage and discharge. Fortunately, the sampling period has included the drought years of 1987-88. Depth-integrated samples from 10 to 40 verticals in each cross section are composited and subjected to detailed analysis for metals and selected organic compounds. Preliminary results show the presence of a variety of trace metals at nominal concentrations, and computations of loadings show that most metals are conservative throughout the system (Taylor et al. 1989). These findings are consistent with other studies on the lower Mississippi River. Although some organic pollutants are found only in certain tributaries, atrazine and other herbicides are ubiquitous throughout the entire Mississippi River system. Currently, 100 tons of atrazine per year, or 0.3%

of the entire annual U.S. atrazine production, is estimated to be carried by the Mississippi River to the Gulf of Mexico (Periera et al. 1989).

Coastal wetlands throughout the United States are threatened by rising sea levels. In particular, fresh and brackish tidal wetlands may be affected by intrusion of salt water. In addition to rising sea level, other factors that cause such intrusions may include storm surges; diversions of fresh water for industrial, agricultural, and municipal use; and extensive pumping of groundwater in the coastal plain. In the case of Hurricane Hugo, which struck the South Carolina coast on 21-22 September 1989, the USGS, in cooperation with the Federal Emergency Management Agency and the U.S. Army Corps of Engineers, is mapping the height and extent of the storm surge in South Carolina. Within 2 days after the storm hit, USGS staff were in the field locating and surveying the high-water marks. Maps showing the altitude of high water caused by the storm surge are being drawn and will be published early in 1990. A similar effort is occurring in Puerto Rico. Through the use of satellite telemetry, the USGS also monitors the extent of saltwater intrusion in South Carolina estuaries (Carswell et al. 1988), and even followed the intrusion resulting from Hurricane Hugo as it occurred. Information of this kind can be used to identify wetlands threatened by rising sea level or saltwater intrusion in order to assist agencies responsible for wetland protection and mitigation of storm- or salinity-related damage.

## Hydrologic Data Collection and Interpretation

The USGS summarizes water-resource information on many topics in a series of reports known as the National Water Summary (NWS). Present plans are for the 1992-93 NWS to be devoted to wetlands. This NWS will be the first to draw extensively on information from ongoing programs in other agencies doing major work in wetlands, including the U.S. Fish and Wildlife Service, the U.S. Environmental Protection Agency, the U.S. Army Corps of Engineers, the National Oceanic and Atmospheric Administration, and the U.S. Soil Conservation Service. The NWS will also report on USGS national and State activities in wetlands. Although the report is still in its early planning stages, the 1992-93 NWS will contain maps showing the distribution of wetlands on a State-by-State basis. The USGS also plans to work closely

with the U.S. Fish and Wildlife Service in producing and digitizing a national base map and wetland maps for each State and for Puerto Rico and the Trust Territories. A variety of wetland-related hydrologic data and the locations of data-location sites will be overlaid on the State and national base maps for the report.

The USGS is one of the many Federal, State, and local agencies cooperating with the Chesapeake Bay Program. The USGS is providing data on quantity and quality of water entering the Chesapeake Bay, and data on submersed macrophyte distribution and abundance in the tidal Potomac River and its estuary. These data will be incorporated into the Chesapeake Bay GIS and into models being developed for the bay and its tributaries. One of the major concerns of the Chesapeake Bay Program is the baywide decline in aquatic plant beds (wetlands containing submersed aquatic vegetation [SAV]) in recent years. Data on distribution and abundance of SAV in the Potomac River are being supplied to the Virginia Institute of Marine Science, which is presently conducting the baywide SAV monitoring and mapping program. These data are particularly important in light of the recent recovery of SAV in the freshwater tidal reach of the Potomac River. Since 1983, the USGS has also supplied maps showing the general distribution of SAV, as well as the location and amount of the exotic submersed macrophyte *Hydrilla verticillata*, to the Metropolitan Washington Council of Governments to assist in its management program (Carter et al. 1985; Rybicki et al. 1985, 1986, 1987, 1988).

## Geographic Information System Activities

A GIS combines two computer software technologies: data-base management and digital mapping (Lanfear 1989). Data-base management is a systematic way of organizing and accessing tabular data and interfacing the data with maps. The key feature of a GIS is that the digital map elements are linked with the tabular information in such a way that when the map or the tabular data are manipulated, both sets of data are updated and adjusted to maintain the relation between them. GIS technology is a promising tool for combining wetland maps, such as those produced by the U.S. Fish and Wildlife Service, with hydrologic and geochemical information to detect and analyze stresses; to analyze potential effects of water qual-

ity or quantity changes in wetlands or loss of wetlands on water quality and flood-flow characteristics; and to make management and siting decisions. The USGS has installed GIS's at more than 50 sites, including 3 USGS regional GIS laboratories, so that nearly every hydrologist has access to a GIS.

## Toxics

The USGS is studying the distribution of toxic materials and pollutants in groundwater and surface water in many parts of the United States; GIS technology has many potential uses in the study of such contamination in wetlands. One recent study involving wetlands is determining the effects of contaminants (specifically selenium) in irrigation drainage on wetland areas of the middle Green River basin in Utah (Stephens and Waddell 1989). Elevated concentrations of selenium in biological tissue are known to be harmful to wildlife; impairment of reproduction in waterfowl can occur at selenium concentrations as low as 1 to 5  $\mu\text{g/g}$  (wet weight) in bird eggs. Elevated concentrations of selenium have been found in Utah's water in the Stewart Lake Waterfowl Management Area, in Ashley Creek, and in Ouray National Wildlife Refuge. The USGS study showed that the sources of selenium at the Stewart Lake Waterfowl Management Area are runoff from irrigated land and the discharge of shallow groundwater from sedimentary deposits of marine and nonmarine origin. Concentrations of selenium in irrigation drainage entering Stewart Lake ranged from 14 to 140  $\mu\text{g/L}$ . Tissues of American coot (*Fulica americana*) and carp from the lake contained concentrations as high as 26  $\mu\text{g/g}$  (dry weight). Contamination of Ashley Creek is from springs, seeps, and subsurface drains that discharge water containing as much as 16,000  $\mu\text{g/L}$  of selenium. Selenium concentrations in a pond in Ouray National Wildlife Refuge, which also receives irrigation runoff and shallow groundwater, were as high as 93  $\mu\text{g/L}$ ; the principal source of contamination is shallow groundwater containing as much as 9,300  $\mu\text{g/L}$  of selenium. Concentrations of selenium in coot embryos and eggs from the refuge ranged from 6.5 to 15  $\mu\text{g/g}$  (wet weight).

GIS technology has been used to support the Utah study. The ARC/INFO system produced maps showing the distribution of seleniferous formations, waterfowl (wetland) areas, and associated concentrations of selenium in source waters.

Currently being developed are large-scale maps showing the distribution of waterfowl nests in contaminated areas, as well as small-scale maps showing the numbers and types of banded and captured waterfowl within selenium-contaminated areas of Utah. A time-series of maps such as these could be used to show trends in the concentrations of selenium over time.

### *Spatial Analysis of Statewide Water Quality*

Federal law requires State governments to assess water quality to aid in the design and assess the effectiveness of pollution-control programs dealing with both point and nonpoint sources of pollution. In New Jersey, the USGS is using regression techniques to correlate a variety of water-quality characteristics with spatially detailed information on land use and pollution sources. Ambient water-quality data and pollutant-loading rates for individual municipal and industrial point sources are provided by the New Jersey Department of Environmental Protection. Information for estimating nonpoint-source contaminant loads is being derived from spatially detailed population data and digital land use and land cover data. Land use and land cover classification is based on existing 1973 Geographic Information Retrieval and Analysis System (GIRAS) coverage, updated to 1985 conditions through the use of Landsat Thematic Mapper data. Overland flow paths and channel networks are identified through the use of digital elevation data. Once constructed, the regression model is applied to a large and representative sample of stream reaches to obtain unbiased estimates of water-quality conditions. Potential uses for the methodology developed in the project include comparison of water quality in basins that have numerous wetlands with basins without wetlands, and identification of wetlands that might be threatened or affected by contaminants (e.g., bioaccumulation of toxicants in plant and animal tissue). The quality of water discharging from wetlands could also be included in the assessment of water quality statewide.

### **Identification of National Trends**

The USGS is testing and refining concepts for a National Water-Quality Assessment (NAWQA)

Program. The goals of this program (Hirsh et al.) are to (1) provide a nationally consistent description of current water-quality conditions for a large part of the Nation's water resources, (2) define long-term trends (or lack of trends) in water quality, and (3) identify, describe, and explain the major factors that affect observed water-quality conditions and trends.

The USGS is conducting seven NAWQA pilot projects of surface water and groundwater systems. One study is of groundwater on the Delmarva Peninsula (Maryland, Delaware, and Virginia). In the initial phase of this project, all historic data on groundwater quality through 1987 were collected and analyzed (Hamilton et al. 1989). The peninsula was divided into six subregions, each having a distinctive combination of hydrogeologic and landscape features, such as surficial geology, geomorphology, soils, and land use patterns. Each of the regions (referred to as hydrogeomorphic regions) represents a landscape with differing hydrologic characteristics, which presumably reflect differing water-quality patterns. One of these regions is a central upland that accounts for more than 25% of the study area. This region has hummocky topography, is poorly drained, and contains hundreds of seasonally ponded wetlands. The study team is observing local water-quality patterns around a few of the wetlands, but it is also investigating the effects of wetlands on water-quality patterns throughout the region, thus underscoring the importance of recognizing and mapping wetlands terrains as well as individual wetlands. Inclusion of water-quality and landscape-feature data in GIS data bases will permit the USGS to determine water-quality patterns influenced by wetlands at local and regional scales.

Historical data are important for predicting national water-quality trends; these data make it possible to compare water quality in basins as a function of numbers and types of numerous wetlands, as well as to examine the effect of changes in wetland type or acreage on basin water quality. The National Stream Quality Accounting Network (NASQAN) provides a continuous record of water quality at 441 active stations throughout the country for use in assessing water-quality trends (Briggs 1978). Of these, 150 stations are in coastal areas (USGS accounting units) and provide long-term (> than 10 years) data for trend analysis. Coastal accounting units, including those along the Great Lakes, usually contain numerous small

streams with roughly parallel drainage's flowing into the oceans or Great Lakes. Streams in each of the coastal units reflect similar geographic, geologic, and hydrologic conditions, although cultural features may differ.

Water-quality constituents currently are measured at NASQAN stations bimonthly or quarterly. Determinations resulting from each site visit include field measurements of temperature, pH, specific conductance, dissolved oxygen, and bacteria; common constituents; major nutrients; and suspended sediment. Quarterly samples are used to determine concentration of trace elements in addition to the constituents previously mentioned. Data collected from NASQAN are available from the USGS WATSTORE (Water Storage and Retrieval) computer storage and retrieval system. Data also are published in the series *Water Resource Data for (State), Water Year (date)*. These data are being used for trend analysis (Smith et al. 1987) and load estimates for nutrients and common constituents. Load and trend estimates can be related to basin characteristics, including the number and types of basin wetlands.

## U.S. Geological Survey Data Sources

The USGS provides many types of information for wetland managers and data users. Earth Science Information Centers (ESIC) offer nationwide information and sales service for USGS map products and earth science publications. This network of ESIC's provides information about geologic, hydrologic, topographic, and land use maps, books, and reports; aerial, satellite, and radar images and related products; earth science and map data in digital format, and related applications software; and geodetic data. For further information, contact any of the ESIC's listed in the Appendix.

ESIC offices assist users in securing publications and associated products in the earth science disciplines and use many computerized information systems to research inquiries. These systems include the Geographic Information and Retrieval System for land use and land cover maps and associated overlays (e.g., political and demographic), and the Earth Science Data Directory for information about earth science and natural resource data bases maintained by government agencies and other sources.

## Water Resources Information

The Office of Water Data Coordination is the focal point for interagency coordination of ongoing and planned water data-acquisition activities of all Federal agencies and many non-Federal organizations. The *National Handbook of Recommended Methods for Water-data Acquisition* and other publications are available from this office.<sup>1</sup>

The National Water Data Exchange (NAWDEX) maintains a computerized data system that identifies sources of water data and indexes information on the water data available from the sources. The NAWDEX Program Office and Local Assistance Centers assist data users in locating sources of water data, identifying sites at which data have been collected, and obtaining specific data.<sup>2</sup>

Questions about water resources in general, and about the water resources of specific areas of the United States can be directed to the USGS Hydrologic Information Unit. This office also will answer inquiries about the availability of reports of water-resource investigations.<sup>3</sup>

## Summary

The USGS collects, interprets, and supplies hydrologic data to supplement and enhance the use of wetland maps. Wetland maps supply the user with essential spatial information about wetland location, size, and relation to other basin and landscape features. Hydrologic data are needed to increase the usefulness of these maps for planning, managing, evaluating, and mitigating loss or degradation of wetlands. Long-term information about trends in water quality and quantity can assist the manager in detecting or predicting the effects of various management practices on wetlands or the effects of wetlands on local or regional water quality. The inclusion of hydrologic information in a GIS that uses wetland maps as a significant layer of information can greatly expand the analysis capabilities of the GIS for wetland planners and managers.

Federal agencies are responding to the increasing national emphasis on slowing the rate of wetland loss and improving wetland evaluation and

<sup>1</sup> Office of Water Data Coordination, U.S. Geological Survey, 417 National Center, Reston, Va. 22092.

<sup>2</sup> National Water Data Exchange, U.S. Geological Survey, 421 National Center, Reston, Va. 22092.

<sup>3</sup> Hydrologic Information Unit, U.S. Geological Survey, 420 National Center, Reston, Va. 22092.

mitigation. The USGS will be reassessing the ability of traditional data-collection and dissemination programs to provide information needed by wetland managers. The Federal-State Cooperative Program is refocusing its activities as a result of changing demands for basic hydrology information for wetlands. The USGS has already proposed a process-oriented interdisciplinary research program focusing on the hydrologic, geologic, and geochemical processes in wetlands. The objectives of this research are to improve understanding of the integrated hydrologic, geologic, and geochemical functions of wetlands, and to develop predictive capabilities for the evaluation of stresses on wetland environments. This will be accomplished through research on (1) the current hydrologic and geologic processes that create and maintain wetlands and lakes, including the movement of atmospheric, surface water, and groundwater, and the associated transport of sediment and chemicals; and (2) the geomorphic and hydrologic processes that control the evolution of wetlands. A major component of the research would be support of long-term studies at several selected wetland systems that represent a variety of regional hydrologic, geologic, and climatic environments in the United States.

## References

- Briggs, J. C. 1978. Nationwide surface water quality monitoring networks of the U.S. Geological Survey. Pages 49-57 in Establishment of water quality monitoring programs. Proceeding of the American Water Resources Association. 12-14 June 1978.
- Carswell, W. J., Jr., C. L. Sanders, Jr., and D. M. Johnson. 1988. Freshwater supply potential of the Atlantic Intracoastal Waterway near Myrtle Beach, South Carolina. U.S. Geol. Surv. Water-Resour. Invest. Rep. 88-4066. 45 pp.
- Carter, V., N. B. Rybicki, R. T. Anderson, T. J. Trombley, and G. L. Zynjuk. 1985. Data on the distribution and abundance of submersed aquatic vegetation in the tidal Potomac River and transition zone of the Potomac estuary, Maryland, Virginia and the District of Columbia, 1983 and 1984. U.S. Geol. Surv. Open-File Rep. 85-82. 61 pp.
- Hamilton, P. A., R. J. Shedlock, and P. J. Phillips. 1989. Groundwater-quality assessment of the Delmarva Peninsula, Delaware, Maryland, and Virginia—analysis of available water-quality data through 1987. U.S. Geol. Surv. Open-File Rep. 89-34. 72 pp.
- Hirsh, R. M., W. M. Alley, and W. G. Wilber. 1988. Concepts for a national water-quality assessment program. U.S. Geol. Surv. Circ. 1021. 42 pp.
- Lanfeard, K. J. 1989. Geographic information systems and water resources applications. Water Resour. Bull. 25:v-vi.
- Meade, R. H., and R. S. Parker. 1985. Sediment in rivers of the United States. U.S. Geol. Surv. Water-Supply Pap. 2275:49-61.
- Meade, R. H. 1989. Sediment-transported pollutants in the Mississippi River. U.S. Geol. Surv. Yearb. Fiscal Year 1988:20-23.
- Periera, W. E., C. E. Rostad, and T. J. Leiker. 1989. Preliminary assessment of the fate and transport of synthetic organic agrochemicals in the lower Mississippi River and its tributaries. Pages 453-464 in U.S. Geol. Surv. Water-Resour. Invest. Rep. 88-4220.
- Rybicki, N., R. T. Anderson, and V. Carter. 1988. Data on the distribution and abundance of submersed aquatic vegetation in the tidal Potomac River and transition zone of the Potomac estuary, Maryland, Virginia and the District of Columbia, 1987. U.S. Geol. Surv. Open-File Rep. 88-307. 31 pp.
- Rybicki, N., R. T. Anderson, J. M. Shapiro, C. L. Jones, and V. Carter. 1986. Data on the distribution and abundance of submersed aquatic vegetation in the tidal Potomac River, Maryland, Virginia and the District of Columbia, 1985. U.S. Geol. Surv. Open-File Rep. 86-126. 49 pp.
- Rybicki, N. B., R. T. Anderson, J. M. Shapiro, K. L. Johnson, and C. L. Schulman. 1987. Data on the distribution and abundance of submersed aquatic vegetation in the tidal Potomac River and estuary, Maryland, Virginia and the District of Columbia, 1986. U.S. Geol. Surv. Open-File Rep. 87-575. 82 pp.
- Rybicki, N. B., V. Carter, R. T. Anderson, and T. J. Trombley. 1985. *Hydrilla verticillata* in the tidal Potomac River, Maryland, Virginia and the District of Columbia, 1983 and 1984. U.S. Geol. Surv. Open-File Rep. 85-77. 26 pp.
- Smith, R. A., R. B. Alexander, and M. G. Wolman. 1987. Water-quality trends in the Nation's rivers. Science 235:1607-1615.
- Stephens, D. W., and B. Waddell. 1989. Selenium contamination from irrigation drainage in the western United States with emphasis on Utah. Geology and hydrology of hazardous waste, mining waste, waste water, and repository sites in Utah. Utah Geol. Assoc. Publ. 17:165-181.
- Taylor, H. E., J. R. Garborino, and T. I. Brenton. 1989. The occurrence and distribution of trace metals in the Mississippi River and its tributaries. Sci. Total Environ. In press.

## Appendix. Earth Science Information Centers (ESIC's)

---

Anchorage-ESIC  
4230 University Drive, Room 101  
Anchorage, Alaska 99508-4664  
(907)561-5555

Anchorage-ESIC  
U.S. Courthouse, Room 113  
222 W. 7th Avenue, #53  
Anchorage, Alaska 99513-7546

Denver-ESIC  
169 Federal Building  
1961 Stout Street  
Denver, Colorado 80294  
(303)844-4169

Lakewood-ESIC  
Box 25046, Federal Center, MS 504  
Denver, Colorado 80225-0046  
(303)236-5829

Los Angeles-ESIC  
Federal Building, Room 7638  
300 N. Los Angeles Street  
Los Angeles, California 90012  
(213)894-2850

Menlo Park-ESIC  
Building 3, Room 122, Mail Stop 33  
345 Middlefield Road  
Menlo Park, California 94025  
(415)329-4309

Reston-ESIC  
507 National Center  
12201 Sunrise Valley Drive  
Reston, Virginia 22092  
(703)860-6045

Rolla-ESIC  
1400 Independence Road, MS 231  
Rolla, Missouri 65401  
(314)341-0851

Salt Lake City-ESIC  
8105 Federal Building  
125 South State Street  
Salt Lake City, Utah 84138  
(801)524-5652

San Francisco-ESIC  
504 Custom House  
555 Battery Street  
San Francisco, California 94111

Spokane-ESIC  
678 U.S. Courthouse  
W. 920 Riverside Avenue  
Spokane, Washington 99201  
(509)353-2524

Stennis Space Center-ESIC  
Building 3101  
Stennis Space Center, Mississippi 39529  
(601)688-3544

Washington, D.C.-ESIC  
Department of Interior Building  
18th and C Streets, N.W., Room 2650  
Washington, D.C. 20240  
(202)343-8073

## The U.S. Geological Survey's National Mapping Division Programs, Products, and Services that can Support Wetlands Mapping

by

Franklin S. Baxter

*U.S. Geological Survey  
National Mapping Division  
National Center, MS-590  
Reston, Virginia 22092*

**ABSTRACT.**—The U.S. Geological Survey (USGS) programs can play an important role in support of President Bush's policy of no net loss of wetlands. A principal goal of USGS is to provide cartographic information that contributes to the wise management of the Nation's natural resources. This information consists of maps, cartographic data bases (graphic and digital), remotely sensed imagery, and information services. These products are used by Federal, State, and local governments, the private sector, and individual citizens in making decisions on the existence and use of land and water resources. The identification and classification of wetlands and the activities that affect the quantity, fate, and character of wetlands are described, analyzed, and monitored through the use of cartographic data. There are several specific areas where USGS's National Mapping Division can support the study of wetlands. These include supplying a cartographer to the U.S. Fish and Wildlife Service's St. Petersburg facility to review National Wetlands Inventory (NWI) program procedures and to identify cost- and time-efficient methods for accelerating the inventory; assisting the NWI in using National Aerial Photography Program products for interpretation of wetlands; assisting in research to standardize scanning procedures, to train NWI personnel, and to incorporate data into the National Digital Spatial Data Base System; and integrating data from the NWI program with the National Mapping Division's land use and land cover data and topographic map data. I discuss the programs, products, and information services of the National Mapping Division, the tools available to determine where wetlands exist, and the capability of periodic measurement of wetlands to help in assessing compliance with the concept of no net loss of wetlands.

President Bush's policy of no net loss of wetlands is resulting in a refocus of priorities for the collection, processing, and publishing of cartographic data. The National Mapping Division of the United States Geological Survey (USGS) has been collecting wetlands information as part of its National Mapping Program for a number of years. The refocusing of priorities will ensure that data collection will directly support the president's initiative.

### Programs, Products, and Services of the National Mapping Division

The National Mapping Division provides a diversity of cartographic, geographic, and remotely sensed data, products, and services in support of Federal, State, and public interests through the National Mapping Program. These products and



services include cartographic and geographic information about the earth's natural and cultural features, basic and special maps in several scales, digital cartographic data, and remotely sensed data. The division prepares standard topographic maps at specified scales and revises existing maps to provide current and accurate cartographic data.

The cartographic data needs of Federal and State programs are identified and ranked by priority under the Office of Management and Budget's Circular A-16 process. Circular A-16, revised in 1967, names the Department of the Interior (delegated to the U.S. Geological Survey) as "responsible for the National Topographic Mapping Series of the United States of America and outlying areas of sovereignty and jurisdiction" and for exercising "governmentwide leadership in assuring coordinated planning and execution" of cartographic activities that are funded in whole or in part with Federal funds. This directive was expanded to include digital cartography in 1983.

The primary map series provides the largest-scale information available on a nationwide basis. This series includes the 7.5-min topographic quadrangle maps of Hawaii, Puerto Rico, and the conterminous United States. In Alaska, the series provides 15-min topographic quadrangle map coverage. Many Federal and State programs rely on this map series as a base for site-specific environmental studies or as the primary series for recording information relative to their program needs. A major goal of the National Mapping Division is to achieve initial once-over national coverage in this map series by the end of fiscal year (FY) 1990. Maps covering about 95% of the United States have been published, and advance manuscript copies are available for an additional 2%. Orthophotoquads at 1:24,000 scale also are available for about two-thirds of the United States.

The currentness, accuracy, and usefulness of the primary map series will be maintained through an expanded map revision program. The National Mapping Division has begun a comprehensive plan for the identification and scheduling of map revisions that would be most beneficial to Federal and State agencies and the general public. The most efficient methods for revising the primary scale maps are being tested, and procedures for incorporating user requirements identified through the Circular A-16 process are being devised. Projects that reflect the most urgent needs of the user are being designed for short-term production.

The use of graphic maps is being supplanted rapidly by the use of base digital cartographic data because such data are more useful and are cost-efficient to maintain and apply. The National Mapping Division is collecting digital cartographic data to meet the needs of a wide variety of users, and is producing data in both digital line graph and digital elevation model formats. Digital data revision methods aid in the recording of changes to the natural and cultural environment. Also, digital cartographic data are essential in analyzing the impact of environmental problems in a geographic information system (GIS) context. The National Mapping Division has devoted considerable effort to developing and promoting the standards and specifications necessary to ensure accessibility and usability of base cartographic data throughout the Federal government. Working through the Federal Interagency Coordinating Committee on Digital Cartography and the Interior Digital Cartography Coordinating Committee, other Federal agencies have been encouraged to develop their own digital capabilities and have supported the development of a National Wetlands Data Base and a National Soils Data Base.

Other map products that have been useful in Federal and State programs are the intermediate-scale maps at 1:50,000 scale and 1:100,000 scale in quadrangle and county formats. The National Mapping Division plans to complete the 1:100,000-scale topographic map series in FY 95. In 1989, there were about 650 maps available as planimetric editions, about 950 available as Bureau of Land Management editions (surface and subsurface mineral overlays), and another 25 available as advance manuscript copies. The 1:50,000-scale quadrangle maps are produced to meet a Defense Mapping Agency requirement but are made available to the general public. The county-formatted maps are produced as needed on a cooperative basis with individual States.

The intermediate-scale maps also are being digitized to support the planning needs of Federal and State agencies. Currently, all hydrographic and transportation data at the 1:100,000 scale are available. Other categories of data, such as hypsography (contours), public land information, boundaries, and digital elevation models, are produced in response to Federal and State agency requirements.

Many Federal and State agencies use a combination of intermediate-scale products and data for planning purposes and larger-scale data for more

detailed analyses, whereas some agencies are satisfied with the level of information at an intermediate scale for land management and environmental studies. For example, time and cost benefits can be realized by locating study areas from a regional perspective and obtaining source material (photographic coverage, base maps, or appropriate digital data) for only those areas where more detailed analyses are needed.

The National Mapping Division is conducting pilot projects to investigate the benefits of producing a large-scale orthophotoimage product and of revising the land use and land cover map series at a larger scale. In both instances, the division is responding to specific requirements expressed by Federal and State agencies through the Circular A-16 process.

The National Mapping Division is assessing the value of land use and land cover map revisions at the 1:100,000 scale. Now that completion of the topographic editions at this scale is within sight, the use of these maps as a base for land use and land cover mapping based on an enhanced classification system seems quite promising. Many Federal and State agencies have expressed interest in designing the classification system for use in a GIS environment. Currently, the land use and land cover mapping program results in maps and associated information (political boundaries, hydrologic units, and census county subdivisions) at the 1:250,000 scale. The lower 49 States are covered at this scale; about 85% of these maps have been digitized using the Geographic Information Retrieval and Analysis System. The maps and data are becoming out-of-date, and use of the Geographic Information Retrieval and Analysis System is not widespread. In addition to the benefits to State users, a larger-scale mapping and digital data program will benefit wetland analyses and other studies, such as global change research.

The National Aerial Photography Program (NAPP) provides standardized and uniform quality photographic coverage of the 48 conterminous States on a planned 5-year acquisition cycle. Color-infrared photographs, at a scale of 1:40,000, are centered on quarter sections of each standard 7.5-min USGS quadrangle. NAPP contracts awarded in 1989 cover all or part of Arkansas, southern California, Louisiana, South Carolina, Texas, eastern Virginia, and Wyoming. Those Federal agencies or States that participate in the NAPP program receive a discount on all NAPP products. NAPP products are available from USGS's EROS

Data Center in Sioux Falls, South Dakota, and the U.S. Department of Agriculture's Aerial Photography Field Office in Salt Lake City, Utah.

Image maps, primarily orthophotoquads, are prepared in response to specific requirements of Federal and State agencies. Orthophotoquads are scale-rectified image bases that meet national map accuracy standards, are produced from NAPP photographs, and are prepared at 1:24,000, 1:63,360, or 1:12,000 scales. These image bases can be produced in about one-third the time required for topographic maps; however, they contain no contours and only a limited number of feature names. During FY 89, the National Mapping Division prepared 1,178 orthophotoquads at 1:24,000 scale, 140 at 1:12,000 scale, and, in Alaska, 175 at 1:63,360 scale. Presently, about 40,000 orthophotoquads are available, covering more than two-thirds of the conterminous United States, all of Hawaii, and a portion of Alaska. Much of the work is produced directly from requests from the Bureau of Land Management and the Soil Conservation Service.

The cornerstone of the National Mapping Division's information delivery network is the Office of Information and Data Services. This office manages the Earth Science Information Center (ESIC) network composed of 13 ESIC offices, and 1 Federal and 61 State ESIC affiliates. Developed through the merging of National Cartographic Information Centers and the Public Inquiries Offices, ESIC's responded to about 567,000 inquiries last year. ESIC offices maintain data records in such publications as the Cartographic Catalog, the Map and Chart Information System, and the Aerial Photography Summary Record System.

The EROS Data Center produces high-quality map products from satellite data for a variety of Federal and international organizations. The EROS Data Center archives more than 800,000 Landsat scenes and, in 1990, will have more than 150,000 Thematic Mapper scenes and Advanced Very High Resolution Radiometer data for the entire country. The EROS Data Center has established agreements with the commercial companies EOSAT and SPOT Image Corporation to serve as a single point of contact to purchase Landsat and SPOT data for Federal agencies. In the mid-1990's, the EROS Data Center will process, archive, and distribute remotely sensed land data acquired by selected sensors flown by the National Aeronautic and Space Administration's Earth Observing System.

## Applications to Wetlands Studies

The following are several examples of National Mapping Division products and how these products are used by other Federal agencies in wetlands studies.

### *Primary Map Series*

(1:24,000-scale maps in the conterminous United States and Hawaii, and 1:63,360-scale maps in Alaska)

- U.S. Fish and Wildlife Service  
Conterminous United States—to serve as a base map of the National Wetlands Inventory conducted by the U.S. Fish and Wildlife Service.  
Coastal Louisiana—to revise maps to better reflect the loss of coastal wetlands to support studies on the effects of habitat loss.
- National Park Service  
Cape Cod National Seashore—to update and correct topographic maps to better portray coastal wetland areas.  
Wrangell–St. Elias National Park and Preserve—to update maps to portray the current topographic situation, including development of wetlands because of rapid glacial retreat.
- Environmental Protection Agency  
Horry County, South Carolina—to revise maps to assist in the study of the creation, maintenance, and impact of environmental problems on Carolina Bays.

### *Intermediate-scale Maps*

(1:50,000-scale and 1:100,000-scale maps in quadrangle and county formats, and 1:250,000-scale quadrangle maps)

- U.S. Fish and Wildlife Service  
Coastal areas of the southern United States—to update maps to reflect the rapid loss of coastal wetlands in Alabama, Louisiana, Mississippi, and Texas.
- National Park Service  
Kenai Fjords National Park—to update maps for recording the creation of wetlands and other conditions due to glacial recession.

## *Digital Data*

(Digital line graphs and digital elevation models at several scales)

- U.S. Fish and Wildlife Service  
Coastal areas of the southern and eastern United States—to be used as ancillary data bases for wetlands habitat data.  
Lake Okeechobee—to support wetlands studies being conducted by FWS's Region 8 Florida Cooperative Fish and Wildlife Research Unit.
- National Park Service  
Cape Cod National Seashore—to support use of a GIS in the monitoring of land use changes, including wetlands.  
Cumberland Island National Seashore—to study, with several other agencies, a variety of activities along the coast, including emergency preparedness and habitat studies.
- Other areas where digital data are to be used to support wetlands studies:
  - Okefenokee National Wildlife Refuge, Georgia–Florida
  - The Everglades, Florida
  - Galveston Bay, Texas
  - San Joaquin Valley, California
  - Malheur National Wildlife Refuge, Oregon
  - Charles M. Russell National Wildlife Refuge, Montana
  - Hawaiian Islands
  - Mobile Bay, Alabama
- Environmental Protection Agency  
Areas where hydrographic data are needed to support related habitat and wetlands studies:
  - Albemarle/Pamlico Environmental Study, North Carolina
  - Merrimack River, Massachusetts–New Hampshire
  - Massachusetts Bays, Massachusetts
  - Slidell, Louisiana
  - Edisto River and Horry County, South Carolina
  - Chesapeake Bay Study, Virginia, Maryland, Pennsylvania
  - Narragansett Bay, Rhode Island

### *Land Use and Land Cover*

(The National Mapping Division is considering the creation of a new series of land use and land cover maps at the 1:100,000 scale. The wetlands classifications would be developed in coordination with the U.S. Fish and Wildlife Service.)

Areas where land use and land cover data are needed include:

- National Park Service
  - Big Thicket National Preserve, Texas
  - Saratoga National Historic Park, New York
- Environmental Protection Agency
  - Chesapeake Bay Study, Virginia, Maryland, Pennsylvania
  - Albemarle/Pamlico Study Area, North Carolina
  - Pearl River Basin, Louisiana
  - Savannah River Basin, Georgia
  - Georgetown and Beaufort, South Carolina
  - Delaware Bay, Delaware, New Jersey

### *Image Maps*

The National Mapping Division is investigating the usefulness of new maps that could enhance the study of wetlands. This includes the development of a new series of image-based maps at the 1:12,000 scale, called quarter-quad orthophotos. The use of these maps could result in the more precise recording of the existence and extent of wetlands. Because the orthophotoquad production process is much shorter than the production of standard topographic map revisions and the positional accuracy is comparable with the revised map, the orthophotoquad could become an essential tool in the study of wetlands.

The Soil Conservation Service, Department of Agriculture, has been working with the National Mapping Division on designing an image base map at the 1:12,000 scale in support of the national soils inventory. These image maps are used by Soil Conservation Service field personnel; they are produced under a joint funding arrangement and use NAPP photographs as source materials. As the use of 1:12,000-scale orthophotoquads increases, the division will assess its position on standardizing the compilation and final design to reflect the most advantageous use of this product. At present we believe that the 1:12,000-scale orthophotoquad can be an integral part of wetlands research.

## **Coordination Efforts in Wetlands Research and Technical Assistance**

Several research studies, program initiatives, and coordination ventures that relate to wetlands are being pursued in cooperation with Federal and State agencies. Examples of these include programs in Mystic, Connecticut; Elizabeth River, Virginia; James River, Virginia; and the Prairie Pothole region in the Midwest.

As the use and acceptance of GIS technologies become more widespread at all levels of government, the reliance on computer-based environmental studies in the USGS will increase accordingly. Several studies are being conducted by the National Mapping, Water Resources, and Geologic divisions that investigate the quality of water in a wetlands environment, the creation and maintenance of wetlands, and the effect of human activities on wetlands. GIS projects that are underway include management of hazardous waste sites, some of which have direct effects on nearby wetlands; the movement of toxins through groundwater and surface water; and continuing research on the environmental health of the Chesapeake Bay drainage area. The wetlands ecosystem provides investigators with a natural laboratory in which complex environmental processes can be investigated. GIS modeling allows scientists to further expand the horizon of scientific inquiry by permitting effective visualization and the interaction of the many complex data sets involved, while simultaneously providing the capability for the quantified investigation of spatial and temporal patterns in the data.

The National Mapping Division and the National Wetlands Inventory staffs are pursuing the development of formal agreements to conduct mapping activities that will result in mutually beneficial data production and use. The three principal objectives of these cooperative ventures are sharing of personnel, technology, and data.

With regard to personnel, the National Mapping Division proposes to make a cartographer available to NWI for a maximum of 2 years to review the production processes for the generation of national wetlands maps. A remote-sensing specialist also will be available on an as-needed basis to identify the most effective use of NAPP photographs, the procedures for handling large amounts of new source materials, and the conventions re-

quired to classify wetlands from NAPP source materials.

With regard to technology, the National Mapping Division proposes to identify state-of-the-art software and hardware systems to assist in standardizing scanning procedures, to assist NWI personnel in developing techniques to convert NWI graphic products to digital products, and to assist in quality-assurance procedures so that wetlands data can be incorporated into the National Digital Spatial Data Base System. This technical assistance will reduce duplicative efforts, ensure data collection meets national standards, maximize program efficiencies, and encourage technology transfer.

With regard to data, a cooperative effort is necessary for transfer of wetlands data from the NWI directly to the National Digital Spatial Data Base System. These data will be important for the efficient conduct of the National Map Revision Program and the land use and land cover mapping effort. Procedures could be developed to assist in the revision and updating of wetlands data currently recorded on the 1:24,000-scale topographic map series and to update the land use and land cover maps that require current wetlands classification and mapping. This effort also will ensure that the most current wetlands data are available to the general public through the National Digital Spatial Data Base System.

## Summary

The National Mapping Division produces and disseminates a variety of cartographic, image, and digital maps and data that are useful to Federal and State agencies involved in wetlands research. The primary map series is most often used, in both

graphic and digital form. For project planning, the intermediate-scale maps and data provide a regional perspective. Some Federal agencies are now increasing their support of even larger-scale maps and data, primarily in an image format. The National Mapping Division is investigating the usefulness of quarter-quad orthophotographic products to respond to this growing need. Data dissemination networks are in place and accessible to Federal and State agencies nationwide.

Currently, the National Mapping Division is providing support to the National Park Service, the U.S. Fish and Wildlife Service, the U.S. Environmental Protection Agency, the Soil Conservation Service, the U.S. Army Corps of Engineers, the National Oceanic and Atmospheric Administration, and the U.S. Forest Service in a number of studies related to wetlands research. One of the most effective research tools in the study of wetlands is GIS, a technology in which the National Mapping Division has valuable expertise. The use of division maps and data in GIS's is increasing and is expected to continue. One of the major initiatives of the National Mapping Division is to provide technical assistance to any Federal or State agency that seeks cooperative development of wetland research projects.

The need for a coordinated approach to support the president's Wetland Initiative is being addressed by the National Mapping Division and the National Wetlands Inventory through the establishment of formal cooperative agreements. These agreements will involve the sharing of expertise, the development of a wetlands component in the National Digital Spatial Data Base System, and the exchange of wetland thematic and base cartographic data between the agencies.

## Soil Conservation Service's Wetland Inventory

by

Billy M. Teels

*Soil Conservation Service  
U.S. Department of Agriculture  
South Agriculture Building, Room 6144  
P.O. Box 2890  
Washington, D.C. 20013*

**ABSTRACT.**—The Soil Conservation Service (SCS) conducts its wetland inventory under the auspices of the Food Security Act (FSA) of 1985. Through the wetland conservation (Swampbuster) provision of FSA, agricultural producers are denied United States Department of Agriculture (USDA) program benefits for converting wetlands for agricultural production. The SCS has the technical responsibility for identifying FSA wetlands and converted wetlands. The USDA program agencies (Agricultural Stabilization and Conservation Service, Farmers Home Administration, and Federal Crop Insurance Corporation) determine producer eligibility for their respective programs once wetlands and converted wetlands have been identified. Critical to the effective implementation of Swampbuster is the accurate and timely identification of wetlands for affected persons and agencies. The SCS Wetland Inventory focuses on inland freshwater wetlands that have a high potential for agricultural conversion. The conversion of wetlands to agricultural land has accounted for more than 80% of the Nation's wetland loss. The SCS has set a goal of 31 December 1991 to complete wetland determinations for all USDA program participant croplands and other lands identified as having a high potential for conversion.

The Soil Conservation Service's (SCS) Wetland Inventory began in the Red River Valley of the north, in North Dakota and Minnesota, January 1988. Initially, SCS had not planned to conduct a wetland inventory for the Food Security Act (FSA) Swampbuster (the wetland conservation provision of the FSA) was to have worked based solely on producer certification, a process whereby the U.S. Department of Agriculture (USDA) program participants would certify annually on form AD-1026 as to their intent to modify wetlands. However, that process proved inadequate because producers did not know what was considered a wetland under FSA, nor did they know to what extent Swampbuster would allow for maintenance of existing drainage systems that involved wetlands. Therefore, on nearly all self-certification forms, producers had checked "no" in the blocks that asked if modifications were to be made in wetlands. Nevertheless, documented modifications in wetlands continued

to occur without detection by the self-certification process. Also, producers with lands in different States or counties would get different answers on what constituted a wetland, depending on where their land was located. It soon became evident that an inventory was necessary to avoid confusion on the location of wetlands and to clarify the extent to which maintenance could be performed. This condition was particularly true in the Red River Valley of the north, where most producers annually perform some maintenance of their drainage systems. If producers were going to comply with Swampbuster, wetlands had to be identified.

The inventory was a success in the Red River Valley. For the most part, producers agreed with the wetlands identified by the inventory, and conservation agencies and environmental groups were pleased with the results. Because of the variety of the information from which wetland interpretations were made and the large scale of the mapping

tools employed, the inventory identified more wetlands than had been identified in previous inventories. Even though more wetlands were identified, it was clear that the vast majority of delineations met the wetland definition under FSA, and that the inventory did not include land that was outside that definition. Producers in the Red River Valley appreciated that wetland determinations were made promptly and that they were made before the 1988 growing season when decisions had to be made on drainage maintenance and planting. The inventory ended the confusion, speculation, and conjecture that was plaguing Swampbuster at the time. Based on the success in the Red River Valley, SCS decided to expand the inventory elsewhere.

### Inventory Coverage to Date

Because the potential for agricultural conversion is low in much of the Nation's wetlands, SCS does not intend to conduct an inventory that covers the entire Nation. Only those regions considered to have high potential for conversion of wetlands to annual crops have been identified, and funds have been made available to States within those regions for inventory purposes (Fig. 1). The inventory is about 25% complete to date, with the greatest progress occurring in the Midwest (Fig. 2). FSA wetland determinations, for which the inventory was developed, are complete for about 25% of the USDA program participants.

### Scope of the Project and Project Period

As previously discussed, the scope of the inventory includes all lands that have a high potential for agricultural conversion. The 31 December 1991 date sets an ambitious goal for completed determinations, a goal difficult to achieve without the aid of an inventory. Inventory funds have been made available in fiscal years (FY) 1989, 1990, and 1991 to SCS State offices with an interest in conducting an inventory.

### Description of Map Products

Wetlands and converted wetlands are identified on a variety of map products. There is no standard scale or map on which the inventory is produced. However, wetland determinations are usually made on photocopies of black and white aerial photographs provided by the Agricultural Stabilization and Conversion Service (ASCS). There is a difference between wetlands identified for the inventory and wetlands identified during the determination process. The wetland inventory identifies more or less all the wetlands in a county or major land resource area, and is used as a tool from which wetland determinations are made. Wetland determinations are made on form CPA-026 by SCS. The producer and the program agency are provided a photocopy of an aerial photograph

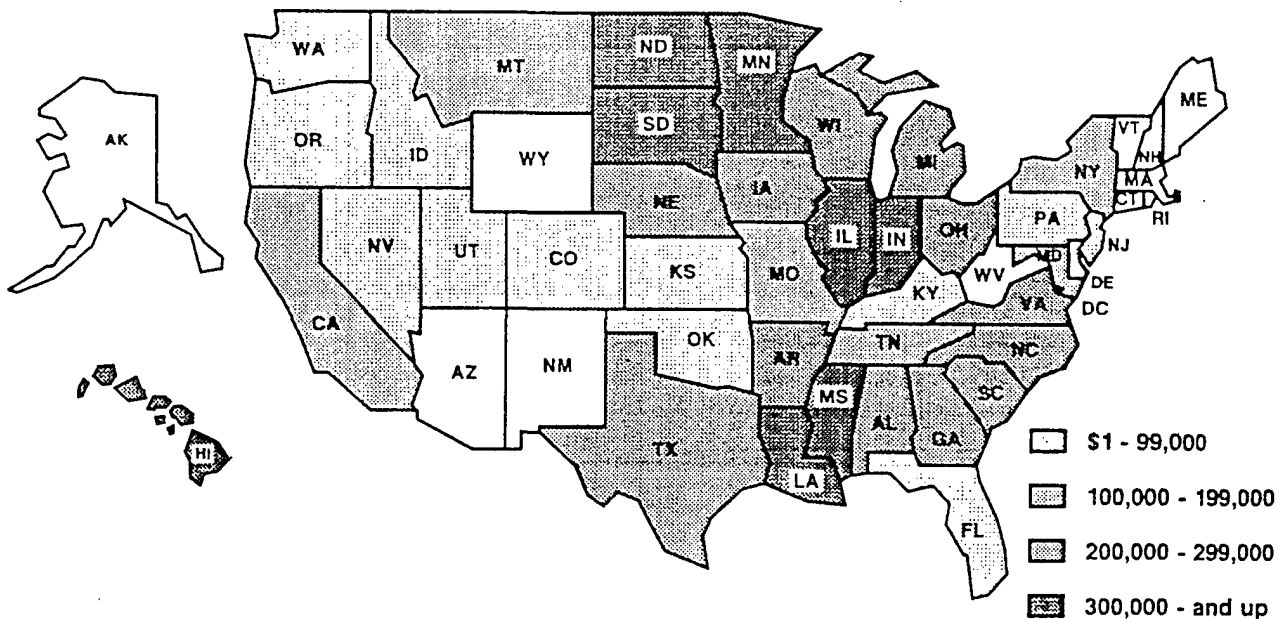

Fig. 1. 1989 allocations for wetland inventories.

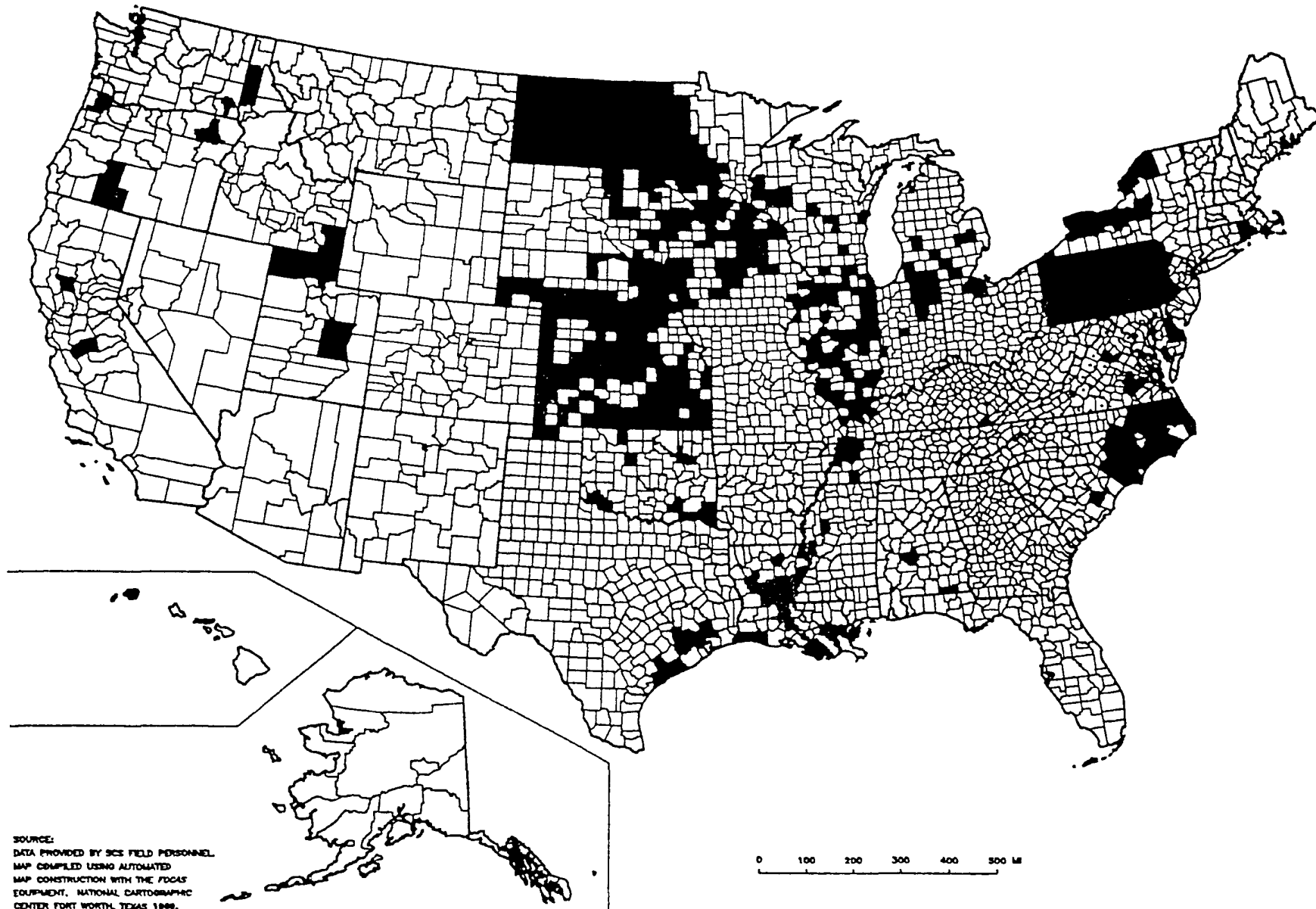

Fig. 2. Completed wetland inventories (September 1989) of the Soil Conservation Service.



of the producer's property delineating the wetlands and converted wetlands. The scale of the photography on which determinations are made varies; however, 8 inches per mile or 1:660 is the most common. Because this scale is used for most determinations, the inventory commonly uses this scale as its base. In most instances, SCS will order the latest black and white aerial photography (prints) at the same scale that ASCS uses for its programs on which to produce the inventory. Inventory delineations are made directly on the black and white prints with the appropriate FSA designations. Photocopies can then be conveniently made of the prints and provided to the program agency and program participants as part of the determination process. Some inventories use soil survey maps as a base; these vary in scale (1:10,000–1:12,000 for detailed surveys or 1:24,000–1:64,000 for extensive surveys). Other inventories have used satellite data to interpret wetlands and produce delineations on mylar overlays at a scale of 1:24,000.

Although there is no standard map product at this time, we anticipate that SCS wetland determinations eventually will be incorporated into a standardized county map system and a digital county data base that will be adopted by all USDA agencies.

## Inventory Methods

The FSA's definition of wetland is as follows: Lands that have a predominance of hydric soils that are inundated or saturated at a frequency and duration sufficient to support, and under normal circumstances do support, a prevalence of hydrophytic vegetation typically adapted to life in saturated soil conditions. This definition contains the three wetland parameters that have been used to identify wetlands under Section 404 of the Clean Water Act, and by the U.S. Fish and Wildlife Service (FWS) in the National Wetlands Inventory. Those same parameters are now recognized by the new *Federal Manual for Identifying and Delineating Jurisdictional Wetlands* (Federal Interagency Committee for Wetland Delineation 1989). The SCS's Wetland Inventory uses office information, such as ASCS compliance slides, other aerial photography, FWS National Wetlands Inventory maps, SCS soil surveys, local weather records, stream gauge data, and other locally available data, as the basis for determining if wetland soils, hydrology, and vegetation are present. Thus, the inven-

tory is an office process that shortcuts the need to make on-site wetland investigations and without a significant loss in accuracy.

Mapping conventions have been developed as a guide to interpret office information and provide consistency to the inventory. Conventions are generally developed for each SCS field office and are tailored to the information that is available locally. The SCS State offices have developed broad conventions for "major land resource areas" that serve as a framework through which field office mapping conventions are developed. Likewise, regional mapping conventions have been developed by SCS's National Technical Centers to serve as a guide for the development of State conventions. The appendix provides an example of a regionally developed mapping convention for the Prairie Pothole region. The mapping conventions are, in effect, the control over the inventory, and are usually codeveloped with the FWS. The SCS's National Technical Centers must concur with State mapping conventions before they can be used in the inventory.

Mapping is performed by teams of SCS technicians, SCS district conservationists, or by teams working with technical consultants. In much of the Midwest, SCS technicians are assigned to field offices to conduct the inventory. Once all the office information and collateral data (e.g., weather records, river gauge data) have been assembled, a three- or four-person team interprets the information based on the local mapping conventions, and makes the delineations on the base maps. The team can conduct the inventory for the field office area (usually a county) within about 2 weeks. Then the team moves on to the next field office and repeats the process. Before the team begins mapping, team members spend time at the field office familiarizing themselves with available mapping tools and conventions and becoming acquainted with the county's landscape and ecology. The local district conservationist contributes information based on his or her experience in the county. To ensure accuracy, the team members and the district conservationist make periodic field checks of the delineated wetlands during the mapping process.

The SCS area office staff annually reviews all of the field offices involved in the inventory, providing first-line quality control for the inventory. The SCS State offices annually spot-check a minimum of 10% of the field offices involved in the inventory and all of the area offices performing quality control. The SCS National Technical Centers annually review the performance of all State offices involved in

the inventory. Reviews focus on whether the teams are making accurate determinations as compared with determinations that would be made on site, and whether the teams are accurately applying the mapping conventions to the inventory tools.

The SCS State offices must approve each field office inventory before it becomes final and is released to the public. The inventory is made available to land users, first on an informal basis, either through direct mailing or by conducting public meetings to review the inventory. The land users are asked if they agree with the delineations. If they do, the SCS makes final determinations from the inventory and transmits them to the producer and the program agency through form SCS CPA-026. The form includes a representation of the producer's farm with wetlands and converted wetlands delineated, including information on the restrictions associated with the delineations. If the land users object to the determination, they can meet with the district conservationist to reconsider the determination. Many times the differences are resolved as a result of the meeting. At other times, the district conservationist may have to make an on-site determination, which then becomes the final determination. The FSA determination process thus provides a means for determinations to be made either from the office or on site, based on complexity of the determination and agreement of the land users. Where inventories have been completed, most final determinations have been made from the inventory with the land users' concurrence. However, if land users disagree with final wetland determinations, they can appeal the determinations through a formal appeals process.

In other instances (e.g., where the workload is relatively low or where the cost of establishing teams is prohibitive), the district conservationist conducts the inventory with the same mapping conventions and subject to the same quality control as a team. However, consistency usually suffers when the inventory is performed in this manner.

In the lower Mississippi Valley, satellite imagery has been used to conduct an inventory. In Mississippi, a State wetland inventory team has worked with the Stennis Space Center Institute for Technology Development to produce inventory maps for the Mississippi Delta with Landstat Thematic Mapper and Landstat Multispectral Scanner data from 1984 to 1989. The major reason for relying on satellite imagery in the Mississippi Delta is to verify seasonal flooding (inundation for 15 consecutive days during the growing season), which FSA

requires to qualify as a farmed wetland. The team and representatives from the Stennis Space Center correlated river gauge data from the Mississippi and Yazoo rivers with available satellite imagery showing flooding or ponding that equaled or exceeded 15 days. FSA wetland and converted wetlands were then color-coded on mylar overlays at a scale of 1:24,000.

## Cartographic Procedures

Wetland delineations are hand-drawn on existing maps or photographs. Interpretations are made according to the mapping conventions to determine if an area is a wetland, and then the technician interprets the extent of the wetland boundary based on the signatures produced from the various imagery or lines drawn on other wetland maps (e.g., National Wetland Inventory maps). Lines are normally drawn without the aid of transfer scopes and without rules to ensure consistency of the delineations. However, land users seldom appeal the boundary lines that SCS produces.

## Availability of Map Products

The SCS's primary responsibility under FSA is to make wetland and converted wetland determinations for USDA program participants and USDA program agencies. Because of an intense focus on providing wetland information to primary users in a short period, there has been no concentrated effort to make the SCS Wetland Inventory available to the general public. However, interested persons can request photocopies of specific wetlands from SCS State conservationists. In addition to the inventory, other information is available from the SCS to aid others in making wetland determinations (e.g., county lists of hydric soils, soil surveys, and aerial photography). That information can also be obtained from SCS State conservationists.

## Estimated Funding

The SCS spent \$6,143,000 on the wetland inventory in FY 89, and \$8,175,000 in FY 90. Inventory funds were allocated to SCS State offices based on the amount of wetlands identified as having a high potential for conversion and the State's expressed interest in conducting an inventory (Fig. 1). Some States supplemented the inventory funds provided nationally with general funding from FSA.

## Anticipated Future Activities

The SCS plans to continue the inventory for FY 91 but not beyond unless it becomes necessary to identify additional wetlands. For example, the next farm bill may call for the conversion of wetlands as the trigger for Swampbuster penalty, rather than planting a crop on converted wetland. Such a clause would require a more complete inventory because conversions for other purposes may include citrus, pasture, hayland, or other agricultural resources. The inventory now focuses on iden-

tifying only those areas that have high potential for conversion to annual crops.

## User Perspective

As previously discussed, the primary users of the SCS Wetland Inventory are USDA program participants and USDA program agencies. The inventory is produced with the various Swampbuster designations marked within each delineation to signify the restriction that is placed on the identified wetland or converted wetland

Table. Summary of use, maintenance, and improvements of various wetland designations.

Wetland designation	Use	Maintenance	Improvement
Prior Conversion (PC)—converted before 23 December 1985, but not abandoned	Produce agricultural commodities	Yes	Yes
Farmed wetland (FW)—still meets the wetland criteria, including seasonally ponded wetlands, seasonally flooded wetlands, potholes, and playas	May be farmed as it was before 23 December 1985	May maintain the degree of drainage that existed before 23 December 1985	None
Wetland (W)—includes natural conditions and abandoned wetlands	May be used to produce agricultural commodities when weather permits without removing woody vegetation	None	None
Commenced conversion (CC)	Same as prior conversion when completed	Yes	Yes
Third party	Produce agricultural commodities	May maintain the degree of drainage that existed as of date of third party action	None, unless determined by the Soil Conservation Service to have minimal effects
Converted wetland (CW)—converted after 23 December 1985	Production of agricultural commodities will cause a person to be ineligible for USDA benefits	None	None
Minimal Effect (MW)	Produce agricultural commodities	As per minimal effect agreement	As per minimal effect agreement
Artificial Wetland (AW)—including irrigation-induced wetland	Produce agricultural commodities	Yes	Yes

(Table). To date, the SCS has provided inventory information to very few other users. However, the inventory and related products (e.g., hydric soils lists, soil maps, and ASCS slides) are valuable tools for other agencies or interested parties who wish to make wetland determinations.

The SCS Wetland Inventory is designed primarily for FSA; therefore, users should be aware of its advantages and limitations. Because the SCS Wetland Inventory uses various tools and works from information available at a comparatively large scale, it is very detailed in the wetlands and converted wetlands it identifies. Generally, the SCS Wetland Inventory identifies more wetlands than other inventories. However, in most instances, the SCS Wetland Inventory identifies only FSA wetlands and converted wetlands. Other lands meeting wetlands criteria (e.g., artificial wetlands) may not be identified because of

FSA exemptions. Also, some wetlands are included in lands designated as "prior converted cropland." Such lands may be subject to other wetland laws or authorities even though they are exempt from FSA. Users should consult with SCS State conservationists before using the SCS Wetland Inventory to become aware of limitations of the inventory and to understand how FSA wetland and converted wetland designations were applied.

## Reference

- Federal Interagency Committee for Wetland Delineation. 1989. Federal manual for identifying and delineating jurisdictional wetlands. Cooperative technical publication of the U.S. Army Corps of Engineers, U.S. Environmental Protection Agency, U.S. Fish and Wildlife Service, and USDA Soil Conservation Service. Washington, D.C. 76 pp.

## Appendix. Prairie Soils Regions' Wetland Mapping Conventions for the 1985 Food Security Act (FSA)

---

### POTHOLES AND SATURATED - PRAIRIE SOILS (WISCONSIN GLACIATED REGION)

Wetlands will be inventoried using the following procedure which was developed to maintain consistency between field offices. This will be used as the basis for making office determinations of wetlands in the Prairie Pothole soils. It takes into consideration above normal and below normal precipitation years. The principal tools used to make the wetland inventory are: soil surveys, National Wetland Inventory (NWI) maps, black and white aerial photos, and ASCS color slides.

Step 1.---Review NWI maps where available. NWI maps will give an excellent overview of the wetlands in the area. All wetlands on the NWI maps will be considered wetlands for these conventions unless review of the ASCS slides fails to confirm the area as meeting wetland criteria. This could happen for the following reasons:

1. Review of the slides for all the years does not show pothole basins as having water, hydrophytic vegetation, drowned out crops. or crop color during abnormally dry or wet years.
2. The wetland has been drained since the NWI photos were taken. Look for manipulation such as ditches, new tile lines, dikes or levees.

**NOTE:** Many wetlands are excluded on NWI maps because of the Fish and Wildlife Service's Farmed Wetland Policy. The SCS state office may wish to contact the FWS regional wetland coordinator to get an overview of the NWI mapping conventions.

Step 2.---Review the soil survey. Review of the soil survey will help identify which areas of the field have potential for wetlands.

Is the site on a hydric soil map unit or on a map unit with hydric inclusions, or on any wet miscellaneous areas or spots symbols such as depressional areas, riverwash, and beaches, or on water areas that meet hydric water table, ponding, or flooding criteria? See Appendix for hydric soil criteria or NFSAM 512.10-512.12.

Step 3.---Review ASCS color slides (and color infrared if available) for the years 1981 to 1988 (when available). In most cases, 5-7 years will be available in most counties. Use Geological Survey or weather service climatological data in conjunction with the ASCS slides. Review the climatological data to determine those years which were above or below normal precipitation 2 to 3 months prior to the date of the slide. The slides were taken in late June or July. In most cases, flights were flown in July.

When reviewing slides, the following criteria are considered indicators of a wetland and will be marked.

1. Hydrophytic vegetation in the area.
2. Water or drowned out crop (mud flat).
3. Stressed crop production due to wetness (yellow).
4. Color of crop in dry or wet years (greener or yellow).
5. Differences in color due to different planting dates.

When viewing the slides, place a clear overlay on the Kodak caramate screen. Circle the wetlands with a dry erasable marker for the first year (view wettest year first) reviewed. Go to the next year slide, circle new wetlands, and place a checkmark by those wetlands that have reoccured. Repeat the process for all the years. The clear overlay is a good way to being the process. After using the conventions for a period of time, experience may allow the clear overlay to be dropped from the process. Always check for manipulation of the wetlands. Document manipulations! (See exhibit - Wetness History . . . - as an example of documentation.)

For 5 or more years of slides (see exhibit 1):

1 circle, no checks, and wetland is verified by NWI map, possible wetland, review weather data to make a determination. The NWI must be reviewed. If the area with 1 circle and no checks cannot be verified by NWI, the area is not a wetland.

1 circle and 1 check and verified by NWI area is a wetland. If area is not verified by NWI, area is a probable wetland, review weather records to help make the determination.

1 circle and 2 or more checks, area is wetland whether or not verified by NWI.

If area shows up on NWI map but does not show on any years of the ASCS slides, area is not a wetland. Check for wetland manipulations.

For 4 or less years of slides:

1 circle, no checks, and verified by NWI, area is wetland

1 circle and no checks, and not on NWI area is possible wetland, check weather records and prior manipulations to help make a decision.

1 circle and 1 or more checks, area is a wetland whether or not verified by NWI.

No circles or checks from ASCS slides and on NWI, area is a possible wetland, check weather records. A field check may be necessary.

**Step 4.**—The wetland boundaries will then be transferred to an ASCS 8 inch/mile map or other suitable base map (aerial photo). This transfer is

more accurately done by projecting the ASCS slide on the ASCS map and outlining the wetlands. The wetlands will be delineated and labeled with a "W." Converted Wetlands will be recorded with a "CW." Those potholes located in cropfields where drainage activities are evident before December 23, 1985, but have not completely drained the potholes and they still meet wetland criteria but are farmed, will be recorded on map as a Farmed Wetland "FW."

Undrained potholes in prairie soils with herbaceous wetland plants or wetlands farmed under natural conditions will be shown as a wetland "W."

Saturated Prairie Soils that meet wetland criteria, but have not been manipulated (except farmed under natural conditions), are wetlands "W."

Artificial wetlands "AW" may be difficult to determine with this process. Farmer information or an onsite visit may be necessary.

Step 5.--The district conservationist will review the wetlands inventory and any other pertinent information available. A field trip will be taken only if necessary to check questionable wetlands. The appropriate FSA wetlands determination will be documented on the official ASCS map (photo) and SCS-CPA-026. Pertinent supporting data will be added to the case file. Scope and effect of the existing drainage on farmed wetlands "FW" will be documented.

GUIDELINES FOR WETLAND DELINEATIONS

POTHOLES AND SATURATED - PRAIRIE SOILS

1. yes or no - Hydric soil
2. yes or no - Does wetland show up on NWI?
3. 0 = Circle wetland first year observed
4. ✓ = Checkmark for each subsequent year observed
5. Outline boundaries of wetland and enter symbol

**EXAMPLE:** Five (5) or more years of ASCS slides

#	HYDRIC SOILS	NWI	8"-mi B & W	ASCS SLIDES 81-88	STATUS
1	Yes	Yes	No	0 or X	Possible-Check weather records*
	No	No	No	0	None
2	Yes	No	Yes	0 ✓	Probable-Check weather records*
		Yes	Yes	0 ✓	Wetland
3	Yes	Yes	Yes	0 ✓✓	Wetland
	or No	or No	or No	or more ✓	

X = An X is used when team member has a question on a call. District conservationist needs to make decision. Not used often.

\*Field checks may be needed.



# Regional and Federal-State Cooperative Programs

---

## Coastal Mapping Programs at the U.S. Fish and Wildlife Service's National Wetlands Research Center

by

James B. Johnston and Lawrence R. Handley

*U.S. Fish and Wildlife Service  
National Wetlands Research Center  
1010 Gause Boulevard  
Slidell, Louisiana 70458*

**ABSTRACT.**—Over the past 10 years, the U.S. Fish and Wildlife Service's (FWS) National Wetlands Research Center (center; formerly the National Coastal Ecosystems Team) has been continuously involved in the production of maps for use by coastal decision makers. The types of maps produced by the center have been national, regional, or local in scope depending on user needs. Map scales have ranged from 1:24,000 to 1:250,000. Themes depicted have included biological resources, including wetlands and seagrasses; upland habitat or land use; water resources such as water quality, bathymetry, and salinity; cultural features such as ownership, archaeological sites, and dredge-spoil disposal areas; and soils and landforms. We present overviews on the various mapping programs of the center. We highlight efforts such as the ecological inventories of the Atlantic, Gulf, and Pacific coasts; the ecological characterization atlases of the Gulf of Mexico; and the large scale (1:24,000) habitat maps of various coastal regions of the United States. Center methods and techniques are discussed, including the collaborative efforts between the center and FWS's National Wetlands Inventory for updating wetland maps and adding upland and seagrass bed delineations to inventory maps. We also make recommendations for future coastal ecosystem mapping programs that use conventional and automated mapping methodologies, such as geographic information systems and image processing.

The National Wetlands Research Center (center) of the U.S. Fish and Wildlife Service (FWS) has an ongoing program in habitat mapping of wetlands and uplands. We cooperate with the National Wetlands Inventory (NWI), using its processes of photointerpretation, quality control and assurance, and distribution. We differ from NWI in mapping biological data and resources at other scales of 1:100,000 and 1:250,000, in adding upland habitat to the wetland maps, and in developing time-sequenced mapping for habitat trend analysis.

All of our mapping projects are developed as special interest programs (e.g., Louisiana land loss or seagrass mapping) in cooperation with other Federal and State agencies, such as the U.S. Army Corps of Engineers (COE), the U.S. Environmental Protection Agency (EPA), and the Louisiana Department of Natural Resources. Technical assistance is also provided from within FWS. We have added uplands to wetland maps and developed criteria for the incorporation of the additional upland categories. We have provided updates of hab-

itat maps that the center completed previously. From the sequential dates of mapping we can look at a trend analysis of habitat loss and gain. We use the Cowardin et al. (1979) classification system as the primary criteria for wetland delineation through the various systems, subsystems, classes, and subclasses. However, if additional information is available, we are able to add modifiers, which NWI is usually not able to do because data are not available. For example, for coastal Louisiana we are adding a salinity modifier on the habitat maps. Through additional coordination at the local level, we are able to gather this type of information for many of our special projects. We have completed a number of projects related to habitat mapping at the 1:24,000 scale. Coastal Louisiana was mapped for 1956, 1978, and 1988, with an update in 1983 for the lower Mississippi River Delta and the Terrebonne Marsh area. In 1985, we coordinated with the National Aeronautics and Space Administration (NASA) to produce aerial photography of coastal Louisiana. At that time, only 11 habitat maps were developed for the State of Louisiana to compare data with pre-Hurricane Juan satellite imagery. We mapped coastal Texas for 1956 and 1979, and mapped 10 quadrangles for 1983. We mapped habitats in coastal Mississippi in 1956 and 1979. For Alabama, 32 quads for the Mobile Bay area were completed for 1956 and 1979. For the west coast of Florida, we completed selected quads of the Panhandle area as well as 26 quads of Tampa Bay in the mid-1950's, 1962, and 1982. For San Francisco Bay, we completed 20 quads of the south bay for the mid-1950's, 1976, and 1985. For the north bay, an additional 24 quads were completed for 1976 and 1985; another 63 quads were completed for only 1985 for a surrounding area of the bay. These are most of the habitat mapping projects that we have completed with multiple year updates.

The upland classification that we use is patterned after Anderson et al.'s (1976) classification, which is used by the U.S. Geological Survey (USGS) in its land use mapping. However, the upland classification is gradually evolving, just as the wetland classification has changed over time. The upland classification we use is now commonly referred to as "the Handley upland classification" because we have gradually added more identifiers to the uplands, as the special projects dictate greater detail and varying needs.

Examples of these identifiers include urban forest, rangeland, agricultural, and barren lands,

as well as additional subcategory identifiers such as rice fields, parks, cemeteries, golf courses, spoil areas, and transportation corridors. The North American Waterfowl Management Plan suggests looking at rice fields as habitat for wintering ducks, and FWS is interested in the breakdown of forested land into scrub-shrub or evergreen, and deciduous forests as habitats suitable for red-cockaded woodpecker (*Picoides borealis*) nesting.

One of the great needs in habitat mapping is the addition of the upland classification to properly analyze and assess habitat changes and processes. In assessing the habitat changes for an area, it is difficult to understand "Where did the wetlands go?" if uplands are the only category. To understand the processes of change in the landscape, for example, it is necessary to know what type of uplands replaced the wetlands. Can one assume that wetlands were filled in or drained for urban development or could they have gone into upland agricultural land, rangeland, or forest? Around San Francisco Bay, with its wholesale development, it is assumed that any loss of wetlands went into the uplands category, but this is not always true. Finally, wetlands lose acreage to other wetland categories as the water regimes change.

The addition of the upland categories helps us understand the overall picture of habitat change in a particular area. In the San Francisco Bay, for example, wetlands certainly lost many acres, but the greatest loss of all occurred in upland agricultural land. The land of the market gardens, truck farming, and alfalfa around the San Francisco Bay lost almost four times as many acres as in the wetlands. The upland categories are very important, and the need is certainly present for the development of a comprehensive and systematic uplands classification system that will complement the existing wetlands classification.

We have developed projects to analyze habitat trends and changes. For example, in San Francisco Bay, we have put together a habitat change map for the mid-1950's, 1976, and 1985. We have done the same thing for the lower Mississippi Delta for 4 years (1956, 1978, 1983, and 1988). In addition, in several of our mapping projects we are developing the wetland maps to include selected indicator species. For example, in the lower Mississippi River Delta, we are adding a habitat modifier for two particular species—*Spartina alterniflora* (smooth cordgrass) and *Phragmites australis* (common reed). *Spartina* is primarily an indicator of salinity, and *Phragmites* an indicator of fresh or

brackish water. We are also interested in determining how much loss or gain has taken place for each species between 1978 and 1983, and between 1983 and 1987.

The mapping of the Chandeleur Islands is primarily seagrass mapping. We have photography from three dates (1978, 1982, and 1987) that has been interpreted for habitat. In addition, in 1990 we will interpret photos from April 1969, October 1969, November 1988, and June 1989. Also, we are acquiring aerial photography of the Chandeleur Islands on a quarterly basis to study seasonal variations in the seagrass cover. Although this project was undertaken originally in conjunction with other center studies on the redhead (*Aythya americana*) population that winters at the Chandeleur Islands, it has evolved into a seagrass photointerpretation study of its own.

The Louisiana Coastal Zone Project was performed for the State of Louisiana to update data following Hurricane Juan. Louisiana is using these habitat maps to compare with Landsat Thematic Mapper Simulator digital data acquired before Hurricane Juan to analyze the hurricane's effects on the breakup of marshes. In coastal Louisiana, we are also photointerpreting and mapping uplands and wetlands in 330 quads. This project will take about 3 years to complete. At present, we are in Phase I, which is the photointerpretation of 110 quads. Phase II and Phase III will be the completion of the photointerpretation of the remaining 220 quads over the next 2 years. This project will provide an update using 1988 photography to add to our existing 1956 and 1978 data bases of coastal Louisiana.

In Mobile Bay, Alabama, we are mapping 26 quads to update the 1956 and 1979 wetland maps. In the San Joaquin Valley, we are mapping 83 quads; 26 of these quads focus on uplands, and the other 57 are an update of wetlands and uplands. This mapping is for the San Joaquin Valley Drainage Program and will be used in analyzing the Kesterson National Wildlife Refuge selenium problem.

To show the overall aspects of some of these projects, we not only had the habitat maps for the San Francisco Bay Project for several dates, but we also developed two reports that provided an analysis of the habitat trends in the south bay and the north bay, a report on the comparison of fish and wildlife use of a natural marsh with an artificial marsh, and two large-format habitat maps of the bay area. The information produced in our trend analysis is being extensively used in the

bay's waterfowl management plan, by EPA's Estuarine Program assessments, in two court cases, by the California attorney general's office, and in at least a dozen other projects, programs, and studies.

Special projects completed or ongoing at the center, are generally done in the interest of FWS. In particular, we provide technical assistance to Fish and Wildlife Enhancement Offices, regional offices, or national wildlife refuges. For example, we are mapping seagrasses in Perdido Bay, in Florida and Alabama, for 1940, 1978, and 1987, for the Panama City Enhancement Office. On Eglin Air Force Base in Florida, we are developing ecological community maps for the U.S. Air Force and FWS to use in surveying red-cockaded woodpecker habitats for active colonies.

The information we have collected has been used to develop digital data bases that can be entered into the center's geographic information system (GIS) to implement natural resource inventories, habitat trend analyses, and cartographic modeling projects. We work with other Federal and State agencies in need of the habitat maps and the digital data to conduct their work. These other agencies include the National Park Service, COE, EPA, and Louisiana's Department of Natural Resources. We have developed a digital data base of the habitat maps for coastal Alabama, Louisiana, Mississippi, Texas, and portions of the Gulf Coast of Florida. In addition, we have digital data for other selected areas of the country including New Jersey, the lower Chesapeake Bay, the St. Lawrence Seaway, and the San Francisco Bay.

We have also been involved in the development of maps for atlases and inventories at scales of 1:100,000 and 1:250,000. In 1978, we began developing the first of the ecological atlases for regions of the Gulf Coast. In all, four atlases were developed: the Mississippi Deltaic Plain Atlas, the Texas Barrier Islands Regional Atlas, the Coastal Alabama Ecological Atlas, and the Florida Ecological Atlas. A fifth atlas, the Chenier Plain Ecological Atlas, is in progress; it will fill in the final gap along the Gulf Coast. The mapping for each of these atlases is completed on 1:100,000 USGS base maps. Five topics per map are displayed: biological resources, socioeconomic features, soils and landforms, oil and gas infrastructure, and climatology and hydrology. For each topic we accumulated a great deal of information from many resources in mapped form, text format, site visits, meetings with regional experts, and reviewers'

comments. The reports that were produced as part of these overall projects include bibliographies of biological and socioeconomic literature, information synthesis, map narratives, and some special reports on modeling efforts, ecological community profiles, and seagrass atlases. The Minerals Management Service, EPA, and various State agencies were instrumental in funding, collecting data, writing reports, and reviewing the atlases and reports.

The ecological inventories were completed by the center in 1984; they cover the Atlantic, Gulf and Pacific coasts, and the lower Mississippi Valley. The scale of the maps we used was 1:250,000; the maps included an inventory of a single topic—biological resources. Some resources we mapped are fish spawning areas, bird rookeries, bird nesting areas, endangered species habitats, major natural waterways, turtle nesting areas, and State and Federal wildlife refuges and management areas. The ecological inventory maps were conceived as aids to site planning of thermal power plants along the Atlantic Coast; their scale, however, made specific site planning difficult. Overall use has far overshadowed the deficit; these maps have become extremely valuable aids for regional environmental impact assessment and environmental analysis, oil spill risk assessment, oil spill sensitivity, and oil spill cleanup planning.

Several entities have developed products based on these maps. Resource Planning Institute of Columbia, South Carolina, an oil industry consultant, has developed a set of maps of the coastal United States; these maps deal with the sensitivity of particular coastal segments to oil spill cleanup activities. MERG, an oil industry consortium working through consultants such as Coastal Environmental, Inc., has developed sets of maps that delineate segments of the coastal United States that should be protected from oil spill impact on a priority basis. S.L. Ross of Canada has developed a computerized data base that many oil companies are using on microcomputers for oil spill risk assessment and oil spill cleanup.

All of these products have one major flaw—the data used to develop the maps. In particular, the biological resource information taken from the ecological inventory maps and ecological atlases is outdated and in some cases highly generalized. For example, the priority resources to be protected or cleaned may not be in those locations any longer. For instance, 35% of the Gulf Coast bird

rookeries and nesting sites have either disappeared or changed locations.

Representatives from oil companies and State and Federal agencies met on 7 December 1989 to discuss the need for a comprehensive, updated biological resources mapping program. Nationwide, the greatest need in thematic mapping is to update FWS's ecological inventory. One suggestion made by the center is that the 1:250,000-scale maps do not lend themselves well to detail for site-specific analysis, oil spill risk assessment, or digitizing. We propose that the ecological inventory be updated using the 1:100,000-scale USGS maps as the mapping base. The USGS 1:100,000 digital line graphs are completed for the country. By doing this we would provide additional theme overlays of political boundaries, hydrology, and of the transportation network. This scale of maps would provide a manageable and usable product that would be more meaningful to planners, environmental consultants, and analysts, and is more specific and detailed for oil spill cleanup, risk assessment, site planning, and permit analysis.

Another aspect of mapping the center provides is the coordination and organization of flights to acquire aerial photography and digital data over many areas. We organized a consortium of Federal and State agencies to provide the funding for a flight of coastal Louisiana, Mississippi, Alabama, and a portion of the western Florida Panhandle. These groups included FWS, EPA (Atlanta Region and Dallas Region), COE (New Orleans District and Mobile District), and the States of Alabama and Mississippi. Nearly 3,000 line-miles were flown resulting in the collection of 1,000 colorinfrared photographs at 1:65,000 scale, and airborne Thematic Mapper Simulator (TMS) digital data. The coastal Louisiana, Mississippi, and Alabama flights were completed between 6 November 1988 and 30 March 1989. Because of the success of this flight, we were asked to organize a similar group to fund a flight of coastal Texas for the fall of 1989. This consortium included FWS, EPA (Dallas Region), COE (Galveston District), and the Soil Conservation Service. The coastal Texas flight, flown by NASA out of Ames Research Center at Moffett Field, California, encompassed about 3,000 flight-line miles, took a thousand 1:65,000-scale color-infrared photographs, and collected TMS digital data. The Texas coast was flown between 27 November and 15 December 1989.

## References

- Anderson, J. R., E. E. Hardy, J. T. Roach, and R. E. Witmer. 1976. A land use and land cover classification system for use with remote sensor data. U.S. Geol. Surv. Prof. Pap. 964. 28 pp.
- Cowardin, L. M., V. Carter, F. C. Golet, and E. T. LaRoe. 1979. Classifications of wetlands and deepwater habitats of the United States. U.S. Fish Wildl. Serv., FWS/OBS-79/31. 103 pp.

# Monitoring Seagrass Distribution and Abundance Patterns: A Case Study from the Chesapeake Bay<sup>1</sup>

by

Robert J. Orth, Kenneth A. Moore, and Judith F. Nowak

*Virginia Institute of Marine Science  
School of Marine Science  
College of William and Mary  
Gloucester Point, Virginia 23062*

**ABSTRACT.**—Seagrasses, or submerged aquatic vegetation (SAV), have been mapped in the Chesapeake Bay five times between 1978 and 1987 with standard aerial photographic techniques, resulting in annual reports on SAV distribution. Acquisition of the vertical photography at a scale of 1:24,000, adhering to strict quality-assurance guidelines based on sun angle, tidal stage, cloud cover, wind speed, and season, has produced excellent, high-contrast imagery delineating beds of SAV from adjacent, unvegetated areas. Ground-truthing data from various State, Federal, and public organizations have corroborated the photographic data base. Digitized bed outlines resulting from photointerpretation of the imagery onto 1:24,000-U.S. Geological Survey topographic quadrangles have been stored on a Virginia Institute of Marine Science geographic information system (GIS). A report summarizing the photographic and ground survey data is produced each year. Results from these surveys have shown distinct changes in the distribution and abundance of SAV in different areas in the bay over the last 10 years. The amount of SAV has increased 21% from 1978 to 1987 with some areas showing rapid increases in less than 5 years. The success of these annual surveys in the Chesapeake Bay indicates that aerial photographic techniques can be used to delineate spatial and temporal patterns of seagrass communities, as well as those communities comprised of brackish-water species. Appropriate GIS systems can be employed to assess historical trends at any location.

Seagrasses are submersed vascular plants found in shallow-water coastal and estuarine environments throughout the world. There are about 50 species growing in a wide variety of sediments from the intertidal zone to depths of 10 m. In turbid estuarine environments, such as the Chesapeake Bay, seagrasses are not found at depths below 2 m at mean low water (MLW), whereas in less turbid areas, such as the Caribbean Sea, seagrasses can be found at depths of 50 m or more.

Seagrasses, like their emergent wetland counterparts, serve many different functions. Because they baffle currents and stabilize sediments, extensive seagrass beds adjacent to shorelines can reduce shoreline erosion. Seagrass beds support

dense assemblages of vertebrates and invertebrates and often serve as nursery areas for many commercially important species, such as the bay scallop, *Aequipectin irradians*. Seagrass meadows are important in nutrient cycling between sediments and the overlying water, and they contribute to the detrital food chain. Only a few groups of animals (e.g., geese, dugongs, manatees) actually consume seagrasses; however, the attached epiphytes are food for invertebrates (e.g., gastropods, amphipods), which in turn are food for secondary consumers.

In the continental United States, seagrasses are present in every coastal State except Delaware, Georgia, and South Carolina, although quantitative estimates on distribution and abundance in many States are generally lacking. Table 1 presents a summary of data currently available on the abundance of seagrasses as compared with total area of salt marsh. Seagrass coverage in many

<sup>1</sup> Contribution No. 1576 from the Virginia Institute of Marine Science, Gloucester Point, Virginia 23062.

Table 1. *Salt marsh and seagrass coverage (hectares) by State<sup>a</sup> (modified from Orth and van Montfrans 1990). No data are available for seagrasses in those coastal States not listed.*

State	Salt marsh (reference <sup>b</sup> )	Seagrass (reference <sup>b</sup> )
New York	10,810 <sup>1</sup>	78,100 <sup>10</sup>
New Jersey	83,989 <sup>2</sup>	12,624 <sup>1,11</sup>
Delaware	26,183 <sup>3</sup>	0
Virginia-Maryland	145,813 <sup>3,4</sup>	17,353 <sup>12</sup>
North Carolina	64,291 <sup>1</sup>	80,972 <sup>13</sup>
South Carolina	149,580 <sup>5</sup>	0
Georgia	151,538 <sup>1</sup>	0
Florida-Atlantic Coast	38,826 <sup>1</sup>	2,800 <sup>14</sup>
Florida-Gulf Coast	137,455 <sup>6,7c</sup>	913,700 <sup>14</sup>
Alabama	11,855 <sup>8</sup>	12,300 <sup>14</sup>
Mississippi	24,919 <sup>9</sup>	2,000 <sup>14</sup>
Louisiana	720,648 <sup>9</sup>	4,100 <sup>14</sup>
Texas	174,899 <sup>6</sup>	68,500 <sup>14</sup>

<sup>a</sup> Wetland areas identified as containing salt-tolerant vegetation (categorized as "salt marsh" or "nonfresh" in data reports or published papers) were used and listed in the totals above.

<sup>b</sup> 1, Field et al. 1988; 2, Tiner 1985a; 3, Tiner 1985b; 4, Silberhorn, Virginia Institute of Marine Science, personal communication; 5, Tiner 1977; 6, Reyer et al. 1988; 7, Perry 1984; 8, Roach et al. 1987; 9, E. C. Pendleton, U.S. Fish and Wildlife Service, personal communication; 10, Macomber and Allen 1979; 11, Dennison, et al. In press; 12, Orth et al. 1989; 13, Ferguson et al. 1988; 14, Iverson and Bittaker 1986.

<sup>c</sup> Includes 34,540 ha of mangroves listed in Perry 1984.

States may be underestimated because of the lack of quantitative mapping studies. Seagrass monitoring programs are rare because of the inherent technical difficulties and cost in censusing these underwater populations (Orth and Moore 1983a). Some seagrass beds have been mapped successfully with remote-sensing techniques such as low-level or satellite photography, or through field surveys including transects or randomized sampling (Orth and Moore 1983a; Walker 1989). However, most State and Federal agencies have focused their efforts on emergent wetlands. The U.S. Fish and Wildlife Service's National Wetlands Inventory is one such mapping effort.

In recent decades, seagrass declines have occurred worldwide (Kemp et al. 1983; Orth and Moore 1983b; Cambridge and McComb 1984; Neverauskas 1987). The magnitude of these losses, in many cases, has been difficult to assess because of inadequate data on distribution and abundance patterns before the decline. Monitor-

ing seagrass distribution and abundance is critical for making quantitative assessments of losses, thereby increasing our understanding of factors controlling growth and distribution.

## Development of a Seagrass Monitoring Program: A Case Study of Chesapeake Bay

A decline of seagrass and brackish-water species throughout Chesapeake Bay in the late 1960's and 1970's (Kemp et al. 1983; Orth and Moore 1983b, 1984) led the U.S. Environmental Protection Agency to initiate a major research program in 1978. This program determined the distribution and abundance of submersed bay grasses and the factors that contributed to their decline. The greatest loss of vegetation occurred in the upper and middle sections of the bay and tributaries (Fig. 1). The results of the studies indicated that nutrient enrichment and high levels of turbidity were associated with the declines in a number of areas (Kemp et al. 1983).

A 1987 agreement signed by the governors of Maryland, Pennsylvania, and Virginia, and the mayor of Washington, D.C., committed the States to develop management policies for the living resources of the bay. A committee of Federal, State, and university scientists and managers developed a management policy to protect, enhance, and restore seagrass and brackish-water species (collectively referred to as submerged aquatic vegetation or SAV) in the bay. This policy was approved and signed in July 1989. An implementation plan for the SAV management policy is being developed by the committee.

Surveys of SAV and brackish-water species have revealed several large changes in distribution and abundance over a short time. Therefore, one requirement of the SAV management policy is to develop a monitoring program that will annually determine the distribution and abundance of SAV. This program will be implemented by using low-level, vertical aerial photographs and ground surveys. This survey methodology was developed over a 10-year period in Chesapeake Bay. In aerial photographs, seagrasses—under appropriate environmental conditions—generally have a signature distinct from adjacent, unvegetated areas. Aerial photographs also provide a synoptic view of baywide patterns for future analysis. The first baywide survey to use low-level, vertical aerial

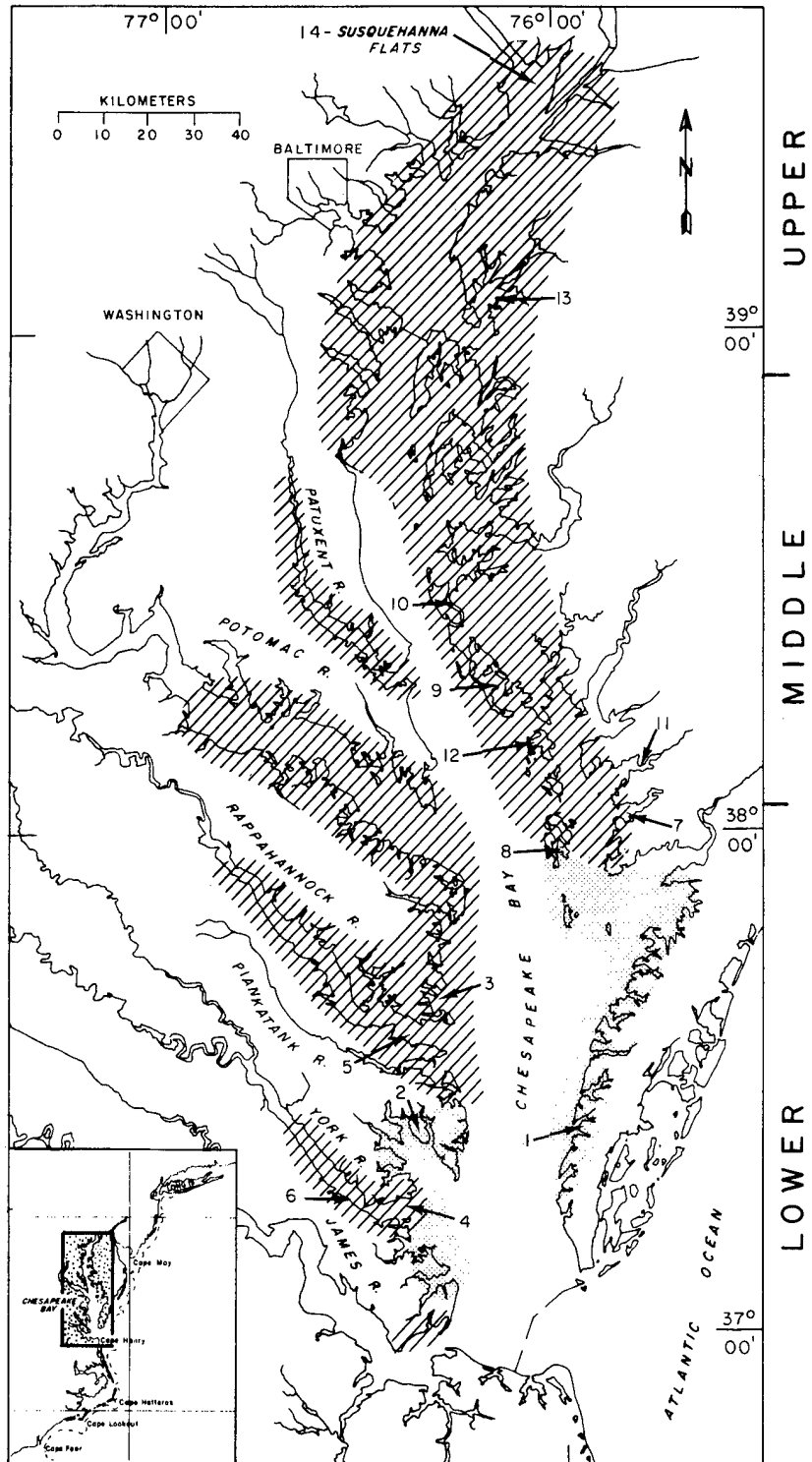

**Fig. 1.** Chesapeake Bay and tributaries showing major declines of submerged aquatic vegetation (SAV; crosshatched area) during the 1960's and 1970's, and showing areas where SAV was still abundant (stippled area; reprinted with permission of Science; see Orth and Moore 1983b).



photography was conducted in 1978 (Orth et al. 1979; Anderson and Macomber 1980). Subsequent baywide surveys were conducted in 1984-87 and 1989 with the same methodology (Orth et al. 1985, 1986, 1987, 1989). Additional aerial surveys were conducted in the lower bay in 1974, 1980, and 1981, and historical aerial photographs were used to map the lower western shore in 1971 (Orth and Gordon 1975).

## Submerged Aquatic Vegetation Species

Ten SAV species are commonly found in the Chesapeake Bay and its tributaries. The limits of a species' distribution are determined by its salinity tolerance (Orth and Moore 1981). *Zostera marina* (eelgrass), tolerant of salinities as low as 10 ‰, is abundant in the lower portion of the bay. *Myriophyllum spicatum* (water milfoil), *Potamogeton pectinatus* (sago pondweed), *Potamogeton perfoliatus* (redhead grass), *Zannichellia palustris* (horned pondweed), *Elodea canadensis* (common

elodea), *Ceratophyllum demersum* (coontail), *Najas guadalupensis* (southern naiad), and *Vallisneria americana* (wild celery) are less tolerant of high salinities and are found in the middle and upper sections of the bay and tributaries. *Ruppia maritima* (widgeon grass) is tolerant of a wide range of salinities and is found throughout the bay. About 11 other species are occasionally found in the middle and upper reaches of the bay and tidal rivers (Table 2). *Hydrilla verticillata* (hydrilla) was introduced into the Potomac River in 1981 and rapidly became abundant in the tidal freshwater section.

## Aerial Photography and Ground Truthing

SAV photographs are obtained by using standard aerial mapping cameras, with either black and white or color film (both film types have been used effectively in the monitoring program). Photographs are taken at an altitude of about 12,000 feet, yielding a 1:24,000 photographic scale. Coverage includes all areas known to have SAV and areas that could potentially support SAV (i.e.,

Table 2. Species of submerged aquatic plants found in Chesapeake Bay and tributaries (from Orth et al. 1989).

Family	Species	Common name
Characeae (muskgrass)	<i>Chara braunii</i>	Muskgrass
	<i>Chara zeylanica</i>	
	<i>Nitella flexilis</i>	
Potamogetonaceae (pondweed)	<i>Potamogeton perfoliatus bupleuroides</i>	Redhead grass
	<i>Potamogeton pectinatus</i>	Sago pondweed
	<i>Potamogeton crispus</i>	Curly pondweed
	<i>Potamogeton pusillus</i>	Slender pondweed
	<i>Ruppia maritima</i>	Widgeon grass
	<i>Zannichellia palustris</i>	Horned pondweed
	<i>Zostera marina</i>	Eelgrass
Najadaceae	<i>Najas guadalupensis</i>	Southern naiad
	<i>Najas gracillima</i>	Naiad
	<i>Najas minor</i>	Naiad
Hydrocharitaceae (frogbit)	<i>Vallisneria americana</i>	Wild celery
	<i>Elodea canadensis</i>	Common elodea
	<i>Egeria densa</i>	Water-weed
	<i>Hydrilla verticillata</i>	Hydrilla
Pontedariaceae (pickerelweed)	<i>Heteranthera dubia</i> (= <i>Zosterell dubia</i> )	Water stargrass
Ceratophyllaceae (coontail)	<i>Ceratophyllum demersum</i>	Coontail
Trapaceae	<i>Trapa natans</i>	Water chestnut
Haloragaceae (water milfoil)	<i>Myriophyllum spicatum</i>	Eurasian water milfoil

generally all areas where water depths are less than 2 m at MLW), as well as land control points.

Survey flight lines are prioritized by area and are flown when the standing crop for the dominant species is at its peak. General guidelines governing mission planning and execution have been established; these guidelines address tidal stage, plant growth, turbidity, sun elevation, wind, water and atmospheric transparency, sensor operation, and plotting (Table 3). These guidelines ensure that photographs will be obtained during optimal conditions for detecting SAV, thus aiding accurate photointerpretation.

Field surveys of SAV communities are done by a number of State and Federal agencies and persons in Maryland and Virginia, including the U.S. Geological Survey (USGS), Maryland Department of Natural Resources, and Chesapeake Bay Foundation. Some surveys are conducted independent of the aerial mapping program; these include those surveys associated with SAV restoration programs in Maryland and Virginia, whereas other surveys support the aerial survey by checking SAV beds that were mapped the previous year. All data are synthesized in a report of the annual mapping program.

### *Mapping Process*

The USGS's 7.5-min topographic quadrangles are used as a basis for mapping SAV beds from aerial photography, digitizing SAV beds, and compiling SAV bed-area measurements (Fig. 2). Photointerpretation of SAV beds requires all available information, including knowledge of distinct aquatic grass signatures on film, ground surveys, and low-level aerial reconnaissance surveys. Delineation of boundaries of SAV beds onto topographic quadrangles is done by superimposing the appropriate mylar quadrangle onto the appropriate photograph. A best fit is obtained where minor scale differences are evident between the photograph and the mylar quadrangle. Shoreline changes are noted on the quadrangle if significant shoreline erosion or accretion has occurred since USGS publication of a map.

In addition to delineating the boundaries of the SAV bed, the percent of cover within each bed is estimated by using an enlarged crown-density scale similar to that developed for estimating forest crown cover. Bed density is classified into one of four categories based on a subjective comparison with the density scale. Either the entire bed, or subsections within the bed, are assigned a num-

Table 3. *Guidelines followed during acquisition of aerial photographs.*

---

**Tidal stage**—Photography is acquired at low tide,  $\pm$  0–1.5 feet, depending on overall water clarity and tidal regime of the area, as predicted by the National Ocean Survey tables.

**Plant growth**—Growth stages must ensure maximum delineation of SAV, and when phenologic stage overlap should be greatest.

**Sun angle**—Surface reflection from sun glint must not cover more than 30% of frame. Sun angle should be between 20° and 40° to minimize water surface glitter. At least 60% line overlap and 20% side lap are used to minimize image degradation due to sun glint.

**Turbidity**—Clarity of water must ensure complete delineation of grass beds. This is visually determined from the airplane to ensure that SAV could be seen by the observer.

**Wind**—Photography is acquired during periods of no wind or low wind. Offshore winds are preferred over onshore winds when wind conditions cannot be avoided.

**Atmospherics**—Photography is acquired during periods of no haze or low haze or clouds below aircraft. There should be no more than scattered or thin broken clouds, or thin overcast above aircraft, to ensure maximum SAV-to-bottom contrast.

**Sensor operation**—Photography is acquired in the vertical mode with 5° tilt. Scale/altitude/film/focal length combination must permit resolution and identification of about 1 m<sup>2</sup> area of SAV (surface).

**Plotting**—Each flight line includes sufficient identifiable land area to ensure accurate plotting of grass beds.

---

ber (1 = very sparse or <10% coverage; 2 = sparse or 10–40% coverage; 3 = moderate or 40–70% coverage; 4 = dense or 70–100% coverage) corresponding to the density categories. Additionally, each distinct SAV unit is assigned a two-letter designation unique to the map. Subsections of beds are further identified as being part of a contiguous bed by the addition of a code unique to that bed.

### *SAV Perimeter Digitization and Area Calculation*

The perimeters of all SAV beds mapped from aerial photographs are digitized using a Numonics

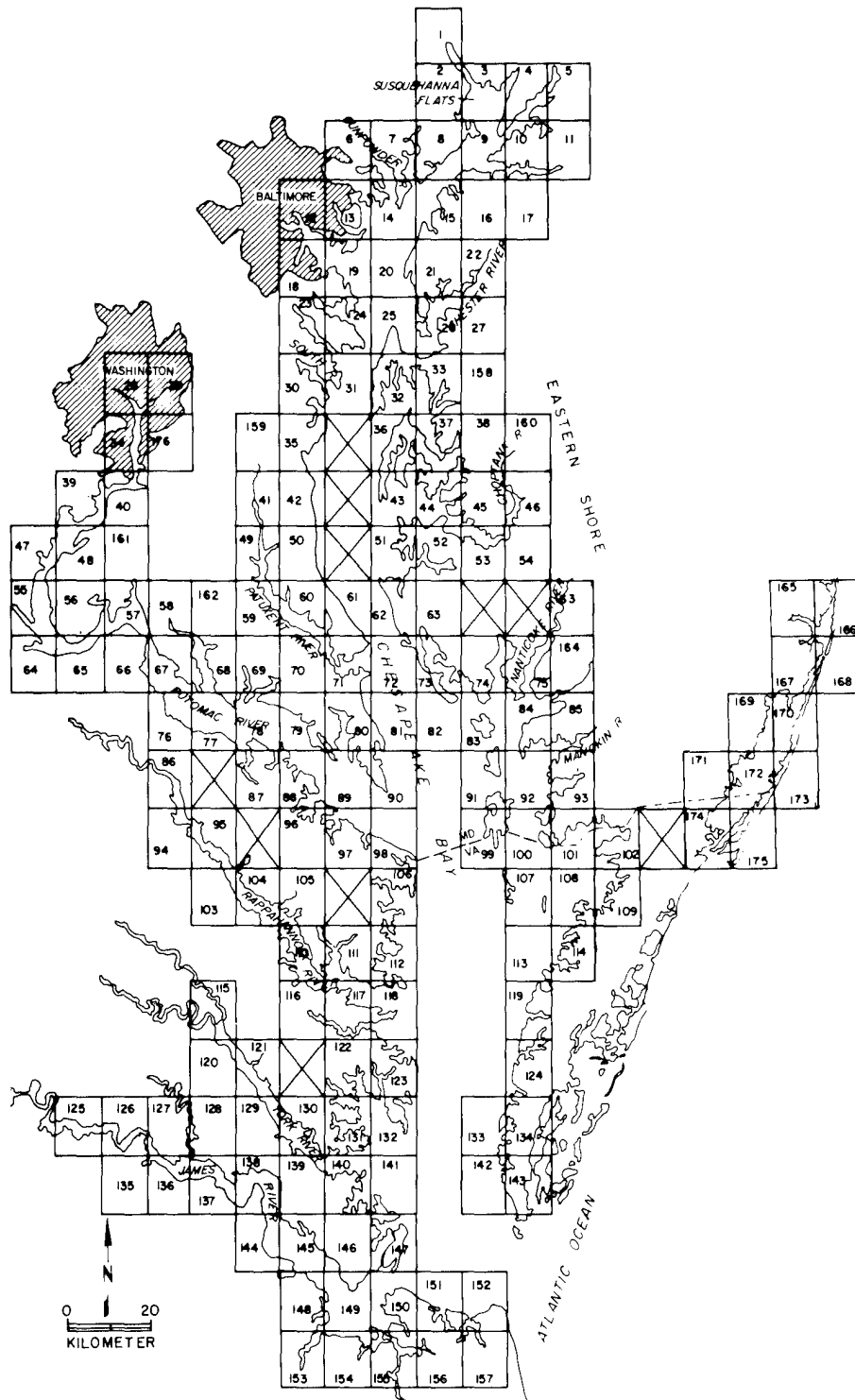

Fig. 2. Chesapeake Bay—locations of topographic quadrangles used in submerged aquatic vegetation monitoring program.

Model 2400/2200 Digitablet Graphics Analysis System with a resolution of 0.00254 cm and an accuracy of 0.0127 cm. Coordinates are transmitted to a PRIME 9955 computer for area calculation and data manipulation with a software program developed at the Virginia Institute of Marine Science. The area of each bed is reported as a mean of three trials. The range of these three trials is not to deviate from the mean by more than 5%.

The perimeter of each SAV bed is defined by a polygon with a linear point density of 50 per chart centimeter (5 m ground resolution). The total number of points defining any SAV bed is dependent on overall bed size. The SAV bed perimeter is stored as X and Y coordinates in centimeters from the quadrangle origin. Perimeters are later converted to latitude and longitude.

A standard operating procedure was developed to aid orderly and efficient processing of data, and to comply with the need for consistency, quality assurance, and quality control. These standard operating procedures include a detailed procedure outlining 46 steps for digitization of SAV maps; a 47-step checklist for editing SAV perimeter computer files; a digitizer log in which all operations are recorded and dated, and which is used to guide and record editing operations; and a flowchart used to track progress of all computer operations, including all changes in file names.

## Vegetation Trends in Chesapeake Bay

The distribution of SAV in the Chesapeake Bay and tributaries has been organized into 3 zones and 21 sections (Fig. 3). In 1978, the first baywide survey of seagrasses delineated 16,894 ha with 17.8, 44.0, and 38.2% in the upper, middle, and lower bay zones, respectively (Fig. 4). By 1987, there were 20,230 ha, a 21% increase from 1978, with 14.6, 45.9, and 39.2% in the upper, middle, and lower bay zones, respectively. From 1978 to 1987, there were relatively small changes in most sections of the lower bay zone, and both increases and decreases in sections of the middle and upper bay zones (Fig. 5). The increases were primarily in the upper Potomac River (section 11) and the middle reaches of the bay along the eastern shore (sections 12 and 13). Decreases were in the upper reaches of the bay (sections 3, 4, 5, 6, and 7). Data are not available for seagrass abundance in the bay before 1978, making it difficult to estimate the

amount of SAV that had been lost in the Chesapeake Bay up to that time. Qualitative assessments indicated that there may have been in excess of 50,000 ha, at peak levels (Bayly et al. 1978). Thus, current SAV populations may be less than half of those that existed 20 years ago. Several areas exemplify the changes described previously and are discussed in more detail to provide an additional perspective on the changes that have occurred in the bay.

The lower eastern shore (section 14) has had abundant seagrass since 1978 (Fig. 6). *Zostera marina* and *Ruppia maritima* are the dominant species in this area. Because this area is close to the mouth of the Chesapeake Bay, the generally less turbid water apparently allows for a much greater depth penetration of light and thus a greater depth distribution of SAV as compared with western shore areas (Orth and Moore 1988a).

Seagrass in the Rappahannock River (section 16), which consists of *Zostera marina* and *Ruppia maritima*, was abundant along both shores in 1971. There was a rapid decline in seagrass between 1971 and 1974, with continued absence of SAV through 1986. However, since 1987 there has been a rapid increase of *R. maritima* in some downriver areas (Fig. 7). This change has paralleled similar increases observed with this species in other mid-bay areas.

Submerged vegetation in the upper Potomac River was absent in 1978. However, a rapid increase was observed in 1984, with continuing expansion through 1987 (Fig. 8). The abundance in 1987 was the most recorded since the early 1900's and was largely due to the rapid spread of *Hydrilla verticillata*, after its accidental introduction in 1981. Although *H. verticillata* is by far the most dominant species in this region, 12 other species have been reported. The reason for their reoccurrence is unknown, but may be associated with the increase in water clarity created by the dense mats of *H. verticillata* in inshore areas. The increase in submerged vegetation in the upper Potomac River may have been accelerated because of the reduction in the discharge of nutrients by the Blue Plains Sewage Treatment Plant in Washington, D.C. Total suspended solids and phosphate loading have declined. Nitrification began in 1983, changing the main nitrogen input from ammonia to nitrate. Although no definite links between nutrient reductions and seagrass regrowth in this region have been made, these changes in discharge could only have had positive effects.

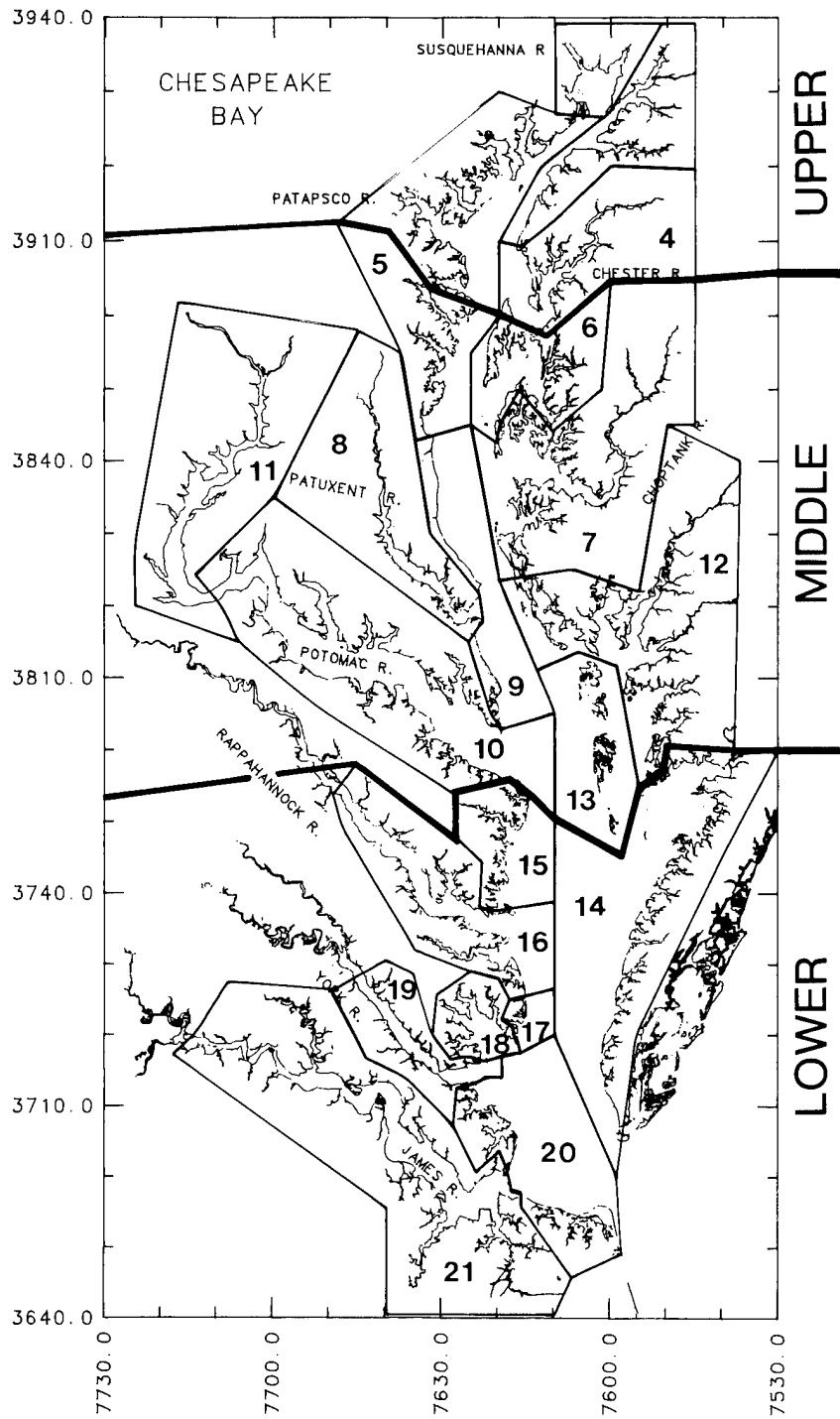

**Fig. 3.** Chesapeake Bay and tributaries showing delineation of zones (3) and sections (21) developed for discussion of trends of submerged aquatic vegetation.

### SAV Abundance in the Chesapeake Bay

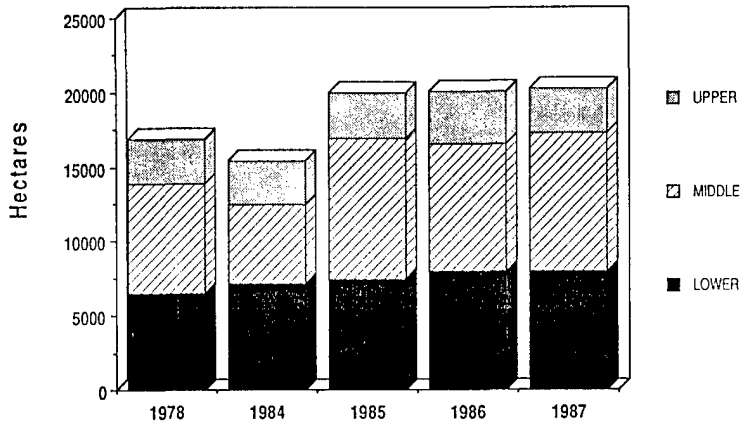

Fig. 4. Abundance of submerged aquatic vegetation by zone for the Chesapeake Bay and tributaries for 1978, and 1984 through 1987.

### Summary and Recommendations

Submerged vegetation in the Chesapeake Bay and its tributaries has been an abundant natural resource and, in some sections, it still is. Populations that experienced rapid declines in the 1970's have had some recovery in the 1980's. The recovery in some sections has been substantial and may be due to the improved water quality from reduced upland input of nutrients and sediments. However, large areas of the bay still have the potential to support seagrass populations. Thus, nutrient reduction strategies, including point and nonpoint

sources and groundwater inputs as well as reduction in sediment inputs, must be expanded if seagrasses are to remain a part of the Chesapeake Bay's important living resources (Orth and Moore 1988b).

Because of the importance of seagrasses to coastal estuaries and lagoons of the United States, and because of their vulnerability to changes in water quality, we recommend that a major initiative be undertaken to census this resource on a nationwide basis, as is ongoing in the Chesapeake Bay. For most areas we recommend that a combination of low-level aerial photography, flown under strict guidelines, and ground-truth studies, including permanent transects, be established to

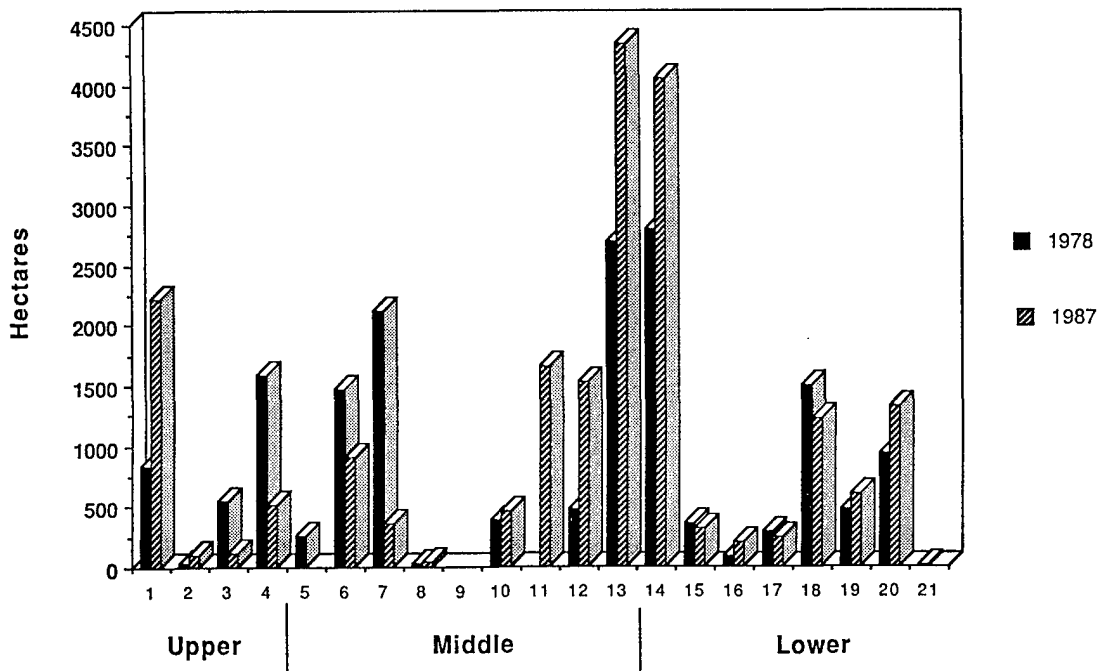
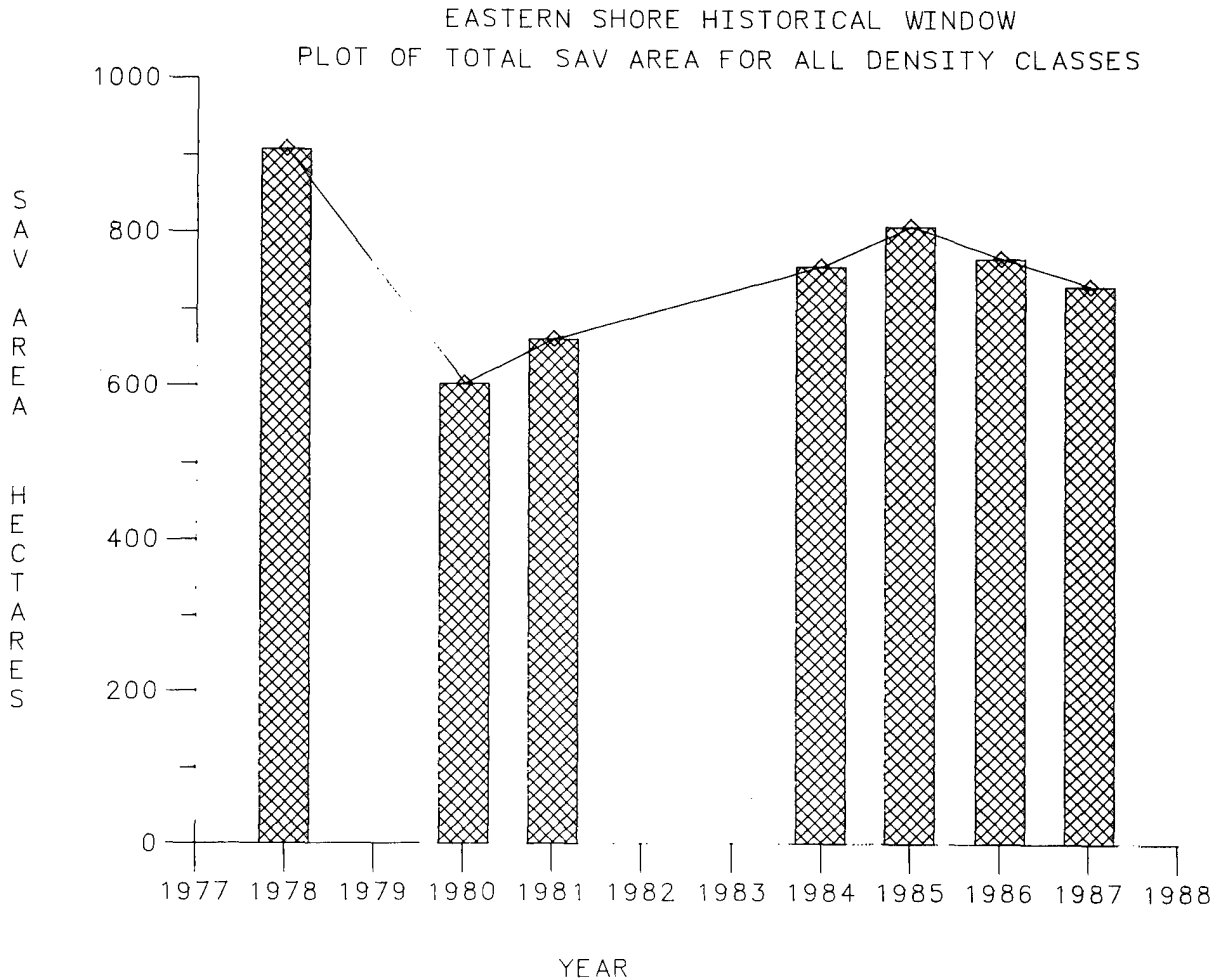

Fig. 5. Abundance of submerged aquatic vegetation for the 21 bay and tributary sections for 1978 and 1987.



**Fig. 6.** Abundance of submerged aquatic vegetation (SAV) for a portion of the lower eastern shore of Virginia (section 14), 1978–87.

examine long-term changes in species density and composition. Some regions (e.g., Florida), because of the extent of the seagrass beds, may require high-altitude or satellite photography. However, these baseline data are critical for the proper management of this resource, regionally as well as nationally. A coordinated, cooperative program between Federal and State agencies, in which standardized methods are used, will not only allow an assessment of the changes in distribution and abundance at these different levels, but also will protect existing resources.

### Acknowledgments

The monitoring program for SAV in the Chesapeake Bay would not have been possible without

the cooperation and financial support of many State and Federal organizations over the past 10 years. These organizations include the U.S. Environmental Protection Agency, National Oceanic and Atmospheric Administration's Coastal Zone Management Program, Maryland Department of Natural Resources, U.S. Army Corps of Engineers, U.S. Fish and Wildlife Service, the Committee to Preserve Assateague Island, and Allied-Signal, Inc. We especially thank R. Batiuk of the U.S. Environmental Protection Agency's Chesapeake Bay Liaison Office, for his continuing encouragement, and A. Frisch, who has made significant contributions to ensure the quality of the data management. H. Neckles provided valuable comments on the initial draft.

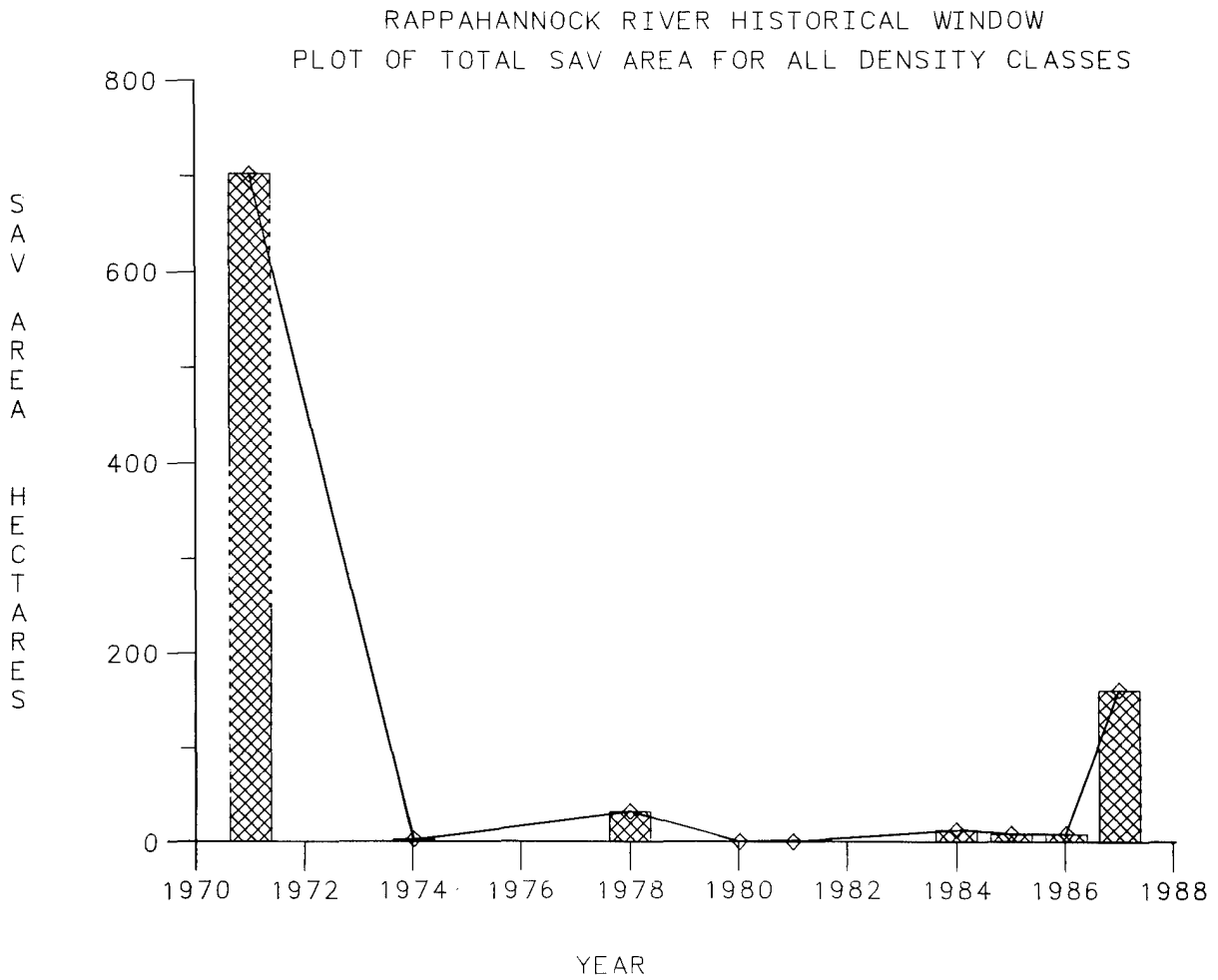

Fig. 7. Abundance of submerged aquatic vegetation (SAV) for the lower Rappahannock River (section 6), 1971-87.

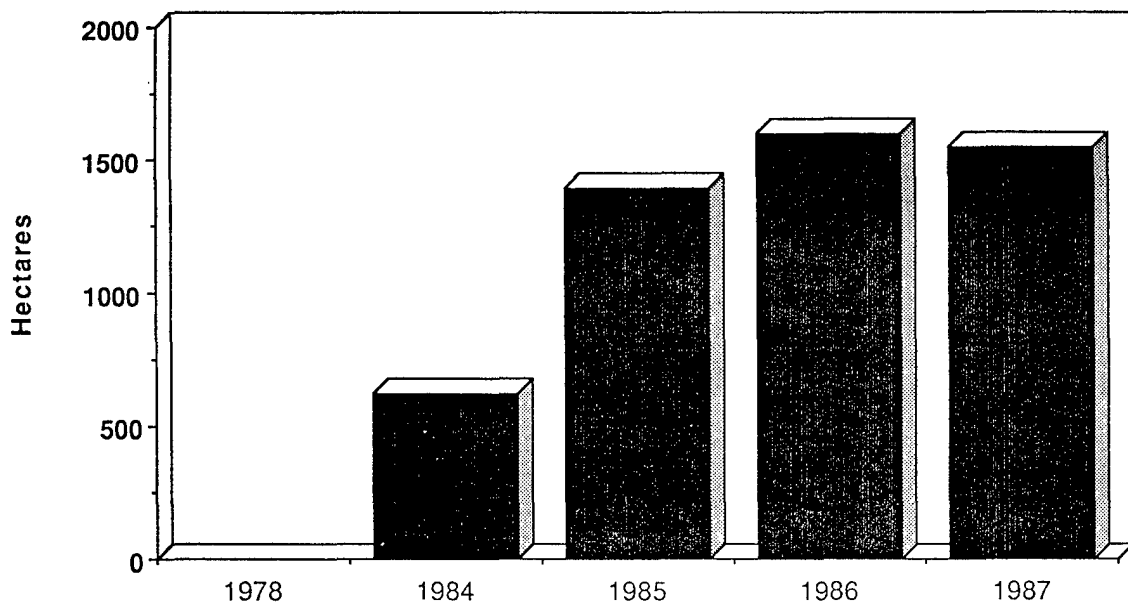

Fig. 8. Abundance of submerged aquatic vegetation for the upper Potomac River area (section 11), 1978-87.



## References

- Anderson, R. R., and R. T. Macomber. 1980. Distribution of submersed vascular plants in Chesapeake Bay, Maryland. Final report. U.S. Environmental Protection Agency, Chesapeake Bay Program, Grant R805970. 126 pp.
- Bayly, S., V. D. Stotts, P. F. Springer, and J. Stennis. 1978. Changes in submerged aquatic macrophyte populations at the head of the Chesapeake Bay—1958–1975. *Estuaries* 1:74–85.
- Cambridge, M. L., and A. J. McComb. 1984. The loss of seagrass from Cockburn Sound, western Australia. I. The time course and magnitude of seagrass decline in relation to industrial development. *Aquat. Bot.* 20:229–243.
- Dennison, W. C., G. Marshall, and C. Wigand. 1990. Effect of "brown tide" shading on eelgrass (*Zostera marina* L.) distribution. Lecture notes in coastal estuarine studies. In press.
- Ferguson, R. L., J. A. Rivera, and L. L. Wood. 1988. Submerged aquatic vegetation in the Albermarle-Pamlico estuarine system. Final report. National Marine Fisheries Service, National Oceanic and Atmospheric Administration, Beaufort Laboratory, Beaufort, N. C. 68 pp.
- Field, D. W., C. E. Alexander, and M. Broutman. 1988. Toward developing an inventory of U.S. coastal wetlands. *Mar. Fish. Rev.* 50:40–46.
- Iverson, R. L., and H. F. Bittaker. 1986. Seagrass distribution and abundance in eastern Gulf of Mexico coastal waters. *Estuarine Coastal Shelf Sci.* 22:577–602.
- Kemp, W. M., W. R. Boynton, R. R. Twilley, J. C. Stevenson, and J. C. Means. 1983. The decline of submerged vascular plants in upper Chesapeake Bay: summary of results concerning possible causes. *Mar. Tech. Soc. J.* 17:78–89.
- Macomber, R. T., and D. Allen. 1979. The New Jersey submerged aquatic vegetation distribution atlas. Final report. New Jersey Department of Environmental Protection. 25 pp.
- Neverauskas, V. P. 1987. Monitoring seagrass beds around a sewage sludge outfall in South Australia. *Mar. Pollut. Bull.* 18:158–164.
- Orth, R. J., A. A. Frisch, J. F. Nowak, and K. A. Moore. 1989. Distribution of submerged aquatic vegetation in the Chesapeake Bay and tributaries and Chincoteague Bay—1987. Final report. U.S. Environmental Protection Agency. 260 pp.
- Orth, R. J., and H. H. Gordon. 1975. Remote sensing of submerged aquatic vegetation in the lower Chesapeake Bay. Final report. National Aeronautics and Space Administration. Contract NAS1-10720. 62 pp.
- Orth, R. J., and K. A. Moore. 1981. Submerged aquatic vegetation of the Chesapeake Bay: past, present and future. Pages 271–283 in *Transactions of the 46th North American wildlife natural resources conferences*.
- Orth, R. J., and K. A. Moore. 1983a. Submersed vascular plants: techniques for analyzing their distribution and abundance. *Mar. Tech. Soc. J.* 17:38–52.
- Orth, R. J., and K. A. Moore. 1983b. Chesapeake Bay: an unprecedented decline in submerged aquatic vegetation. *Science* 222:51–53.
- Orth, R. J., and K. A. Moore. 1984. Distribution and abundance of submerged aquatic vegetation in Chesapeake Bay: an historical perspective. *Estuaries* 7:531–540.
- Orth, R. J., and K. A. Moore. 1988a. Distribution of *Zostera marina* L. and *Ruppia maritima* L. sensu lato along depth gradients in the lower Chesapeake Bay, U.S.A. *Aquat. Bot.* 32:291–305.
- Orth, R. J., and K. A. Moore. 1988b. Submerged aquatic vegetation in the Chesapeake Bay: a barometer of bay health. Pages 619–629 in M. Lynch, ed. *Understanding the estuary: advances in Chesapeake Bay Research*. Chesapeake Res. Consort. Publ. 129. CBP/TRS/24/88.
- Orth, R. J., K. A. Moore, and H. H. Gordon. 1979. Distribution and abundance of submerged aquatic vegetation in the lower Chesapeake Bay, Virginia. Final report. U.S. Environmental Protection Agency, Chesapeake Bay Program. EPA-600/8-79-029/SAV1. 219 pp.
- Orth, R. J., J. Simons, R. Allaire, V. Carter, L. Hindman, K. Moore, and N. Rybicki. 1985. Distribution of submerged aquatic vegetation in the Chesapeake Bay and tributaries—1984. Final report. Environmental Protection Agency, Cooperative Agreement X-003301-01. 155 pp.
- Orth, R. J., J. Simons, J. Capelli, V. Carter, A. Frisch, L. Hindman, S. Hodges, K. Moore, and N. Rybicki. 1987. Distribution of submerged aquatic vegetation in the Chesapeake Bay and tributaries and Chincoteague Bay—1986. Final report. U.S. Environmental Protection Agency. 180 pp.
- Orth, R. J., J. Simons, J. Capelli, V. Carter, L. Hindman, S. Hodges, K. Moore, and N. Rybicki. 1986. Distribution of submerged aquatic vegetation in the Chesapeake Bay and tributaries—1985. Final report. U.S. Environmental Protection Agency. 296 pp.
- Orth, R. J., and J. van Montfrans. 1990. Utilization of marsh and seagrass habitats by early stages of *Callinectes sapidus*: a latitudinal perspective. *Bull. Mar. Sci.* 46:126–144.
- Perry, H. M., editor. 1984. A profile of the blue crab fishery of the Gulf of Mexico. *Gulf States Mar. Fish. Comm.* 9. 80 pp.
- Reyer, A. J., D. W. Field, J. E. Cassells, C. E. Alexander, and C. L. Holland. 1988. The distribution and areal extent of coastal wetlands in estuaries of the Gulf of Mexico. National Oceanic and Atmospheric Administration, Strategic Assessment Branch, Rockville, Md. 18 pp.
- Roach, E. R., M. C. Watzin, J. D. Scurry, and J. B. Johnston. 1987. Wetland changes in Mobile Bay. Pages 92–101 in T. A. Lowery, ed. *Symposium on the natural resources of the Mobile Bay estuary*, Mobile, Alabama. Alabama Sea Grant Extension Service MASGP-87-007.

- Tiner, R. W., Jr. 1977. An inventory of South Carolina's coastal marshes. S. C. Mar. Resour. Cent. Tech. Rep. 23. 33 pp.
- Tiner, R. W., Jr. 1985a. Wetlands of New Jersey. U.S. Fish and Wildlife Service, National Wetlands Inventory, Newton Corner, Mass. 117 pp.
- Tiner, R. W., Jr. 1985b. Wetlands of the Chesapeake Bay watershed: an overview. Pages 16-24 in D. M. Burke, H. A. Groman, T. R. Henderson, J. A. Kusler, and E. J. Meyers, eds. Wetlands of the Chesapeake Bay. Environmental Law Institute. Washington, D.C. 389 pp.
- Walker, D. I. 1989. Methods for monitoring seagrass habitat. Victoria Institute of Marine Sciences, Victoria, Australia. Working Paper 18. 32 pp.

# Mapping Submerged Aquatic Vegetation in North Carolina with Conventional Aerial Photography

by

Randolph L. Ferguson and Lisa L. Wood

*National Oceanic and Atmospheric Administration  
National Marine Fisheries Service  
Southeast Fisheries Center  
Beaufort Laboratory  
Beaufort, North Carolina 28516*

**ABSTRACT.**—Mapping submerged aquatic vegetation (SAV) directly supports the National Oceanic and Atmospheric Administration's legislated responsibilities in estuarine and marine science, and it supports President Bush's no net loss of wetlands policy. Marine SAV includes some of the most productive primary producers in the marine environment. SAV functions as an underwater nursery area for juveniles or adults of many estuarine-dependent, commercially and recreationally exploited fish and shellfish. SAV is a valuable resource to monitor, conserve, and enhance, as is being done, for example, in Chesapeake Bay.

We are mapping SAV in coastal waters of North Carolina with conventional aerial photography. The immediate objective is to complete initial photographic coverage, photointerpretation, and mapping of SAV habitat in this State. We also will evaluate remote sensing of SAV by digital sensors on a variety of platforms, including satellites and aircraft. The long-term objective of this work is to monitor SAV in North Carolina and to develop a protocol to monitor SAV nationwide in coastal waters on a 2- to 4-year cycle.

Digital remote sensing of emergent and submergent wetlands may offer significant advantages for frequent monitoring of large study areas relative to aerial photography, the present standard for remote sensing and mapping of SAV. Because of its submergent existence, however, SAV is more difficult to detect and map than emergent wetland vegetation.

## Authorization

This project directly supports the National Oceanic and Atmospheric Administration's (NOAA) legislated responsibilities in estuarine and marine science, monitoring, and management contained in the Fish and Wildlife Coordination Act, the Coastal Zone Management Act, the Clean Water Act, the Marine Sanctuaries Research and Protection Act, the Magnuson Fisheries and Conservation Act, the National Environmental Policy Act, and President Bush's no net loss of wetlands policy.

## Objectives

The goals of this project are to (1) map and monitor submerged aquatic vegetation (SAV) in coastal North Carolina with conventional aerial photography, (2) evaluate digital remote sensing

of SAV from satellites and aircraft, and (3) develop a protocol for monitoring of SAV in coastal marine waters nationwide on a 2- to 4-year cycle, as part of NOAA's Coastal Ocean Program (Thomas and Ferguson 1990).

## Introduction

SAV—vegetation adapted to growing under water—includes some of the most productive primary producers in the marine environment (Ferguson et al. 1980). SAV provides habitat rich in food and cover for juveniles and adults of many estuarine-dependent, commercially and recreationally exploited fish and shellfish, but SAV also is vulnerable to adverse effects from anthropogenic activities (Zeiman 1982; Thayer et al. 1984; Zeiman and Zeiman 1989). SAV is too valuable a national resource not to monitor, conserve, and

develop on a timely basis, as is being done, for example, in Chesapeake Bay (Orth et al. 1990).

At present, we are mapping SAV in coastal North Carolina with conventional aerial photography. We will complete photographic mapping and then evaluate digital remote sensing of SAV with airborne and satellite digital sensors.

Digital remote sensing may provide significant advantages in cost and timeliness over aerial photography, the present standard for remote sensing and mapping of SAV. Costs of photographic and digital approaches are generally similar for small study areas, but costs increase rapidly for photographic approaches when subject areas exceed 50,000 ha (Klema and Hardsky 1987). SAV is difficult to detect and map relative to terrestrial or emergent habitats, however, because it occurs underwater. Although satellite imagery has been applied to detection of SAV with limited success (Ackleson and Klema 1987), SAV mapping is problematic with available satellite imagery. New airborne digital sensors, such as multispectral, solid-state video cameras (McKim et al. 1985), may ultimately provide the necessary combination of spectral and spatial resolution and flexibility of timing for image acquisition required for detection and mapping of SAV.

Conventional aerial photography is the standard approach for mapping SAV at the present time. SAV generally is mapped from photographs taken at low tide at scales of 1:24,000 or larger (Ferguson et al. 1989b; Orth et al. 1989). Emergent wetlands are routinely mapped from aerial photography taken at scales of 1:40,000 or smaller (e.g., Wilen 1990). This difference in photographic scale for the two types of wetlands is necessary because the contrast between SAV and unvegetated bottoms can be inherently low, as it is in areas where submerged sediments are dark or where water has high concentrations of dissolved organic matter or suspended particulate material. Visualization can be improved by use of large-scale photography taken when dissolved and particulate materials are at a minimum.

## Current Inventory Coverage

For a number of reasons, North Carolina is a particularly appropriate location to map SAV and test digital remote sensing of high salinity and brackish SAV, (Ferguson et al. 1989b). Of the contiguous 48 States, North Carolina, with about 81,000 ha of SAV, ranks second after Florida for

areal extent of SAV (Orth et al. 1990). In 1987, North Carolina had about four times more SAV than Chesapeake Bay (Orth et al. 1989). In coastal North Carolina, the area of SAV exceeds the area of salt marshes and is 81% of the total area (101,000 ha) of salt water plus freshwater marshes (Field et al. 1988). In North Carolina, the total estuarine area is 890,000 ha, while the estuarine shoalwater area, (that area less than 6 feet deep at mean low water [MLW]), is about 320,000 ha (U. S. Fish and Wildlife Service 1970). Bottoms less than 6 feet deep at MLW are potentially habitable by SAV in coastal North Carolina (Ferguson et al. 1989b). Therefore, about 9% of the total estuarine area and 25% of the potentially habitable estuarine shoal area in the sounds of North Carolina currently support SAV.

The Beaufort Laboratory of the National Marine Fisheries Service (NMFS) has aerial photography of most known SAV in coastal North Carolina (Figure) at scales of 1:12,000 to 1:50,000. The photography covers the sounds from Bogue Inlet to Drum Inlet in 1985 at a scale of 1:12,000 or 1:20,000, and the sounds from Cape Lookout to Oregon Inlet, northern Core Sound, and southern and eastern Pamlico Sound in 1988 at scales of 1:24,000 and 1:50,000. The 1:50,000 photography was taken to provide horizontal control for the soundward leg of two parallel flight lines of 1:24,000-scale photography required to span the entire width of the extensive shoal area in eastern Pamlico Sound.

Photointerpretation and photography is ongoing (Figure), but the extent of photography interpreted and mapped has been limited. Only about 5% of total SAV habitat—seagrass habitat in southern Core Sound between Cape Lookout and Drum Inlet—has been delineated in a published chart (Ferguson et al. 1989b). The 1988 1:50,000-scale photography (but not the 1:24,000) from Ocracoke Inlet to Oregon Inlet has been interpreted, and preliminary seagrass maps have been digitized for that area. A preliminary map of seagrasses in northern Core Sound also has been digitized based on interpretation of the 1988, 1:24,000-scale photography, and a chart of SAV that includes this area will be published in 1991. Seagrass occurs in western Pamlico Sound, in southern Roanoke Sound, and west of Bogue Inlet to the border with South Carolina, but these areas, as well as SAV in brackish-water areas of northern Roanoke, Albemarle, and Currituck sounds have not yet been suitably photographed.

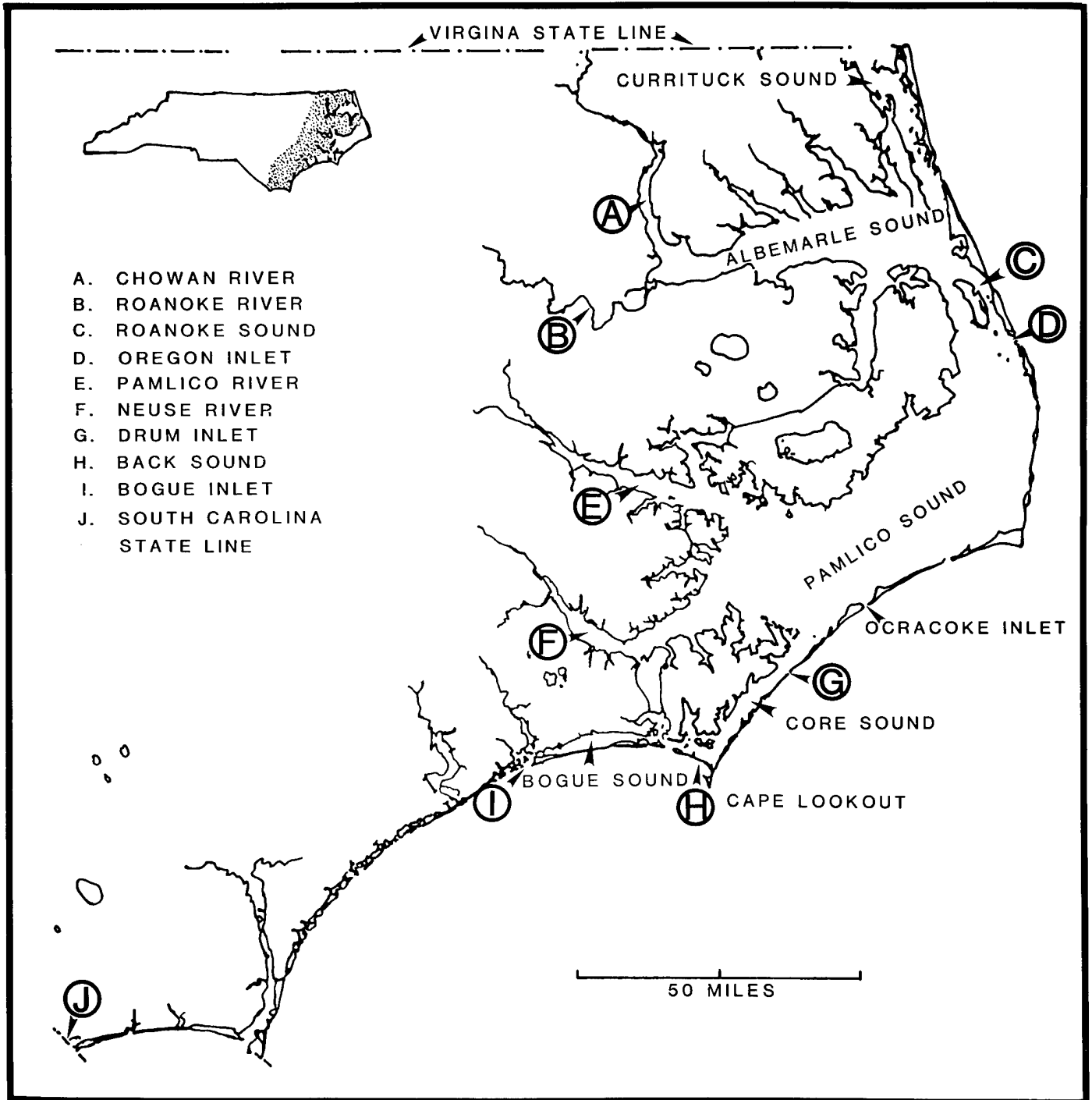

Figure. Coastal North Carolina.

Albemarle and Currituck sounds will be photographed in 1990 with funding from the Albemarle-Pamlico Estuarine Study.

Surface-level sampling has progressed beyond the area presently photographed and includes both high-salinity and brackish-water areas (Ferguson et al. 1989b). High- and intermediate-salinity waters in North Carolina are populated by the temperate species, eelgrass (*Zostera marina*); the tropical species, shoalgrass (*Halodule wrightii*); and the panlatitudinal species, widgeon grass (*Ruppia maritima*). Unlike eelgrass and shoalgrass, widgeon grass is euryhaline and occurs in both high-salinity waters and brackish waters. North Carolina is the southern limit for eelgrass and the northern limit for shoalgrass on the east coast (Thayer et al. 1984). The northern limit of shoalgrass has been extended to near Oregon Inlet, North Carolina (Ferguson et al. 1989b).

SAV includes seagrasses that require moderate- to high-salinity seawater and it includes freshwater species that tolerate low-salinity brackish water. An exception is widgeongrass, which thrives in fresh water and in seawater. The SAV species of eelgrass, shoalgrass, and widgeongrass occur to a limited extent in southern Roanoke Sound, but are abundant to the south in Pamlico, Core, Back, and Bogue sounds (Figure). These species also occur west of Bogue Sound and to the border with South Carolina. In Pamlico, Core, Back, and Bogue sounds, SAV habitats tend to be large and luxuriant on the extensive shoals along the inside of the Outer Banks where salinity tends to be highest and bottoms are sandy. Along the Outer Banks, muddy shoals also support luxuriant seagrass meadows, but these areas are restricted to small protected bays associated with emergent marshes. In contrast, the relatively soft bottom of the mainland shore in Core Sound is characterized by thin shoreline beds. Although SAV occurs in western Pamlico Sound, eelgrass and shoalgrass are displaced in the low-salinity areas of the estuaries of lower Neuse and Pamlico rivers by species tolerant to brackish waters. These two species also have not been reported to occur in Albemarle or Currituck sounds.

SAV does occur in brackish waters of the estuaries of the Neuse and Pamlico rivers and in the Albemarle, Currituck, and northern Roanoke sounds (Beal 1977; Ferguson et al. 1989b), where salinities remain low and waters tend to be turbid. Species common in brackish water in coastal North Carolina include Eurasian water milfoil (*Myrio-*

*phyllum spicatum*), bushy pondweed (*Najas quadalupensis*), sago pondweed (*Potamogeton pectinatus*), redhead grass (*P. perfoliatus*), widgeongrass (*Ruppia maritima*), wild celery (*Vallisneria americana*), and horned pondweed (*Zannichellia palustris*).

## Project Period and Scope

This project began in 1985 in North Carolina under base (NMFS) funding from the Beaufort Laboratory, Southeast Fisheries Center. Subsequently, project activities have been supported with additional funding from NOAA's Coastal Ocean Program and the U.S. Environmental Protection Agency's (EPA) National Estuarine Program for Albemarle and Pamlico sounds. The first aerial photography (both color and infrared) was done using base funds for Bogue, Back, and southern Core sounds in 1985. Additional support was obtained in 1987-1988 and in 1990-1991 from EPA's Albemarle-Pamlico Program. Under this funding, a visual aerial survey (December 1987) of Core Sound and eastern Albemarle and Pamlico sounds, and photography (April 1988) of Core Sound and eastern Pamlico Sound (both color and infrared at scales of 1:24,000 and 1:50,000), were completed. SAV samples from Core, eastern Pamlico, Roanoke, and eastern Albemarle sounds (March 1988) and Currituck Sound (October 1987) also were collected to provide ground-level verification for interpretation of current and anticipated photography, and to provide regional data on species composition of SAV.

Project activities are ongoing. Funding from NOAA's Coastal Ocean Program will allow (1) completion of interpretation of photography and analysis of SAV and sediment samples in hand, (2) construction and publication of SAV charts, (3) testing of remote sensing of SAV by digital sensors, and (4) development of a protocol for nationwide monitoring of SAV. Cooperative funding from NOAA and EPA will provide for complete photographic coverage and initial mapping of SAV in coastal North Carolina. Subsequently, funding will be sought to implement a SAV habitat monitoring program. We anticipate that the initial mapping of North Carolina will be completed in 1993 and that the monitoring will continue indefinitely. Testing of digital sensors has not begun, but will be proposed as technological advances and funding permit (Thomas and Ferguson 1990).

## Product Description

We have two types of products. Published charts are on 3- by 4-foot chart paper at a scale of 1:36,000. The subject area's of the two charts published to date are southern Core Sound between Cape Lookout and Drum Inlet (Ferguson et al. 1989a), and northern Core Sound and southeastern Pamlico Sound between Drum Inlet and Ocracoke Inlet (Ferguson, et al. 1991). The next chart to be published (with a similar size and scale) will document change in SAV habitat (1985 to 1988) in southern Core Sound. The second type of product is a digital data base. The SAV habitat data are stored in a geographic information system (GIS).

## Inventory Methods

Inventory methods include acquisition of photography and surface-level information and photointerpretation. Cartographic products can be no better than the quality of the source data, which are the aerial photography and surface-level samples. Aerial photography for the project has been conducted by NOAA, National Ocean Survey, and Coastal and Geodetic Services (CGS) in Rockville, Maryland. We select seasonally optimal times based on biological considerations and potential for clear-air days. These times are April and May or late August through early October for moderate- to high-salinity areas in coastal North Carolina. Different species of SAV in moderate- to high-salinity waters in North Carolina achieve maximum biomass at different times; eelgrass in late spring, and shoalgrass and widgeongrass in late summer to early fall (Ferguson et al. 1989a,b). Brackish-water SAV is best photographed during maximum biomass, which occurs between August and October for most species in North Carolina. Within these seasonal windows, the decision to fly a particular photographic mission is dependent on time of day (sun angle less than 25° to minimize glint from reflected sunlight), tidal stage (low for minimum amount of water to penetrate), and other local conditions (absence of cloud cover, minimal haze, low water turbidity, and absence of surface waves). During photography, location along flight line, yaw, pitch, and altitude are controlled within CGS guidelines by the pilot and navigator. The photographer determines exposure, focus, and overlap of adjacent exposures. Sequential photographs along a flight

line have 60% endlap, and photographs along parallel flight lines have 20% sidelap. Development and copying of film are done commercially by a contractor for CGS and follow CGS guidelines and quality-control procedures.

Surface-level information is acquired in two phases. The first phase of sampling collects regional information about SAV and environmental conditions, especially turbidity, in the study area. Stations for sampling of SAV are selected by a dot-matrix approach. A matrix of rectangularly arranged dots of appropriate dimensions and spatial density (e.g., 1.3-scaled nautical miles from center to center) is placed over a NOAA nautical chart. The latitude and longitude of dots occurring at water depths of 0 to 10 feet are determined. These locations are then visited with the aid of LORAN C, and they are examined for the presence of SAV to a radius of about 0.2 nautical miles. Any SAV present is identified to species or is sampled along with surface sediment and returned to the laboratory for analysis. Salinity and Secchi disc depth are recorded. Activities affecting water quality (e.g., dredging, commercial fishing activity, or local drainage of turbid water) are noted along with general environmental observations at the site. This sampling phase is done just before and during the photographic mission. At this time, the surface party is in periodic (at least daily) contact with the flight crew by telephone or radio to discuss the mission decisions for a given day.

SAV habitat noted in the first phase of surface-level sampling is key to the recognition of the variety of SAV habitat areas visible in the photography. Interpreting photos of SAV habitat is based on the photointerpreter's experience and often involves subjective judgment. Visualization is best achieved stereoscopically at low magnification (e.g.,  $\times 8$ ), viewing pairs of the 9- by 9-inch color transparencies illuminated with high-, uniform-, and variable-intensity light. Appearance of SAV habitat can vary considerably and may not be consistent from place to place. Experience is required to identify and delineate SAV habitat with accuracy and reproducibility. That experience is increased by feedback from the second phase of surface-level sampling.

The second phase of surface-level sampling occurs subsequent to the acquisition and initial examination of the photography, and it is an essential training activity for photointerpreters. Specific areas of SAV habitat not sampled during phase one—in particular, unusual, potential, or ques-

tionable SAV habitat observed in the photography—are located and visited.

SAV habitat is circumscribed by tracing a pencil line around continuous meadows of SAV or clusters of “patches” of SAV onto a stable base overlay of the photograph. The growth form of SAV beds is a combination of historical and present physical and biological interactions (Fonseca et al. 1983; Fonseca and Kenworthy 1987). Thus, areas with clusters of SAV patches, as well as areas with apparently continuous cover of SAV, constitute SAV habitat. We have made no attempt yet to categorize polygons of SAV habitat according to the two gradients of patchy to continuous and thin to dense. Distinctions tend to be arbitrary and problematic. The appearance of SAV bed form can change, for example, as a function of scale and overall quality of the photography. Beds of SAV, moreover, often intergrade from one growth form to another. The causative factors of the different bed forms and their significance to secondary productivity and habitat management issues, in any case, remain the subject of further research.

In our experience, estimates of SAV habitat tend to be conservative. For example, thinly grassed areas (e.g., shoreline beds with a continuous cover of small plants on dark-appearing bottoms, or widely dispersed patches of SAV) can be virtually undetectable in the photography, depending on water clarity, substrate darkness, and photography scale. SAV habitat discovered by surface-level sampling is added to the photographic tracings after in situ measurement of the habitat and reexamination of the photography. Under ideal conditions, individual SAV patches as small as 1 m in diameter are detectable (with magnification) in photography at a scale of 1:24,000, but in practice, minimum habitat sizes recorded are  $\leq 0.3$  ha.

The project maintains all commissioned photography, photographic-scale stable base tracings of SAV habitat, stable base reference maps, and stable base SAV overlays. We are also seeking historical photography and examining it for reference and retroactive change analysis of SAV distribution and extent. Unfortunately, historical photography often is of limited value for estimating total SAV habitat because of the absence of surface-level verification and because of inappropriate scale, season, tidal stage, water turbidity, sun glint, or areal coverage.

## Cartographic Procedures

Cartographic procedures include georeferencing, scaling, compiling, production of chart products, and digitization of SAV habitat data. The base maps are 1:24,000-scale, 7.5-min United States Geological Survey (USGS) topographic maps or 1:20,000-scale CGS shoreline manuscripts. Four cultural (e.g., road intersections and buildings) and, if necessary, natural (e.g., shorelines) features visible in the photograph and also present in the base map are traced, along with the polygons of SAV habitat, to provide horizontal control for the photography. The SAV polygons are compiled on referenced stable base overlay of the base map by tracing, if scales are consistent, or with a zoom transfer scope that also allows for scaling and (if necessary) correction for distortion. Subsequently, the SAV habitat tracings are inked using a 0.3-mm permanent ink pen.

The inked SAV overlays and their base maps are the source materials for charts produced by standard photographic and printing techniques and for digitizing and plotting computer-generated maps. Printed chart products of SAV habitat are produced by CGS. For the chart that was published in 1989 (Ferguson et al. 1989a), SAV habitat information was superimposed on a base map compiled from edited stable bases of USGS 7.5-min quadrangles for shoreline and land information, and NOAA nautical charts for navigational aids (channel markers) and bathymetric data. The chart published in 1991, for the area between Drum Inlet and Ocracoke Inlet, is based on CGS shoreline manuscripts generated from photography collected at the same time as that for SAV (1988). This is being done because changes in shoreline between the most recently published USGS maps and our 1988 photography were substantial. The SAV overlays are digitized on a cooperative basis, and maps are generated as computer plots by the State of North Carolina, Department of Environment, Health and Natural Resources, Center for Geographic Information and Analysis (CGIA), in Raleigh. For map products or information about obtaining map products, see Appendix A.

## Estimated Funding

Estimated funding requirements for aerial photographic mapping of SAV in marine and brackish waters of coastal North Carolina are \$190,000 per year for 3 years. This amount includes photogra-



phy, photointerpretation, surface-level sampling, scaling and compiling of SAV on 1:24,000-scale USGS maps, digitizing into a GIS system, and construction and publication of SAV charts. It does not include funding required to construct current CGS shoreline manuscripts. Requirements for mapping SAV in other States would be similar, dependent on the extent of estuarine shoal areas, growth characteristics and extent of SAV, and water- and bottom-quality considerations. Additional funds, dependent on sensor and platform, are required to conduct evaluations of digital remote sensors.

## Anticipated Future Activities

Anticipated future activities include (1) completion of initial aerial photographic mapping of SAV in coastal North Carolina, (2) initiation of monitoring of SAV in coastal North Carolina on a cycle of 2 to 4 years, (3) evaluation of digital sensors (e.g., Landsat Thematic Mapper, SPOT, and airborne multispectral solid-state video camera) for detection and mapping of SAV habitat, (4) development of a protocol including photographic and digital imagery for mapping SAV, and (5) coordination with or initiation of mapping of SAV in the coastal areas of other States.

## User Perspective

State and Federal environmental managers and researchers and private citizens have been particularly interested in information related to location and extent of SAV. A blue-ribbon panel on environmental indicators recently reported to the governor of North Carolina a high-priority need for assessment of SAV as an indicator of coastal water quality and of the well-being of the State's living marine resources. Throughout this project, the following information requests concerning SAV have been received:

- habitat measurement methodology,
- importance to fisheries,
- importance to waterfowl,
- distribution of endemic eelgrass wasting disease,
- regulation of inshore fishing activities,
- distribution as an oil-sensitive habitat,
- site-specific occurrence and species composition in areas proposed for dredge and fill operations or water-related construction,
- index for monitoring water quality and health of living marine resources,
- justification for classification of areas as outstanding resource waters, and
- public interest reports in newspapers and on television.

## References

- Ackleson, S. G., and V. Klemas. 1987. Remote sensing of submerged aquatic vegetation in lower Chesapeake Bay: a comparison of Landsat MSS to TM imagery. *Remote Sens. Environ.* 22:235-248.
- Beal, E. O. 1977. A manual of marsh and aquatic vascular plants of North Carolina with habitat data. North Carolina Agricultural Experiment Station, N.C. State Univ. Raleigh. Tech. Bull. 247. 298 pp.
- Ferguson, R. L., J. A. Rivera, and L. L. Wood. 1989a. Seagrasses in southern Core Sound, North Carolina. NOAA-Fisheries Submerged Aquatic Vegetation study, southern Core Sound, North Carolina. National Oceanic and Atmospheric Administration-Fisheries, Beaufort Laboratory, Beaufort, N.C. 3- x 4-foot chart, with text and illustrations.
- Ferguson, R. L., J. A. Rivera, and L. L. Wood. 1989b. Submerged aquatic vegetation in the Albemarle-Pamlico estuarine system. North Carolina Department of Natural Resources and Community Development, Raleigh, N.C., and U.S. Environmental Protection Agency, National Estuary Program. Albemarle-Pamlico Estuarine Study, Project 88-10. 68 pp.
- Ferguson, R. L., G. W. Thayer, and T. R. Rice. 1980. Marine primary producers. Pages 9-69 in F. J. Vernberg and W. Vernberg, eds. *Functional adaptations of marine organisms*. Academic Press, New York.
- Ferguson, R. L., L. L. Wood, and B. T. Pawlak. 1991. SAV habitat from Drum Inlet to Ocracoke Inlet, North Carolina. NOAA-Coastal Ocean Program Submerged Aquatic Vegetation Study. National Oceanic and Atmospheric Administration/National Marine Fisheries Service, Beaufort Laboratory, Beaufort, N.C. [Three- by four-foot chart with text and illustrations]
- Field D. W., C. E. Alexander, and M. Broutman. 1988. Toward developing an inventory of U.S. coastal wetlands. *Mar. Fish. Rev.* 50(1):40-46.
- Fonseca, M. S., and W. J. Kenworthy. 1987. Effects of current on photosynthesis and distribution of seagrasses. *Aquat. Bot.* 27:59-78.
- Fonseca, M. S., J. C. Zieman, G. W. Thayer, and J. S. Fisher. 1983. The role of current velocity in structuring eelgrass (*Zostera marina* L.) meadows. *Estuarine Coastal Shelf Sci.* 17:367-380.
- Klemas, V., and M. A. Hardisky. 1987. Remote sensing of estuaries: an overview. Pages 91-120 in V. Klemas, J. P. Thomas, and J. B. Zaitzeff, eds. *Remote sensing of estuaries, proceedings of a workshop*. U.S. Department of Commerce, National Oceanic and Atmospheric Administration, Estuarine Programs Office and National Environmental Satellite Data Service, Washington, D.C.

- McKim, H. L., V. Klemas, L. W. Gatto, and C. J. Merry. 1985. Potential of remote sensing in the Corps of Engineers dredging program, U.S. Army Water Resources Support Center, U.S. Army Corps of Engineers Cold Regions Research and Engineering Laboratory, Hanover, N.H. Spec. Rep. 85-20. 42 pp.
- Orth, R. J., A. A. Frisch, J. F. Nowak, and K. A. Moore. 1989. Distribution of submerged aquatic vegetation in the Chesapeake Bay and tributaries and Chincoteague Bay 1987. Chesapeake Bay Program, U.S. Environmental Protection Agency, Annapolis, Md. 247 pp.
- Orth, R. J., K. A. Moore, and J. C. Nowak. 1990. Monitoring seagrass distribution and abundance patterns: a case study from the Chesapeake Bay. Pages 112-124 in S. J. Kiraly, F. A. Cross, and J. D. Buffington, tech. coords. Federal coastal wetland mapping programs. U.S. Fish Wildl. Serv., Biol. Rep. 90(18).
- Thayer, G. W., W. J. Kenworthy, and M. S. Fonseca. 1984. The ecology of eelgrass meadows of the Atlantic coast: a community profile. U.S. Fish Wildl. Serv., FWS/OBS-84/02. 147 pp.
- Thomas, J., and R. L. Ferguson. 1990. National Oceanic and Atmospheric Administration's habitat mapping under the Coastal Ocean Program. Pages 27-37 in S. J. Kiraly, F. A. Cross, and J. D. Buffington, eds. Federal coastal wetland mapping programs. U.S. Fish Wildl. Serv., Biol. Rep. 90(18).
- U.S. Fish and Wildlife Service. 1970. Technological impacts on estuary resource use. Pages 1-122 in National estuary study. Vol. 5. U.S. Government Printing Office, Washington, D.C.
- Wilens, W. 1990. The U.S. Fish and Wildlife Service's National Wetlands Inventory. Pages 9-20 in S. J. Kiraly, F. A. Cross, and J. D. Buffington, eds. Federal coastal wetland mapping programs. U.S. Fish Wildl. Serv., Biol. Rep. 90(18).
- Zeiman, J. C. 1982. The ecology of the seagrasses of south Florida: a community profile. U.S. Fish Wildl. Serv., FWS/OBS-82/25. 185 pp.
- Zeiman, J. C., and R. T. Zeiman. 1989. The ecology of the seagrass meadows of the west coast of Florida: a community profile. U.S. Fish Wildl. Serv., Biol. Rep. 85(7.25). 155 pp.

## Appendix. Availability of Map Products and Contacts for More Information

---

For a free copy of published charts or more information on SAV mapping, write to:

Randolph L. Ferguson  
NOAA, National Marine Fisheries Service  
Beaufort Laboratory, Southeast Fisheries Center  
Beaufort, North Carolina 28516

For a customized computer plot of SAV (not free) or more information on digitization of SAV data and the North Carolina GIS data base, write to:

Karen Siderelis, Director  
Center for Geographic Information and Analysis  
North Carolina Department of Environment, Health and Natural Resources  
512 North Salisbury Street, Room 1193  
P. O. Box 27687  
Raleigh, North Carolina 27611

For more information on aerial photographic and cartographic procedures, write to:

Rear Admiral J. Austin Yeager N/CG  
Director, Charting and Geodetic Services  
NOAA, National Ocean Service  
Room 1006, Rockwall Building  
6001 Executive Boulevard  
Rockville, Maryland 20852

# Project Plan for Mapping and Geographic Information System Implementation of Land Use and Land Cover Categories for the Albemarle-Pamlico Estuarine Study

by

H. M. Cheshire and Siamak Khorram

*Computer Graphics Center  
North Carolina State University  
Raleigh, North Carolina 27695-7106*

**ABSTRACT.**—The Albemarle-Pamlico (A/P) system in North Carolina is one of 12 estuaries in the U.S. Environmental Protection Agency's National Estuary Program. The lack of a current land use inventory for the Albemarle-Pamlico estuarine drainage area has been identified as a critical gap in the A/P Study resource data base. At an A/P Study workshop late in 1987, Landsat Thematic Mapper (TM) digital data were recommended as the most cost-effective and practical source for developing an inventory for the 12 million acres of A/P drainage basin. The Computer Graphics Center (North Carolina State University) and the Center for Geographic Information and Analysis (formerly Land Resources Information Service; North Carolina Department of Environment, Health and Natural Resources) are cooperating in the development, storage, and dissemination of the inventory. The study area includes a portion of Virginia and nearly one-third of North Carolina including almost all of the Tidewater region. The project will result in: 1) a current digital land use and land cover inventory based on Landsat TM data classified, verified, and registered to the A/P Study geographic information system data base; 2) digital files in a standard data exchange format available to investigators and resource managers; 3) a capability within the A/P Data Management Center to maintain, analyze, and make future updates to the inventory; and 4) land use and land cover maps summarized by geopolitical boundaries.

## Objectives and Background

The Albemarle-Pamlico Estuarine Study (A/P Study) is a joint project of the U.S. Environmental Protection Agency (EPA) and the State of North Carolina. The estuary is 1 of 12 in the Federal National Estuary Program. The ultimate goal of the A/P Study is to aid in effective management of the important estuarine resources in northeastern North Carolina through scientific research and public awareness. The North Carolina A/P Study Program Office determined that lack of a land use inventory for the Albemarle-Pamlico estuary was a critical gap in the A/P resource data base. As a result of an A/P Study workshop in late 1987, Landsat Thematic Mapper (TM) data were identified as the most practical and cost-effective data source for developing a land use inventory for the more than 12 million acres of drainage basin. The study area includes all of the tributary basins of

Albemarle and Pamlico sounds, encompassing about 3,000 square miles of protected inshore waters and 20,000 square miles of land. It includes over two-thirds of North Carolina's coastal wetlands and extends west into the Piedmont region.

In 1989, the Computer Graphics Center (CGC) at North Carolina State University and the Center for Geographic Information and Analysis (CGIA) were funded to conduct such an inventory. The CGC is a university-wide research unit that conducts research and training in the areas of remote sensing, image processing, geographic information system (GIS) design and applications, and integrated relational data-base design and management systems. The CGIA operates a GIS and serves as the official repository of digital geographic data for the State of North Carolina. The CGIA is a receipt-funded agency in the Division of Information Services, North Carolina Department of Environment, Health, and Natural Resources.

The goal of this mapping project is to provide baseline data on the Albemarle–Pamlico drainage basin resources in a form usable by scientists and decision makers to aid in research and management activities. The objectives of the project are to (1) develop a current digital land use and land cover inventory of the entire Albemarle–Pamlico drainage area, (2) integrate these data into the A/P Study data base at CGIA, and (3) develop mechanisms for maintaining and updating the land use and land cover data. Up-to-date, accurate land use and land cover data are not currently available for North Carolina, but would serve a critical need in the user community.

## Methodology

### *General Approach*

Landsat TM digital data will be used to map land use and land cover over the entire Albemarle–Pamlico Study area. Data will be partly classified based on, U.S. Geological Survey (USGS) Standard Level II categories with a minimum mapping unit of 5 to 10 acres. Land use and land cover information will then be integrated with the A/P Study data base being maintained at CGIA, and procedures for updating the information will be outlined.

### *Remote Sensing Data Acquisition*

Five Landsat TM scenes cover all but a very small portion of the Albemarle–Pamlico drainage basin. The study area encompasses nearly one-third the land area of North Carolina and a portion of southeastern Virginia. Cloud cover made the most recent (1989) TM scenes unsuitable for use over much of the area, but five scenes from winter of 1987 and 1988 (November, December, and January) have been acquired from Earth Observation Satellite Company. Aerial photography required for location of training sites or verification of classification accuracy will be obtained from existing sources.

### *Data Analysis*

Remotely sensed data will initially be digitally analyzed by North Carolina State University personnel at CGC facilities. The major-image processing software package at CGC is the Land Analysis System running under the Transportable Applications Executive, both of which were developed by

National Aeronautics and Space Administration–Goddard Space Flight Center. A number of specific applications have also been developed by CGC staff and implemented under the Land Analysis System. Before analyses, TM data will be converted to a Lambert Conformal projection to improve compatibility with the CGIA A/P data base.

The drainage area encompasses several physiographic provinces including Tidewater, Middle and Upper Coastal Plains, and Piedmont. Windows roughly corresponding to the physiographic provinces will be created from each TM scene so that an area under consideration at any one time will be fairly uniform with respect to topography, soils, moisture, and other physical characteristics. A guided clustering algorithm will be used for an initial separation of each area into broad, Level I, categories. Each broad category will then be broken down into more detailed categories. Training sites in the TM scenes will be used for testing which combination of bands is best suited for discriminating more detail within each broad category. Spectral signatures of the more detailed cover types will also be determined by interactive guided clustering of digital data for training sites. The clustering algorithm developed at CGC provides the analyst with an interactive display of the spatial distributions of clusters at each iteration and with final cluster statistics. The clusters will be compared with maps or photographs of each site to determine if the clustering process has adequately characterized a training site. We expect that several clusters or spectral signatures will be found representing each cover type. Cluster statistics will be compiled, nonunique clusters will be deleted or merged, and confusion areas will be identified.

At this point, the list of land use and land cover categories may be revised to show categories not previously included but which are distinct on the imagery, or to merge categories that cannot be adequately separated. Cluster statistics will then be used to categorize an entire window by using a K-means minimum distance classifier. Data from the various windows (and categorical levels) will be recombined and classification accuracies will be evaluated before transfer to CGIA.

### *Registration and Vertical Integration of Data*

CGIA has acquired the Earth Resources Data Analysis Systems (ERDAS) software, which is compatible with the ARC/INFO GIS. Classified

image data from the Land Analysis System at the Computer Graphics Center is being converted to ERDAS format and transferred to CGIA as classifications are completed. Personnel from CGIA will complete the transfer from ERDAS to the ARC/INFO Albemarle-Pamlico Study data base. This transfer initially consists of vectorizing the land use data and entering them into ARC/INFO. Land use data will have to be registered to the existing A/P data base to ensure geometric accuracy and data continuity.

## Final Results

The inventory will provide complete coverage for all but about 3% of the A/P drainage area. The data will be georeferenced to the North Carolina State Plane Coordinate System and will be integrated with the existing A/P data base.

Classified color-coded image data will be reproduced in photographic format at an approximate scale of 1:250,000. Results of the classification may also be plotted in map format at variable scales. CGIA plans to produce a series of acre summary reports of land use by county and subbasin. CGIA will also produce digital files of land use data in a standard data exchange format that can be distributed on a cost-recovery basis for use in GIS's installed in county, local, and regional agencies, and to other A/P cooperating agencies, such as EPA, USGS, and the U.S. Army Corps of Engineers.

In addition, procedures for maintaining and updating the information will be in place at the completion of this project. CGC and CGIA will produce a report that describes the techniques used to develop the land use and land cover inventory, defines the classification scheme, documents the limitations of the satellite data, and describes the data available at CGIA for the project area.

## Project Status

In summer 1989, an advisory committee met to review the project and to discuss a proposed classification scheme. The committee consisted of representatives from Federal, State, and local agencies, including the U.S. Fish and Wildlife Service, EPA, the North Carolina Department of Agriculture, North Carolina Divisions of Coastal Management and Environmental Management, University of North Carolina, North Carolina State University, CGIA, and city, county, and regional planning agencies. The committee approved the 5-

to 10-acre mapping unit and recommended a classification scheme compatible with the USGS standard hierarchical land use and land cover classification scheme. This classification scheme would provide a framework for the identification of broad categories, but is flexible enough to permit aggregation or greater separation at lower levels. For example, while the project is committed only to differentiating between forested and nonforested wetlands (Level II), it is fully expected that greater separation will be possible. For instance, the user community would benefit from information on the relative distributions of salt marshes versus freshwater coastal marshes. Particular interest has been expressed in determining if stands of Atlantic white-cedar (*Chamaecyparis thyoides*) can be identified from the digital data. These possibilities will be investigated as the project progresses.

In October 1989, a half-day introductory training session at the Computer Graphics Center introduced CGIA personnel to the basics of remote-sensing technology. Topics included terminology, characteristics of Landsat TM data, and a discussion of the approach to be used in completing the project. Two people from CGIA have been designated to work on the A/P Study and are being trained in digital image processing at the Computer Graphics Center. CGIA has just received ERDAS, and completed installation in January 1990. The total funding for this portion of the project, including GIS implementation, is \$139,622.

## Time Schedule

Image classification was completed on the first image by the end of March (1990). This also marked completion of formal training of key CGIA personnel. Work on conversion of the Land Analysis System data to ERDAS format began as soon as CGIA received the first scene. By early spring 1990, procedures for classifying and transferring the data will have been tested and verified. The target date for completing the raster-to-vector conversion and integration with ARC/INFO is 30 September 1990. Final results of the image classification are expected to be available through CGIA by October 1990 and are currently available for selected areas.

## Relevance of Project Results

The need for land use and land cover data has been clearly expressed by managers and research-

ers concerned with the Albemarle and Pamlico sounds. No accurate assessments of the contributions of nonpoint sources to instream water-quality problems can occur without up-to-date information on land use. Assessing the effects of nonpoint source activities on eutrophication will be critical for developing effective management strategies. Resource analysts may also use acreage estimates of land uses to sensitive areas to estimate loading values for sediments, nutrients, or toxic substances for use in water-quality or groundwater models. Researchers will also use the information for wildlife habitat analyses or multistage sampling. Resource managers require the information for evaluating proposed development, determining the proximity of a particular land use to water intake locations, point source discharges, or other critical point locations, or for generating acre summary reports for land use categories.

An advisory committee has been established by the Computer Graphics Center and CGIA to oversee the project. This committee consists of resource managers from Federal and State agen-

cies, representatives of county and local governments in the A/P Study area, and university personnel. The committee represents the data needs of the user community. The committee's objectives are to (1) assist in refining the land use classification scheme, (2) identify critical areas for which more detailed resource data are needed, (3) recommend output products, and (4) plan for future data needs beyond the time frame of this project.

The State of North Carolina is considering the use of Landsat TM or other remotely sensed data for developing land use and land cover information for the entire State on a regular 2- to 5-year basis. The advisory committee will help evaluate the results of this A/P Study to determine if the approach produces products that will meet the needs of the user community.

## Acknowledgments

We wish to acknowledge the cooperation and participation of the Center for Geographic Information and Analysis.

## Loss of Coastal Wetlands in Louisiana: Cooperative Research to Assess the Critical Processes

by

S. Jeffress Williams

*U.S. Geological Survey  
914 National Center  
Reston, Virginia 22092*

and

Asbury H. Sallenger, Jr.

*U.S. Geological Survey  
600 Fourth Street, South  
St. Petersburg, Florida 33701*

**ABSTRACT.**—Erosion of the Nation's shorelines and loss and deterioration of our coastal wetlands are widespread and serious problems that affect all regions of the United States. As a result of natural and human-induced factors, the coastal plain of Louisiana, which contains 40% of the tidal wetlands in the conterminous 48 States, is undergoing the greatest amount of coastal erosion and wetlands loss of any State in the Nation. The barrier islands that provide a natural buffer for Louisiana's deltaic plain environments are experiencing erosion rates of 20 m/year, while wetlands losses are about 100 km<sup>2</sup>/year. In response to these problems and the lack of scientific understanding of the processes causing erosion and land loss, the U.S. Geological Survey has, since 1986, conducted field investigations in Louisiana, working closely with the U.S. Fish and Wildlife Service and other Federal and State agencies. Research elements included in the studies of Louisiana's coastal barriers and wetlands are (1) the shallow geologic framework, (2) documentation by maps and aerial photographs of the physical changes that have occurred during the past 135 years, (3) measurements of several critical processes in the coastal zone and in a typical sediment-starved or sediment-rich basin, and (4) transfer of the results and findings to coastal resource managers. Studies of a similar nature are also under way in Lake Michigan and along the Alabama-Mississippi coast.

More than one-half of the U.S. population lives within a 1-hour drive of the Nation's marine or Great Lakes coasts, and the density of population and development in the coastal zone is predicted to increase into the 21st century. At present, developed coastal areas face potential loss of life and billions of dollars in property damage because of long-term coastal erosion and storm effects. In addition, valuable coastal wetlands and estuarine habitats are being rapidly altered as a result of natural and human-induced factors. All 30 States

bordering a coast are experiencing erosion and wetland deterioration, and 26 of these States suffer from an overall net erosion of their shorelines. The National Academy of Sciences forecasts an increase in sea level rise; this would accelerate coastal erosion and wetland degradation.

The physical processes causing wetlands loss and barrier island erosion are complex and varied, and many are not well understood. In addition, the technical and academic community debates about which of the many contributing processes, both



natural and human-induced, are most significant. Controversy also surrounds some of the measures that are being proposed to mitigate erosion and reduce wetlands loss. Much of the debate is focused on the reliability of predicted results of a given management, restoration, or erosion mitigation technique. With better understanding of the physical processes of wetlands loss, such predictions will become more accurate, and a clearer consensus should appear on how to reduce erosion and land loss.

### Role of the U.S. Geological Survey in Coastal Erosion and Wetlands Loss Research

As the primary Federal agency for conducting research and information gathering on all earth science topics, the U.S. Geological Survey (USGS) is engaged in studies focused on improving scientific understanding of the physical processes affecting coastal environments. USGS's Coastal Geology Program consists of four major studies: (1) Louisiana Barrier Island Erosion Study, (2) Louisiana Wetlands Loss Study, (3) Southern Lake Michigan Coastal Erosion Study, and (4) Alabama/Mississippi Coastal Erosion and Pollution Study. Each study is being done in close cooperation with other

Federal agencies and State geological surveys as well as academic researchers.

### Louisiana Barrier Island Erosion Study

As shown in Fig. 1, much of the territory bordering the Gulf of Mexico is undergoing shoreline erosion. Louisiana, however, has the greatest rate of erosion compared with other Gulf region States, and also with other coastal States. Much of this erosion occurs along the barrier islands, which act as buffers, protecting the wetlands and estuaries landward from the effects of storms, ocean waves, and currents.

In 1986, the USGS and the Louisiana Geological Survey (LGS) began a 5-year study that focuses on the processes causing barrier island erosion. The study areas (Fig. 2) extend from the Isles Dernieres to Sandy Point and to the Chandeleur Islands east of the Mississippi River Delta. Because long-term erosion of Louisiana's barrier islands is due to both sea level rise, relative to the land, and diminishing sand supply, the primary objectives of this study are to quantify processes related to sea level rise and sand supply, and to present the results in a form that can be applied to practical problems such as predicting future

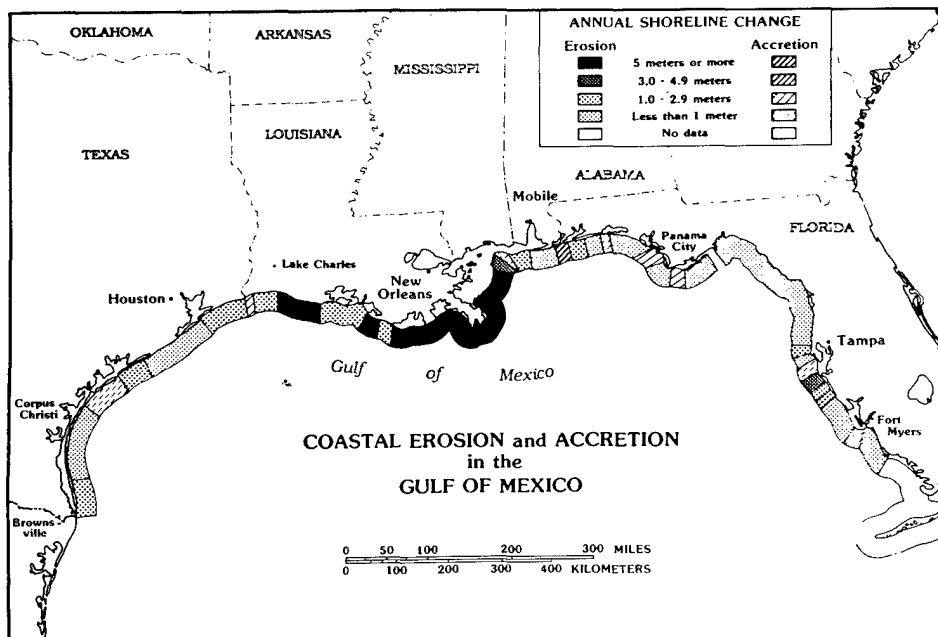

Fig. 1. Map of shoreline erosion and accretion around the Gulf of Mexico.

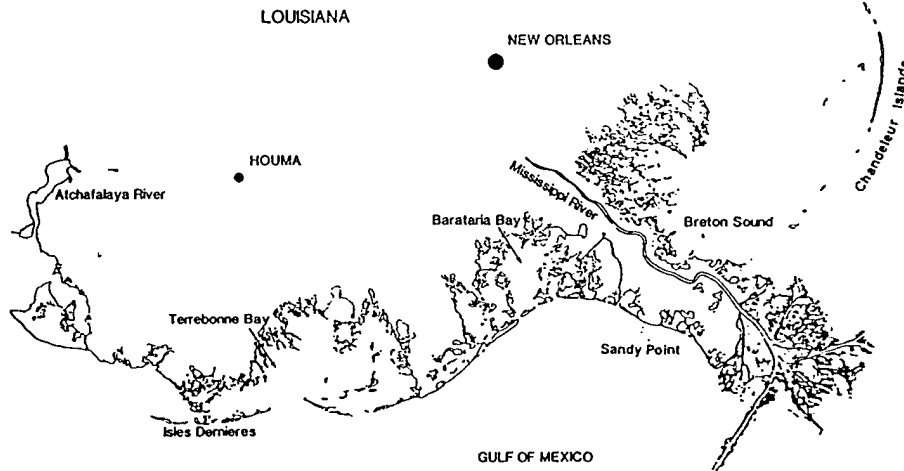

Fig. 2. Map of the southern Louisiana deltaic plain. The U.S. Geological Survey investigations of barrier island erosion and wetland loss cover regions east and west of the Mississippi River Delta.

changes. The study is divided into three main parts:

- Investigate the geologic framework of the Mississippi River deltaic plain (Fig. 3) where the barrier islands have formed and migrated landward. This involves using sediment cores and geophysical profiles to provide a broad regional understanding of the historical development of the barrier islands and a conceptual view of the processes of barrier island erosion. Comparisons of archival maps and photographs of the coast (from the past 135 years) are yielding accurate measurements of the geomorphic changes taking place (Fig. 4).
- Develop a better quantitative understanding of the processes responsible for erosion. The focus has been on only a few of the many physical processes, including relative sea level rise, over-

wash, net offshore sediment transport, and gradients of sediment transport along the length of the shoreline. Careful analyses of tide gauge records show a progressive rise in relative sea level over the entire region, with local rates exceeding 1 cm/year (Penland et al. 1987, 1989). Most of this rise is due to compaction and subsidence of the recent deltaic sediments. A series of field experiments and modeling efforts is being undertaken (e.g., direct measurements of the waves that wash over the Isles Dernieres barrier islands during winter storms and hurricanes).

- Assemble the research results as digital data sets, atlases, and technical reports for use by coastal scientists, planners, and engineers. Applications of the study results include developing better techniques for determining the rate

Fig. 3. A succession of six Mississippi River deltaic complexes has been deposited over the past 7,000 years because of channel switching by the river. (Adapted from Frazier 1967.)

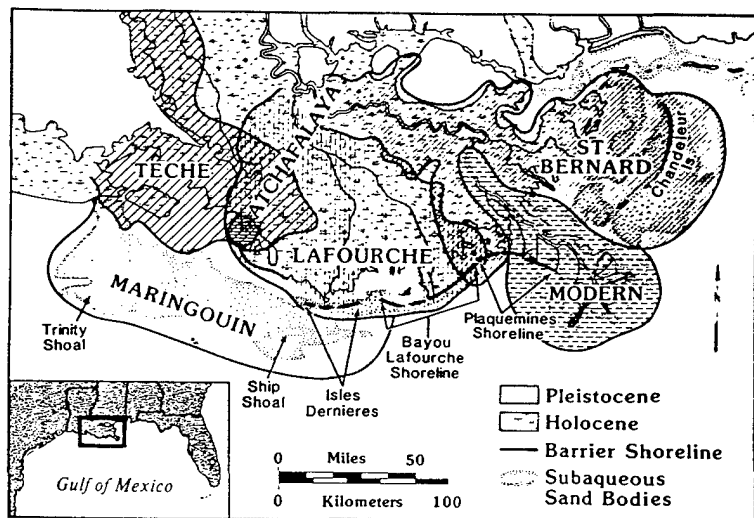

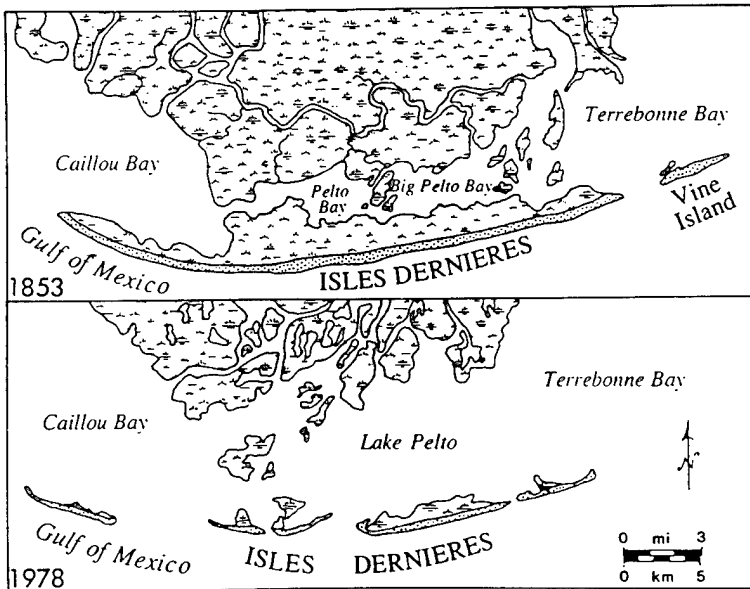

**Fig. 4.** Widespread erosion and deterioration of the Isles Dernieres barrier island arc since 1853 resulted from rapid rise in relative sea level, lack of sediment, and frequent storm effects on the coast.

at which artificially nourished beaches should be replenished and predicting future shoreline erosion so coastal planners can plan construction at a safe distance landward from the eroding shoreline.

### Louisiana Wetlands Loss Study

Of the 48 conterminous States, Louisiana has 25% of the vegetated wetlands and 40% of the tidal wetlands. These coastal wetlands, including the associated bay and estuarine environments, sup-

port renewable natural resources estimated at a value of \$1 billion per year. However, an estimated 80% of the Nation's tidal wetlands area loss has occurred in Louisiana. The areas of greatest loss are in the modern Mississippi River Delta and the Barataria and Terrebonne basins to the west (Fig. 5). Map comparisons by several scientists have been used to show that wetlands loss has steadily increased during the 20th century to an estimated 100 km<sup>2</sup>/year by 1978, the latest year for which detailed measurements are available. If this rate of wetland loss continues, the U.S. Army Corps

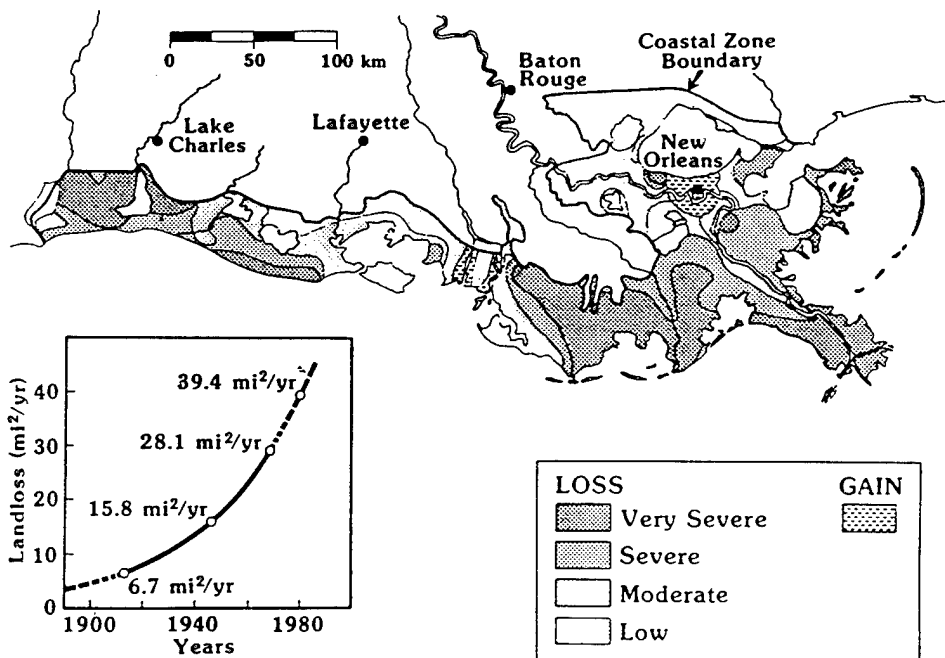

**Fig. 5.** Map showing the areal distribution and wetland loss rates for coastal Louisiana (adapted from Gagliano et al. 1981).

of Engineers estimates that in the next 50 years nearly 1 million acres of Louisiana wetlands will be converted to open water.

Conceived as a natural extension of the Barrier Island Erosion Study, the USGS study began in late 1988 in cooperation with the U.S. Fish and Wildlife Service (FWS) and Louisiana State agencies. Emphasis is on understanding the critical physical processes that cause the extreme rate of wetlands loss in coastal Louisiana and identifying the best management practices to address those losses.

This USGS and FWS wetlands study includes four parts: (1) baseline data is being compiled and entered into a computer-based geographic information system; (2) research is being conducted on a basin scale to understand some of the critical processes causing wetlands loss; (3) at specific sites, research is being conducted on the effects and utility of various wetlands management activities on the processes; and (4) the information and results from these studies will be relayed to the user community by means of reports, maps, and workshops.

The wetlands study elements dealing with research on some of the critical physical processes are being undertaken by USGS scientists as well as scientists at the Louisiana Geological Survey and Louisiana State University under contract with the USGS. Field studies will be conducted in two separate hydrologic basins, one sediment-rich and the other sediment-poor, in order to compare and contrast the dominant processes in each. Investigations are now under way in the sediment-poor Terrebonne basin-Timbalier Bay and parts of the Barataria basin (Fig. 2); field studies in the sediment-rich Atchafalaya basin will start in 1991. Research elements under investigation for each basin include:

- meteorological forcing events,
- fine-grained sediment dispersal,
- saltwater and freshwater dispersal,
- physical processes of marsh deterioration,
- wetlands soil development, and
- subsidence-soil compaction.

In addition, a study contracted to Coastal Environments, Inc., is examining the effects of small-scale freshwater diversions from the Mississippi River on brackish marshes adjacent to the levees. The duration of the USGS-FWS wetlands study is expected to be 6 years.

## Southern Lake Michigan Erosion Study

Over the past several years, fluctuating water levels in the Great Lakes, combined with storm waves and surge flooding, have caused significant and widespread coastal erosion and damage, particularly in urban areas such as Chicago. The USGS, working closely with the State geological surveys of Illinois and Indiana, recently completed the second year of a planned 5-year investigation of the shoreline of southern Lake Michigan. This study included surveying the coast and nearshore areas to (1) assess the extent of historic erosion, (2) investigate the geologic factors controlling the magnitude and range of water level fluctuations in the recent geologic past, (3) locate offshore sand bodies for use as fill to rebuild beaches and damaged portions of the shore, and (4) measure sediment transport processes throughout all seasons of the year.

## Alabama-Mississippi Erosion and Pollution Study

As in much of Louisiana, the Alabama-Mississippi coastal region is a dynamic system of coastal barriers, tidal inlets, wetlands, and large bays and estuaries that are undergoing environmental change due to natural and human activities. In response to the physical changes taking place, the USGS, in cooperation with the two State geological surveys, is undertaking a 5-year study focused on understanding the geologic processes that cause erosion and movement of fine-grained sediments and pollutants in the coastal zone. The first year of effort, fiscal year 1990, will concentrate on deciphering the geologic framework of the Alabama-Mississippi coastal region.

## Summary

In addition to the four studies currently under way in USGS's Coastal Geology Program, several other activities are in progress. As directed by Public Law 100-220, USGS and the National Oceanic and Atmospheric Administration have developed a plan for conducting geologic studies along, and remapping the coastal zone of, the U.S. portion of the Great Lakes. This plan, submitted to Congress in December 1989, recommends a 10-year effort of phased surveys and would include research contributions by agencies in each of the affected

States. To date, Congress has not provided funds for implementing this study.

Congress has also directed USGS to formulate a plan to extend and expand the present regional coastal studies into a research program of national scope. This effort is under way and includes obtaining recommendations from other Federal agencies as well as the appropriate agencies in each of the coastal States. This plan was submitted to Congress in June 1990.

## References

- Frazier, D. E. 1967. Recent deltaic deposits of the Mississippi River—their development and chronology. Pages 287–315 in *Transactions of the Gulf Coast Association of Geological Societies*, Vol. 17.
- Gagliano, S. M., K. J. Meyer-Arendt, and K. M. Wicker. 1981. Pages 295–300 in *Land loss in the Mississippi River deltaic plain: Transactions of the Gulf Coast Association of Geological Societies*. Vol. 31.
- Penland, S., K. E. Ramsey, R. A. McBride, T. F. Moslow, and K. A. Westphal. 1989. Relative sea level rise and subsidence in Louisiana and the Gulf of Mexico. *La. Geol. Surv. Tech. Rep.* 3. 65 pp.
- Penland, S., J. R. Suter, and R. A. McBride. 1987. Delta plain development and sea level history in the Terrebonne coastal region, Louisiana. Pages 1689–1705 in N. C. Kraus, ed. *Coastal Sediments '87*. American Society of Civil Engineers.

# Marine Wetland Mapping and Monitoring in Florida

by

Kenneth Haddad

*Marine Research Institute  
Florida Department of Natural Resources  
100 Eighth Avenue, S.E.  
St. Petersburg, Florida 33701*

**ABSTRACT.**—The Department of Natural Resources, Florida Marine Research Institute, has implemented a program of mapping and monitoring Florida's coastal marine wetland habitat. Because of Florida's extensive coastline and the need for timely monitoring, Landsat Thematic Mapper (TM) satellite data have been used as the base for the mapping effort. Aerial photography is used for seagrass mapping; the photointerpreted results are digitized into the USGS quad-rectified TM base map. The TM data are processed to distinguish the marine and estuarine emergent vegetation. Although the protocol and techniques for the mapping effort have begun and an initial mapping effort has been completed, a fully established monitoring effort is still in a developmental stage. The success of this program is predicated on the flexibility of using multiple sources of data with a resultant digital product.

The State of Florida has one of the most extensive coastlines in the United States and climatically ranges from tropical and subtropical to temperate. This has resulted in a complex and diverse assemblage of species and habitats that are often unique and fragile. Florida's population growth is one of the highest in the Nation, with more than 80% of State inhabitants living within 16 km of the coast. The resultant effects on marine and estuarine resources, although at times obvious, have been poorly understood, rarely quantified, and assumed to be far-reaching.

## *System Analyses and Management*

With such a diverse richness of Florida's marine resources and a resultant diverse group of users, management of the State's marine resources is not an easy task. The difficulty is compounded by the State's rapid growth and the currently unquantifiable effect of this growth on marine resources.

A primary goal of the Florida Department of Natural Resources, Marine Research Institute (FMRI), is to conduct research and synthesize that research into information that can be used to make sound resource management decisions. Most marine resource management strategies and actions in Florida have been oriented to single species. As

technical data on the status and trends of coastal and marine resources have become available, it has become evident that this targeted approach to management is inadequate over the long term. Habitat has been lost, species abundance has declined, polluted waters have reduced shellfish harvest areas, and fisheries have been closed.

This realization has stimulated the evolution of an ecosystem approach to resource management. This kind of approach is based on the fact that without an understanding of species' interactions, communities, community interactions, and cumulative environmental impacts (natural and human-induced), management actions will often be reactive rather than preventive or corrective.

## **Habitat Mapping and Trend Analyses**

A first step in building a digital ecosystem data base is the determination of the extent and location of critical habitat. In 1983, FMRI, through the National Oceanic and Atmospheric Administration (NOAA) Office of Ocean and Coastal Resource Management and Florida's Department of Environmental Regulation, initiated a program to map and monitor coastal wetlands and submerged

habitat, including salt marshes, mangroves, submerged aquatics, oyster reefs, and unconsolidated bottom. With such an expansive coastline in Florida, we analyzed unconventional methods for the mapping effort.

Initially, we evaluated mapping techniques to determine cost, accuracy, and production-time comparisons between digital image processing of Landsat Thematic Mapper (TM) data and cartographic aerial photography methods. A 69% cost saving and 83% production-time reduction was realized with TM data (Haddad and Harris 1985a). We also determined that aerial photography was often needed for photointerpretation and digitization into the resource map when submerged habitats were being mapped (Haddad and Harris 1985b). In marine wetlands, classification accuracy for both aerial photographs and TM data was >90%. Based on these results, FMRI began systematically mapping Florida's estuarine and marine wetlands, excluding the Everglades National Park and Biscayne Bay. That effort began in 1984, was completed with updates in 1986, and required about 2 years of effort (1 year = 2080 hours).

### *Trend Analyses*

Habitat trend analyses also have been completed for selected areas of the State from the 1940's to the present. A major conclusion from the trend analyses is that submerged aquatics have often experienced the greatest loss, and this loss is no longer due to mechanical effects, but rather to changes in water quality. This conclusion is supported by the fact that submerged aquatic losses often occur in deeper waters within estuaries, suggesting insufficient light penetration as a causative factor. Loss of marsh and mangrove has substantially decreased in Florida, and where sufficient protective measures have been established, increases in aerial extent have been observed (Haddad and Hoffman 1985b).

## **Mapping Techniques**

We needed to decide on a base map (the digital map to which all data are referenced) early in the program. As is common in many areas, base maps were not available in digital form on a statewide basis, and the cost of digitization was prohibitive. Therefore, the only reasonable approach was to make the TM data the base map, and any additional map layers (i.e., seagrasses, oysters) would be digitally rectified to that base.

## *Geographic Referencing*

TM data consist of six spectral layers of information for each 1/4 acre (30 × 30 m) on the ground and a thermal band with 4-acre resolution. Each spectral band is rectified to 7.5-min U.S. Geological Survey (USGS) quadrangles in a UTM projection by using a bilinear interpolation technique. Welch et al. (1985) determined that this type of process can achieve accuracy standards for 1:50,000-scale maps and approach the standards for 1:24,000-scale maps. Rectification of the individual spectral bands, rather than the finished product, is standard because of the need to continually return to the raw data for additional analyses.

## *Image Analyses*

We have not developed a rigid protocol for statistical analysis of the satellite imagery data, but workable techniques have been standardized. Numerous types of statistics have been tested for their ability to classify marine and estuarine wetlands and for computer processing times. Standard classifiers, such as the maximum likelihood, which can use either supervised or unsupervised approaches to generate statistical clusters, are processing-intensive and cumbersome in a production operation. This observation is based on our specific needs relative to coastal wetlands and does not consider the use of this approach for general mapping needs. With this type of algorithm, and most algorithms in use, the higher the spatial resolution the more difficult it is to resolve confusion within and among classes. At some point, human intervention with a photointerpretive-like process is necessary.

Our approach has been to use a rapid parallel-piped type of classifier to initially process the data into 256 classes. The classifier is run on the green, red, and near-infrared, and the red, near-infrared, and mid-infrared TM spectral bands, respectively, to generate two statistical images. The first image is pictorially similar to a color-infrared photograph and can be image-interpreted by identifying those clusters that represent the wetland categories of interest. We found that it is often advantageous to use the second image because of its accentuation on the infrared bands. In particular, we have found that the mid-infrared band enhances our ability to differentiate wetlands. In many cases, we use both images to selectively differentiate categories of

interest, with the results being a third image composed of the best clusters from each image.

Although this approach is rapid and effective it still does not meet accuracy standards expected for wetlands mapping when compared with interpretation of photographs at similar spatial resolutions. The associative and subjective analyses performed by a photointerpreter are not yet reproducible statistically. On the other hand, use of the TM mid-infrared band can have advantages in certain analyses where identification of different levels of moisture content enhance the ability to differentiate wetland types beyond those observable in an infrared photograph.

Once the images are clustered as best as can be statistically accomplished, National High Altitude Mapping Program aerial photographs, existing National Wetlands Inventory (NWI) maps, ground truthing, and many other data sources are used to identify or confirm clusters that are not pure to a given wetland type. For example, some clusters representing mangroves may be confused with a wet orange grove or a freshwater wetland, resulting in a 70% identification accuracy. The remote-sensing literature has many examples of this type of confusion, and it reports the statistical inaccuracies of this type of analysis. The literature reflects an academic approach to image analyses and not a production approach. We routinely "fix" the confused clusters by using simple digital manipulations based on the interpreter's assessment of the data. Orange groves and freshwater wetlands are reclassified into appropriate categories, often increasing identification accuracies for mangroves >95%.

This flexible and rapid approach to wetlands mapping results in a highly accurate product, but only for wetlands. We routinely produce a final map product that merges the wetland types with the original color-infraredlike image. By providing this pictorial image for the background data, the user is able to orient to the image and eliminate the need for a summary presentation of data not classified as wetlands.

### *Seagrasses*

Seagrass mapping presents special problems for satellite image analyses. Landsat only collects an image over a given area once every 16 days. This means that conditions conducive to mapping must all coincide on that given day. If the water is clear and clouds do not obscure the area, there is a good potential for using imagery for seagrass mapping.

We have not found any statistical analyses that adequately define seagrasses, although we have had success in limited cases. Variations in water clarity, water depth, and sediment type preclude the use of standard spectral analyses. The image must be manually photointerpreted in either the blue, green, or red spectral bands. Because of these obstacles we commonly use aerial photography (either existing or contractually flown) to map seagrasses. The photographs are photointerpreted and rectified to the Landsat base map, and the seagrass coverage is conventionally digitized as wetland types into the wetlands data base.

## Habitat Trend Analyses Techniques

Trend analyses for coastal wetlands can be conducted with numerous techniques. The creation of data for actual analyses must be done with caution because in most cases it is difficult to separate errors in classification from actual habitat changes. Trend analyses cannot be conducted on data that use different classification systems that have not been normalized. In fact, it is very difficult to compare data that have been interpreted by different investigators that use the same classification system if tedious interpretive calibrations are not conducted. If done properly, habitat trend analyses can provide valuable insights on the effects of habitat management regulations and the changes in the resources that use those habitats.

### *Historical Data*

Historical analyses have been accomplished for many areas in Florida by photointerpreting archived photographs from the 1930's to 1970's. We rectify the interpreted data to the Landsat base map and table-digitize them into a separate data layer. When we use aerial photography, the interpretations often must be transferred to a USGS quadrangle to geo-correct the data for spatial inconsistencies before digitization. We can often bypass this step by using a three-point triangulation method when digitizing off the photographs. When positional deviations are observed, new points are picked and the digitization process is continued. If the interpretation of the historical photographs is compatible with the TM analyses, then trend analyses can be conducted. We have not attempted to compare historical Landsat Multipectral Scanner (MSS) data with the recent TM data because of the



uncertainties introduced by spectral and spatial resolution differences.

### *Contemporary Data*

When building a data base for trend analyses, it is important to create an accurate habitat data layer with which historical and future data will be compared. We concluded that contemporary data should be that layer. Contemporary data can be ground-truthed and corrected for errors in classification, which cannot be done for historical photographs. This also gives the investigator a "feel" for the area and increases the potential for accurate interpretation of historical photos. By expending initial efforts in the creation of the contemporary data, a considerable reduction in effort is realized when developing the historical data base and conducting future map updates.

### *Data-base Updates*

One approach to updating the habitat data base is to remap a given area to compare with the original maps. That process is time-consuming. We have developed a technique that takes advantage of the fact that TM data are digital. When working with a focused data base, such as coastal wetlands, we process the new TM data into 256 classes, as previously described. This produces an image, rectified to the base map, that can be manipulated to update the original map. The original data are used to mask a given habitat, which is then compared in a very rudimentary way with the new TM image. For example, when updating mangroves, we would use the original coverage of mangroves to locate those areas in the new TM image that should contain mangroves. Mangroves, in the new image, can be expected to fall within a specific range of statistical clusters, and those clusters that fall outside that range are identified as potential areas of change. These areas can then be visually assessed for changes. In theory, an inverse process can be used to identify areas of mangrove growth, but we have not tested this approach because of insignificant amounts of growth in wetlands since our initial mapping effort with TM data.

### **Problems with Disparate Data**

Figures 1a–1c depict the results of the updating process, except that we have used mangroves digitized from a 1982 NWI aerial photographic mapping effort as the mask to a 1987 TM image to

show both the process and, if using disparate data sources, the problems. The observed areas of change represent differences in final product resolution, habitat classifications, and real changes in habitat. Figure 1a is a general map of a coastal area of Tampa Bay, Florida. The data have been consolidated to three classes and are a digital representation of the 1982 NWI map. Figure 1b represents the statistically clustered 1987 TM data for the area of mangroves delineated in the 1982 data. Figure 1c shows those areas that were labeled as mangrove in 1982, but not classified as mangrove in 1987. Quantitatively, the area was reduced from 2,952 ha of mangrove to 2,564 ha, a 13% loss. However, when investigating the changes, it becomes obvious that a large portion of that change is not real and represents differences in interpretation techniques and classification systems. Many of the smaller areas of change are actually uplands within the mangrove complex. These types of features are averaged by the photointerpreter to become mangroves, even though the photography was at the 1:24,000 scale. In the photointerpretation and digitization process it becomes impractical and costly to try to delineate these features at that scale. The photointerpreter makes a conscious decision to delineate them or they are lumped into the mangrove classes; digital processing automatically maintains their separation.

The use of classification systems also contributes to discrepancies in updating data. The NWI maps are based on the Cowardin et al. (1979) system, whereas the State of Florida uses a modified Anderson (1976) system tailored to State needs. In Fig. 1c, a 162-ha area defined by NWI as mangrove, falls outside the spectral clusters we consider mangrove. In fact, this is a salt flat that has  $\leq 30\%$  mangrove and would never be classified as mangrove. To confuse the process further, this same area was called the equivalent of a salt flat in the 1950 NWI analyses, and thus shows a misleading increase of 162 ha of mangroves within the same classification system.

The point to be made is this—trend analyses must be conducted with caution and with a full evaluation and understanding of the data being compared. In fact, of the 388-ha change between 1982 and 1987, less than 17 ha are due to real change (<1% change). If the original image used was TM rather than NWI, then the data updating would not have the problems that have been identified. This does not indicate that one process is better than the other, just that they are different.

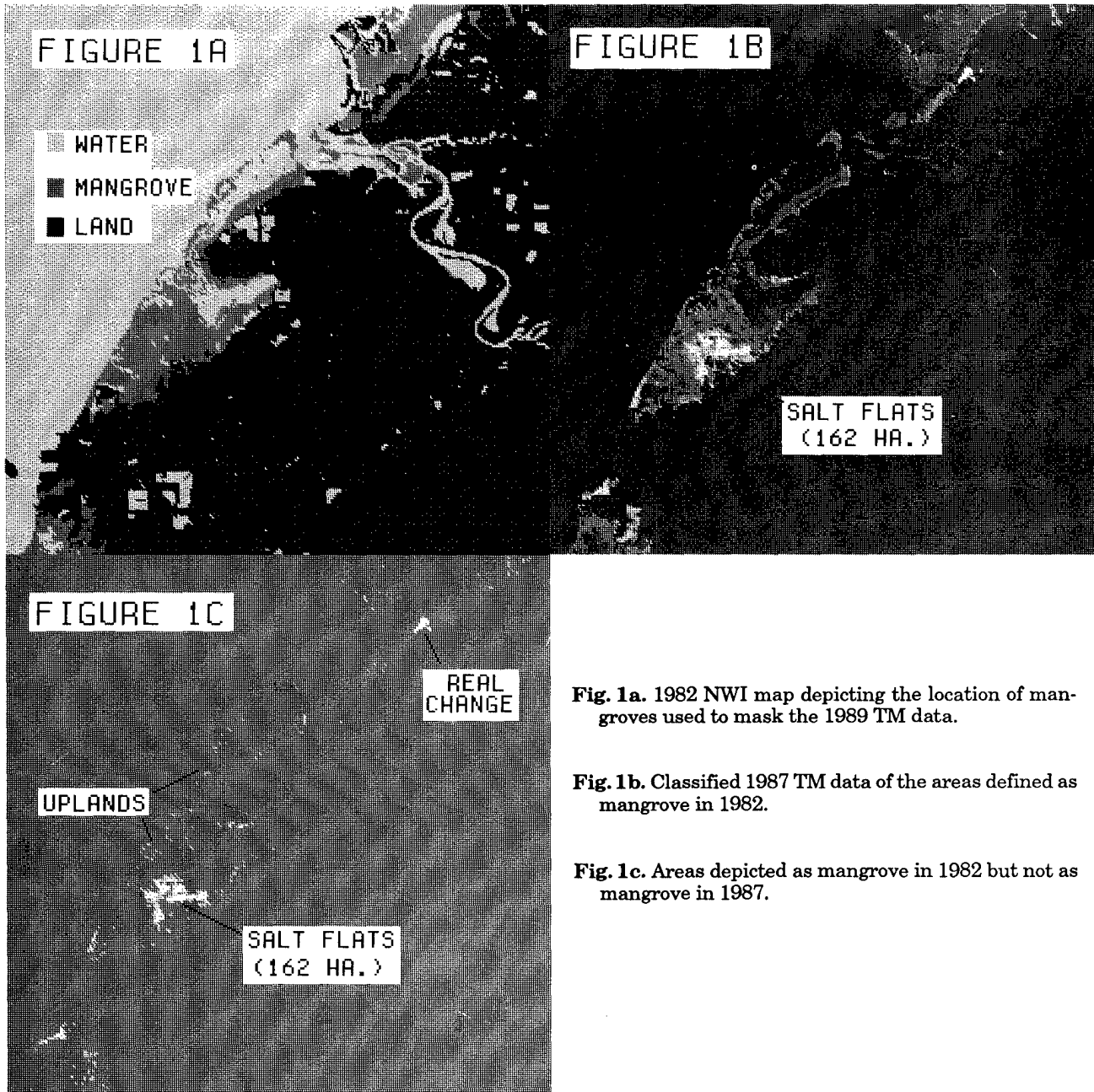

**Fig. 1a.** 1982 NWI map depicting the location of mangroves used to mask the 1989 TM data.

**Fig. 1b.** Classified 1987 TM data of the areas defined as mangrove in 1982.

**Fig. 1c.** Areas depicted as mangrove in 1982 but not as mangrove in 1987.

*Classification Systems*

The importance of the classification system cannot be underestimated when using satellite image processing for habitat delineation. This is something that must be addressed in the initial stages of the mapping program. Because we have been primarily mapping coastal wetlands, we have chosen to tailor our classification to Florida wetlands

by name. Thus, we name a salt marsh complex a salt marsh, and if we go to the next level of delineation we would name *Juncus* and *Spartina* as components of that complex. Our classification, at that point, could be cross-referenced with either the NWI Cowardin et al. (1979) system or the Anderson (1976) system. Because we are working with raster data at 30-m spatial resolution, we have categories that consist of marsh and water.

These areas are often presented as a marsh/water category, which is not used in most classification systems.

In Florida, we have observed that the TM analyses can be better tuned to the Anderson system and can have major discrepancies with the Cowardin system. It is best to determine the limits of the classification systems relative to TM processing and develop a hybrid system. If this is not done, much effort can be spent attempting to force a classification of the data, thus reducing the ability to efficiently conduct trend analyses.

## Conclusions

The Florida Marine Research Institute has developed and implemented a coastal mapping effort designed for efficient and cost-effective mapping and monitoring of Florida's geographically expansive coastal wetlands. A combination of Landsat imagery, aerial photography, ground truthing, and ancillary map data is used to produce digital maps from a Landsat TM map base. I have described, in a very general presentation, the techniques and concepts we employ in the map-making and subsequent habitat trend analyses. The success of this effort has been based on the flexibility built into the standardization of the mapping process.

Many issues, such as ground truthing and digital and hard-copy data distribution, have not been discussed. All require substantial planning and can become major operational components of an effective program. We also have evaluated SPOT satellite data for mapping efficiency, and we use SPOT data when higher resolution mapping is required. The spectral superiority (particularly the mid-infrared bands) and lower costs of Landsat TM data make its use more advantageous for large geographic areas.

Although our habitat mapping effort is important, it has little long-term meaning if the habitat

is not considered as part of an ecosystem. The wetlands are just one layer of information, out of many, that we are building into the Marine Resource Geographic Information System. Linkage to dredge and fill permits and other types of permits, which will allow us to reconstruct permitted habitat losses that cannot be mapped, is being investigated. Concurrent with our mapping efforts, we are conducting field research to assess species utilization and production within the different habitats. All of these efforts will eventually provide the information necessary to implement an ecosystem approach to coastal resource management.

## References

- Anderson, J. R., E. E. Hardy, J. T. Roach, and R. E. Witmer. 1976. A land use and land cover classification system for use with remote sensor data. U.S. Geol. Surv. Prof. Pap. 964. 28 pp.
- Cowardin, L. M., V. Carter, F. C. Golet, and E. T. LaRoe. 1979. Classifications of wetlands and deepwater habitats of the United States. U.S. Fish Wildl. Serv., FWS/OBS-79/31. 103 pp.
- Haddad, K. D., and B. A. Harris. 1985a. Use of remote sensing to assess estuarine habitats. Pages 662-675 in O. T. Magoon, H. Converse, D. Minor, D. Clark, and L. T. Tobin, eds. Coastal zone '85. Proceedings of the fourth symposium on coastal and ocean management. Vol. 1. American Society of Civil Engineers, New York.
- Haddad, K. D., and B. A. Harris. 1985b. Assessment and trends of Florida's marine fisheries habitat: an integration of aerial photography and thematic mapper imagery. Pages 130-138 in S. K. Mengel and D. B. Morrison, eds. Machine processing of remotely sensed data. Purdue University, West Lafayette, Ind. 370 pp.
- Welch, R., T. R. Jordon, and M. Ehlers. 1985. Comparative evaluation of geodetic accuracy and cartographic potential of Landsat-4 and Landsat-5 thematic mapper image data. Photogram. Eng. Remote Sens. 51(11):1799-1812.

# Satellite Data and Geographic Information Systems Technology Applications to Wetlands Mapping

by

Richard H. Sinclair, Jr., Mark R. Graves, and Jack K. Stoll

*U.S. Army Engineer Waterways Experiment Station  
Environmental Laboratory (EN-B)  
3909 Halls Ferry Road  
Vicksburg, Mississippi 39180*

**ABSTRACT.**—Satellite digital images and geographic spatial data-base technology are well suited for mapping and analysis of the vast, complex wetland environments of the lower Mississippi River Valley. We applied these technological resources on two wetlands mapping projects. The first mapping project, completed for the U.S. Fish and Wildlife Service (FWS), illustrates the quantitative value of spatial seasonal data for mallard (*Anas platyrhynchos*) habitat analysis. Crops and forested areas mapped from a summer Landsat Thematic Mapper scene were combined with flooded areas mapped from a winter scene to define wintering habitat types and distributions. Results of this analysis were used by FWS's National Wetlands Research Center's regional office in Vicksburg, Mississippi, to determine the reliability of a Habitat Suitability Index model for mallards wintering in the lower Mississippi River Valley. Satellite resources are often dominantly competitive or, in fact, the only affordable solution to reliable seasonal data for habitat analysis of large geographic areas.

The second project illustrates the efficiency of digital map data-base development to satisfy multiple requirements within the U.S. Army Corps of Engineers for wetlands regulation and impact analysis. The specific area involved is the Yazoo River basin floodplain, which is parallel to the Mississippi River in west-central Mississippi. The basin covers all or parts of a 20-county region. Hydric (wetland) and nonhydric (nonwetland) soils are being digitized from Soil Conservation Service soil survey photo map sheets. Results of this effort will be a high resolution, georeferenced digital data base and accompanying acreage statistics for wetland and nonwetland areas.

## Mallard Wintering Habitat Study

### *Landsat Thematic Mapper Land Cover Mapping and Habitat Analysis in the Lower Mississippi Valley*

This study was conducted by the U.S. Army engineer, Waterways Experiment Station, Environmental Laboratory (WES-EL) for the U.S. Fish and Wildlife Service (FWS). Our objective was to derive georeferenced spatial data on mal-

lard (*Anas platyrhynchos*) wintering habitat variables in the lower Mississippi River Valley (LMV) from Landsat digital images.

The scope of work completed by WES-EL for the FWS included the analysis of two seasonal Landsat Thematic Mapper (TM) scenes. A summer scene was selected in August 1988 for mapping forests and agricultural cropland classes. A winter scene was selected in January 1989 for mapping typical surface hydrology (permanent water bodies and seasonal flooding) that exists during the mallard's southern migration. Statistical land cover information was developed as

input for a Habitat Suitability Index (HSI) model of mallard wintering habitat in the LMV (Allen 1986). The FWS's objective was to use Landsat TM data as a means to validate the mallard HSI model. The FWS scientists required land cover statistics for 16-km<sup>2</sup> sample areas within the project boundaries, as the HSI model specifies an 8-km mallard foraging radius (Allen 1986). FWS personnel selected 25 sample areas from the summer scene based on statistics from 49 sample areas that define the study area. Two of the 25 sample areas were selected from a region bordering the 7 by 7 matrix making up the original 49 sample areas. These two areas were added so that densely forested land cover types would be included in the analyses. Color-coded maps of land cover classes were plotted for each of the 25 selected sample areas. These maps were used to record a FWS census (aerial transect) of the existing mallard population near the time of data acquisition. Statistics, including area calculations for each class, were developed for the same 25 sample areas (measuring 16 km<sup>2</sup>) in both scenes. Our final results consisted of acreage data for flooded forest, flooded rice fields, and other flooded cropland. These results were derived by overlaying the classified data for the two Landsat scenes and extracting acreage where forests and crop classes from the summer scene coincided spatially with flooded areas in the winter scene. Three sets of plots were produced for the 25 sample areas to illustrate the results for all stages in the analyses.

### Data Sources

The United States' Landsat 4 and 5 satellites carry the TM sensor package as the principal data-gathering instrument. Radiant energy is recorded in seven wavelength bands. Six of the bands occur in the 0.45  $\mu\text{m}$  (ultraviolet radiation) to 2.35  $\mu\text{m}$  (reflected infrared radiation) portion of the electromagnetic spectrum. Recorded data from these channels have a spatial resolution of 30 m. The remaining band (band 6) is in the 10.4 to 12.5  $\mu\text{m}$  (thermal infrared) portion of the spectrum and is recorded with a spatial resolution of 120 m.

The project study area was located within the correct Landsat TM frame by using the Landsat Worldwide Reference Systems Map at Path/Row 23,37 (U.S. Geological Survey 1982). FWS personnel acquired both Landsat TM scenes from the Earth Observation Satellite Company in Lanham, Maryland. The data were received on computer-

compatible tapes in 6,250 bits per inch, band-sequential format. The tapes were generated by the Thematic Mapper Image Processing System at the National Aeronautics and Space Administration's (NASA) Goddard Space Flight Center in Greenbelt, Maryland.

U.S. Geological Survey (USGS) 1:24,000-scale maps were used to geometrically rectify the raw Landsat TM data. The scene was centered near Greenville in western Mississippi, and covered parts of Mississippi, Louisiana, and Arkansas. The scene size was about 2,000 km<sup>2</sup>. Eighteen USGS map sheets were required to locate about 100 reference (control) points distributed uniformly throughout the scene.

All Landsat data were georeferenced to the Universal Transverse Mercator (UTM) projection (zone 15), with a grid resolution of 30 m<sup>2</sup>. The final data file represents a matrix of 5,534 lines (vertical) by 5,368 elements (horizontal). The array extracted for the 7- by 7-matrix analysis has the following UTM coordinates: upper left corner Easting 605970, Northing 3751030; and the lower right corner Easting 767010, Northing 3585010. This coordinate space does not include all the area covered by the two additional sample sites selected at a later date.

Color aerial photography, obtained in winter 1984, and information gathered from subsequent low-altitude aerial reconnaissance flights were compared with the summer Landsat scene classification. The photographs were particularly useful in differentiating a small percentage of rice fields confused with adjacent forestland in the unsupervised Landsat data analysis.

### Computer Hardware and Software Assets

With the exception of reformatting in the raw data tapes, all image data analyses for this project were completed on one 386-based personal computer workstation. The personal computer workstation is enhanced for image processing and geographic information system (GIS) applications by a number of specific peripheral devices and add-on computer cards, including the following: an Opus Systems CLIPPER 32-bit microprocessor board with four megabytes of random access memory, operating in a UNIX environment at a clock speed in excess of 30 MHz and executing 4 to 5 million instructions per second; a Revolution Number Nine 512 by 512 by 32-bit image board and 19-inch RGB graphics display monitor; an Archive 1/4-inch (60-megabyte cartridge) streaming tape backup

system; a GTCO 24- × 36-inch digitizing tablet; and dual Maxtor 320-megabyte hard disk drives. Other peripherals were used in generating output products, including a Versatec 36-inch color electrostatic plotter, Matrix Instruments digital and analog cameras, and a Toyo thermal screen dump 11-inch plotter.

All image analyses and GIS operations were conducted with the Earth Resources Laboratory (now the Science and Technology Laboratory) Applications Software (ELAS) developed by NASA. Staff at the Waterways Experiment Station Environmental Laboratory completed the first port of ELAS to the personal computer environment, first executing under the MS/DOS operating system and later under the UNIX operating system on the CLIPPER microprocessor. ELAS is a geobased information system originally designed for processing and analyzing digital imagery acquired by multispectral scanners on aircraft or spacecraft, and data digitized from maps. Digitized map data include polygon data digitized from thematic maps (e.g., soils, forest) and digitized topographic data such as those distributed by the National Cartographic Information Center.

### **Landsat Thematic Mapper Data Classification and Analysis of Results**

The scope of the image classification and analysis includes the procedures used to input the raw satellite digital image data, converting the image data into meaningful terrestrial classes, and analysis of the classified data from both Landsat scenes.

*Reformatting Landsat Thematic Mapper and computer compatible tape data.* Raw Landsat TM data were read from the tapes into the ELAS operating environment by using the module Reformat Thematic Mapper Image Processing System. The individual channels of the data were displayed in black and white and in true and false color-composite format to assess the quality of the digital imagery. The summer scene was judged to be of marginal quality, as scattered clouds were present throughout most of the scene and the blue and green bands (TM bands 1 and 2) exhibited a blurring effect attributed to high humidity during the time of satellite data acquisition. The winter scene was of relatively high quality except for a single band of very thin, wispy, high-altitude clouds oriented east-west across the northern portion of the data. Better-quality data usually are obtained during the winter months (if cloud cover is absent) because the humidity is normally lower during

colder temperatures. This tends to lessen the scattering effect of the atmosphere on visible wavelengths.

*Image processing and analysis.* After the individual channels were viewed on an image display device, we made decisions as to which data channels would be used for gathering spectral cluster statistics over the images. The blue band was discarded from both image analyses because of the excessive haze in the summer scene and because it did not contribute significantly to surface water delineation in the winter scene. After selection of the proper channels, spectral cluster statistics for the summer image were developed with both supervised and unsupervised algorithms. Unsupervised statistics were gathered with the ELAS modules Normal Variation and TM Trainer. The Normal Variation module is designed to compute the normal variation of digital count data (reflectance values from 0-255) found within selected channels of the raster image data. Resulting parabolic coefficients for each channel are stored in an ELAS subfile for use by the ELAS module TM Trainer. TM Trainer uses a 3- by 3-pixel window to search the raw data for homogeneous training fields. The coefficients computed by Normal Variation are used to model expected variations within the data. A 3 by 3 field in each channel is considered to be homogeneous if its variance falls below the parabola for that channel (National Aeronautics and Space Administration 1989). If that field is then determined to be homogeneous in every channel, it is stored as one of the preliminary statistics. Once 60 fields have been collected, the two with the smallest-scaled distance are merged, opening one of the temporary statistic bins for collection of another field. Once this has happened, the process of searching for another statistic and merging the two most similar statistics is continued throughout the remainder of the input data. Once all input data have been processed, the final processing command is used to merge all of the statistics that remain in the 60 temporary bins until no two statistics have a scaled distance less than 4.

The supervised statistics for the summer scene were derived from field data gathered by FWS's National Wetlands Research Center Field Station in Vicksburg, and FWS's Patuxent Wildlife Research Center. Polygons were digitized that bounded spatial locations in the data corresponding to known land cover types. Statistics for the pixel values within these polygons were computed by using the ELAS module Supervised Training.

Because the analysis of the winter scene was limited to discriminating water bodies and flooded areas (surface hydrology classes), we decided that unsupervised statistics-gathering methods would be the most expedient and reliable.

We analyzed the final statistics (unsupervised and supervised) by comparing statistical distance measures. Specifically, we used the transformed divergence measurements, in conjunction with visual display analysis, as a basis for merging or deleting particular statistical clusters. Transformed divergence is a saturating function of divergence that has been demonstrated as helpful in measuring the average difference between two-class density functions (Swain and King 1973). We also used several ELAS modules that produced visual representations of multivariate statistics during examination of the statistics.

After configuring the final set of spectral cluster statistics, we used a minimum distance classification algorithm to assign each digital count (pixel reflectance value between 0 and 255) within the study area to one of the clusters. We used the ELAS module Classifier Minimum Distance to obtain the image spectral classification for the study area.

*Georeferencing the Landsat images.* We did geometric rectification to the UTM coordinate system after spectral clustering of the images to avoid any degradation of the computer-compatible tape data before statistical analysis. The georeferencing procedure consisted of finding easily recognizable surface features (such as road intersections) on the image data that were present on the USGS 1:24,000-scale quadrangle maps. We obtained the UTM coordinates of these points by manual digitizing procedures, while the image data coordinates (line and element values) were gathered by positioning the cursor over the feature and using ELAS module Common Display "read target" command. The 100 control points were evenly distributed through the entire study area. Once a relation was established between the image data and UTM coordinates, we derived a transformation equation through using the ELAS module Compute Mapping Coefficients. We used the resulting equation to transform the entire study area image file to the UTM coordinate projection. These procedures were applied separately to the summer and winter scenes.

*Merging Landsat Thematic Mapper classifications to obtain a habitat map.* We constructed the final habitat map by overlaying the classified summer and winter scene spatial data files. Land cover

classes, percent of area covered, and acreage calculations for the summer scene are presented in Table 1. Classes developed, percent of area covered, and acreage calculations for the winter flooding conditions are presented in Table 2, and habitat classes developed, percent of area covered, and acreage calculations for each class in the 7- by 7- matrix study area are presented in Table 3.

## Discussion

We encountered considerable difficulty in processing the summer Landsat imagery. Atmospheric conditions at the time of scene capture, coupled with poor crop conditions caused by a drought, made it difficult to distinguish between land cover types that should have been spectrally discrete. Relative humidity was excessive at the time of image capture; therefore, single and multiple scattering in the visible spectrum severely diminished the quality of the three visible bands (Landsat TM channels 1, 2, and 3). Because of severe drought conditions, most field crops were severely stressed. Only those fields that were well irrigated displayed a closed canopy condition at the time of image acquisition.

Optimal Landsat classifications are derived when researchers acquire satellite and ground-truth data at the same time. When high-quality

Table 1. *Summer land cover types and acreage calculations for the complete study area.*

Summer Land cover area calculations			
Class	Description	Percent	Acres
1	Agriculture, bare ground	2.7	84,173.5
2	Water	3.7	116,064.9
3	Forest	13.5	419,817.8
4	Sand	0.8	25,736.3
5	Cloud	3.6	110,984.6
6	Cloud shadow	1.4	42,339.7
7	Grass, shrub, scrub	4.0	122,754.6
8	Water edge	2.3	70,386.9
9	Agriculture, unknown	1.9	58,701.6
10	Agriculture, predominantly cotton	39.8	1,231,307.1
11	Agriculture, predominantly soybean	8.1	251,987.4
12	Agriculture, fallow	16.3	515,141.3
13	Agriculture, rice	1.5	48,012.9
<b>Total</b>			

Table 2. *Winter land cover types and acreage calculations for the complete study area.*

Winter Landsat Thematic Mapper land cover types and area calculations		
Class Description	Percent	Acres
1 Nonwater	86.9	2,693,000.8
2 Water	13.1	404,408.2
<b>Total</b>		

Landsat imagery does not coincide with ground-truth data, more accurate results may require the use of archive data from a previous year. Also, if separation of crop types is especially important for a satellite data study, crop calendars should be consulted in conjunction with local weather conditions when selecting imagery, so that spectral differences among land cover classes can be maximized.

## Yazoo Basin Wetlands Mapping

The WES-EL, Environmental Systems Division remote-sensing applications team is involved in a wetlands mapping project for the U.S. Army Corps of Engineers in the Vicksburg District. The objective of this project is to create a georeferenced digital wetlands data base for the Yazoo River basin in west-central Mississippi. The mapping is being completed to aid regulatory personnel in addressing requirements set forth in Section 404 of the Clean Water Act of 1977.

The project area covers about 4.5 million acres of predominantly agricultural land. The data base under development is a 20-county area in the Yazoo River basin, a major tributary to the Mississippi River. The work involves the acquisition of Soil Conservation Service (SCS) photomosaic soils maps for each of the 20 counties. An extensive reconnaissance of SCS soil types presented on these maps was made in the field by the authors and staff from SCS, the U.S. Environmental Protection Agency, and Vicksburg District personnel. Soil types were categorized as hydric or nonhydric. A consultant, who was formerly an SCS employee and the principal developer of the SCS hydric and nonhydric classification methodology, also accompanied personnel in the field. Based on this review, the hydric or nonhydric soils boundaries were traced on the photomosaic soils maps.

Table 3. *Final habitat types and acreage calculations for the complete study area. Winter and summer scene analyses are combined.*

Winter and summer final habitat classification			
Class	Percent	Description	Acres
1	93.3	Nonflooded	2,889,185.5
2	0.3	Flooded rice	8,269.8
3	4.7	Flooded agriculture (other)	146,661.6
4	1.7	Flooded forest	53,292.0
Subtotal			208,223.4
<b>Total</b>			<b>3,097,409.0</b>

These boundaries are digitized, displayed, and edited on a color video monitor, converted to grid cell format (raster), and put into the proper coordinate space in the GIS. Final operations are performed to adjust and edit data along map sheet boundaries in the GIS. County boundaries and project river reach boundaries are also digitized so that retrieval of wetland locations and size (acres) can be done by county or river reach.

### Source Data

The mosaics prepared for digitizing are composed of four SCS Soil Survey photo map sheets at a scale of 1:15,840 or 1:20,000, joined together. Georeferencing procedures are accomplished with USGS 1:62,500-scale quadrangles. All soils data are rectified to the UTM coordinate system and gridded at a resolution of 20 m.

### Computer Hardware and Software Assets

The personal computer workstation used in developing the digital map data base of Yazoo River basin wetlands has an identical configuration to that previously described for waterfowl habitat mapping. The remote sensing applications team within WES-EL has four such workstations. Operators of three digitizing workstations help complete work on 151 mosaics. The digitizing software used is the commercial software package from Earth Resources Data Analysis System.

### Data-base Development Methodology

A generalized description of the sequential steps required to develop the digital map data base and to calculate wetland acreage follows.



1. Aggregate hydric and nonhydric soils on individual SCS soil survey photo map sheets and assemble the mosaics.
2. Select georeferencing control points on mosaics and 1:62,500-scale USGS maps.
3. Digitize all hydric and nonhydric soil boundaries.
  - a. Map data are digitized at any one of the three personal computer workstations. Resulting digitizer files are copied onto 5.25-inch floppy disks and delivered to the data-base integration administrator.
  - b. Digitizer data files for individual maps (mosaics) are gridded into the GIS master data-base file containing a UTM coordinate space covering the entire project area. Some editing may be necessary where map sheet boundaries join because of photomosaic distortions or other cartographic irregularities encountered in the data integration process.
4. Wetland acreages are calculated by county and reach and displayed on the color video monitor or plotted as hard-copy maps and transparent USGS map overlays.

To date, 4 of 20 counties have been digitized and gridded into the GIS master data-base file. Defining accurate coordinate reference points on the photomosaic map sheets is a critically important step before the digitizing operation. The process for selecting two diagonally opposed reference points begins by locating road intersections or other permanent landmarks that are readily identifiable on the mosaic map sheet and the corresponding 1:62,500-scale USGS quadrangle. Once these two points are located, the USGS quadrangle is placed on the digitizing table and set up. The upper left and lower right map corner coordinates are read from the map in latitude and coordinates, keyed into the computer, and related to a digitizer file by digitizing each corresponding reference point. Next, the two specific mosaic digitizer setup points are digitized off the USGS quadrangle in order to identify those coordinates for later use in digitizing the hydric and nonhydric soil boundaries. An average of six additional control points per quadrangle also are located, and their UTM coordinates are recorded. These points must be selected at landmarks that are visible on the mosaic map sheet. Differences are calculated between common point coordinates from USGS maps and the mosaic map for the six additional control points. An arithmetic average is calculated for the difference and, if necessary, is used

to adjust all the control points, including the two initial points, in the digitized file in the X and Y directions. These adjustments are sometimes made to get a better geometric fit of each map sheet data set as it is gridded into the GIS master data base. Immediately after each mosaic digitizer file is gridded, it is displayed and its spatial relation to the surrounding hydric and nonhydric soils is carefully examined. Gridding of the individual mosaics into the larger digital data-base file is analogous to fitting very small pieces into a large puzzle. However, the gridding process is mathematically controlled; therefore, any offsets (greater than 40 m) must be corrected by translation. The previously selected control points may be used by shifting the gridded mosaic in relation to the average difference, in northing and easting (UTM) control point locations. This reduces the amount of editing required to fill in small data gaps, and it allows smooth transitions for data overlaps at the edges.

## Conclusions

The application of satellite digital image data and GIS technology is a highly effective technique for rapid and accurate wetlands mapping and analysis, especially for large inaccessible wetland complexes. Satellite data resources as a national asset are grossly underused for inventorying wetlands and monitoring changes over time. GIS capabilities offer tremendous advantages for quantitative analysis and visualization of spatial relation that are so important to regional wetlands analyses. This ability to investigate spatial relations challenges scientists to exploit analytical modeling techniques for experimenting with new concepts that will increase the scientific knowledge of wetland processes. The national goal of no net loss in wetlands provides the impetus to apply these advanced technologies routinely and effectively in meeting or exceeding this objective.

## Acknowledgments

Funding for the Mallard Wintering Habitat Study was provided by the U.S. Fish and Wildlife Service's National Wetlands Research Center. Our work was assigned and coordinated with J. R. Nassar and M. W. Brown of the National Wetlands Research Center. Their cooperation and excellent technical support throughout the study

was greatly appreciated. M. R. Graves, WES-EL, was responsible for the Landsat image analysis, development of statistical habitat data, and production of high-resolution color maps.

The Yazoo River Basin Wetlands Mapping Task was funded by the U.S. Army Corps of Engineers, Vicksburg District. This work was conducted under the guidance of K. D. Parrish, the project manager of the upper Yazoo River Basin Project. E. J. Clairain, Jr., WES-EL's research team leader, and his staff were responsible for delineating wetland boundaries on maps. J. Tingle of WES-EL was responsible for quality control of map and mosaic preparation to ensure accuracy and compliance with cartographic standards for digitizing. J. S. Hutto, also of WES-EL, was responsible for generating a composite of all digitized maps into a single geographic data base; she also was the coordinator of all computer-based operations required to produce the final product. J. K. Stoll of WES-EL was responsible for overall

technical coordination and supervision of work conducted in both studies.

## References

- Allen, A. W. 1986. Habitat Suitability Index models: mallard (winter habitat, lower Mississippi Valley). U.S. Fish Wildl. Serv., Biol. Rep. 82(10). 37 pp.
- National Aeronautics and Space Administration. 1989. ELAS, Science and Technology Laboratory Applications Software, programmer reference, Vol. I, user manuals Vol. II and III. Report 183. John C. Stennis Space Center, Miss.
- Swain, P. H. and R. C. King. 1973. Two effective feature selection criteria for multispectral remote sensing. Pages 536-540 in *Proceedings of the first international joint conference on pattern recognition*, IEEE. Cat. No. 73 CHO 82 1-9 C. Piscataway, N. J.
- U.S. Geological Survey. 1982. Index to Landsat worldwide reference systems (WRS) Landsat 1,2,3, and 4, Sheet 9. National Oceanic and Atmospheric Administration, USGS-EROS Data Center, Sioux Falls, S. Dak.

# The Digital Wetlands Data Base for the U.S. Great Lakes Shoreline

by

Michael Scieszka

*Land and Water Management Division  
Michigan Department of Natural Resources  
Stevens T. Mason Building  
P.O. Box 30028  
Lansing, Michigan 48909*

**ABSTRACT.**—Michigan has mapped and digitized a detailed land cover and land use inventory. The program processes the land cover and land use files into various theme maps, including a set of wetland maps. The wetlands map set is used to implement inventory and public information requirements of the State's wetland protection act. The data collection methodology and digital processing environment are being used by the International Joint Commission to map the remainder of the United States' shoreline. I present an overview of the Michigan Resource Inventory Program, how the data were collected, and how to access the data.

The Michigan Resource Inventory Act (1979 PA 204) authorized the Michigan Department of Natural Resources (DNR) to conduct a statewide land cover and land use inventory. The land cover and land use inventory mapped seven main categories: urban land, agricultural land, openland, forestland, water, wetlands, and barrens. This act required DNR to digitize the inventory and to distribute the data in a format that maximizes its use in local planning and zoning. During the same legislative session, Michigan adopted the Goemaere-Anderson Wetland Protection Act (1979 PA 203), which required DNR to provide for the preservation, management, protection, and use of wetlands. PA 203 also required DNR to make a wetland inventory of the State, file it with local governments, and use the inventory data as one of the identifiers of wetlands protected under the statute and administrative rules. The land cover and land use inventory required through PA 204 is being used to meet wetland inventory requirements of PA 203.

The International Joint Commission (IJC), through its Great Lakes Water Level Reference of 1986 (U.S. State Department and Canadian Ministry of External Affairs 1986), identified the need

for a land cover and land use data base for the Great Lakes shoreline. The DNR, in close cooperation with the U.S. Army Corps of Engineers (COE), was assigned the authority to acquire aerial photography for the shoreline, interpret land cover and land use data, digitize the maps, and deliver various data sets for IJC use. The IJC intends to use this data to quantify the effects of various shoreline and water level management scenarios it is considering recommending to the governments within the Great Lakes basin.

## Project Scope and Inventory Methods

The land cover and land use inventory is a component of the Michigan Resource Inventory Program (MRIP) created by PA 204. This program:

- manages and distributes the results of a statewide 1:24,000 color-infrared aerial photography flight made in 1978-79;
- manages and distributes the results of a 1986-87 1:15,840 black and white infrared reflight of the northern two-thirds of Michigan, and a 1:24,000 black and white

panchromatic flight from 1988, which covered the remainder of the state;

- operates the Michigan Resource Information System (MIRIS), which is the umbrella for geographic information system (GIS) processing in Michigan. MIRIS contains a digital base map for the State, the land cover and land use inventory, and, in selected areas, soils data, prime lands information, and other thematic overlays (see Appendix A, B, C, and D);
- provides mapping and GIS services to the Great Lakes research community through the Great Lakes Information System. The geographic focus of these products is along the shoreline and into the Great Lakes, where DNR is encoding such information as fish spawning sites, bathymetry, bottom sediments, sensitive shoreline features, and wetlands;
- implements a statewide groundwater data base that verifies public and private water well locations and digitizes the verified location along with the water well log to create a data-base record containing such information as the well's static water level, geological formation encountered, and depth; and
- provides contractual services to public and private organizations in need of mapping and GIS services.

The land cover and land use inventory, which was completed between 1981–86, is an important component of all the activities and services provided by the Michigan Resource Inventory Program. To complete this inventory in an orderly and consistent manner, the Michigan Resource Inventory Program established standards, a data collection methodology, a classification system, and training and quality-control procedures.

The land cover and land use inventory used 1978–79 aerial photography. The aeriels are at a scale of 1 inch to 2,000 feet (1:24,000) color-infrared photography. The photography mission was flown between 1 June and 30 September to ensure maximum leaf-on condition of trees. Sixty percent overlap was shot for stereo viewing.

The Michigan Resource Inventory Program adopted a land cover and land use classification system that was designed to make the best use of information from our aerial photography. The program started with the system by Anderson (1972), and expanded it to a third level. About 60 land

cover and land use classifications have been mapped. The minimum-size mapping unit is 1.5 to 5 acres. Our system is hierarchical to resolve questions of double or multiple category classifications. The system allows for further classification refinements to enable those users with specific needs to inventory smaller areas with greater detail and exactness.

To assist the photointerpreters, the inventory program contracted with the Michigan State University Center for Remote Sensing to develop a report entitled *A Photo Interpretation Key to Michigan Land Cover/Use*. This report lists each category to be mapped and provides the definition and interpretive characteristics, such as tone and color, texture, pattern, and shape. Stereo appearance and commonly associated land cover and land use activities were also presented when applicable. An example of this report follows in a section on Emergent Wetlands.

#### Description:

These are areas dominated (30 percent or more cover) by erect, rooted herbaceous hydrophytic plants which are growing out of standing water or waterlogged soils. Typical emergent plants are cattails, bulrushes, rushes, reed grass, bur reed, arrow arum, arrowhead, pickerelweed and sedges.

Marsh areas containing emergent types of aquatic plants can be differentiated from aquatic beds and open water by the magenta hues indicative of denser vegetative cover and by a coarser texture. Separating emergent marshes from shrub swamp usually poses little problem because of differences in texture and pattern, and when viewed stereoscopically, height.

Some emergent types have very distinctive signature characteristics. For example, hybrid cattail (*Typha glauca*), when canopy is homogenous and completely pure, is a bright green hue on CIR photography. A midseason shift from crimson or magenta to green for non-hybrid cattails indicates a decrease in IR reflectance associated with dehydration of mesophyll degeneration accompanying early senescence.

Muskrat houses may be detectable in emergent wetlands as small, distinctive white dots. Some may be ringed by a narrow dark band of water. Since cattails and

bulrushes are the principal vegetation comprising muskrat habitats, the photo interpreter can be certain that one or both plants are present.

Reed grass varies in color from greens to reds to pinks, depending indirectly upon water quality and soil moisture. However, it has a characteristically smooth, velvety texture due to lack of leaf bending and large distinct heads. It is often found in disturbance areas (e.g., dredge spoil deposits).

**Interpretive Characteristics:**

**Color:** Red, deep red-brown, blue green, dull green or mottled white patches of bleached stalks (cattail, bur reed), medium red-brown, dark gray red-brown, browns, olive drabs, dark greens (bulrush, rush), strong pink, purplish pink (pigweed, smartweed), pinks (sedges), light pink, gray pink, gray blue gray, gray blue (grasses), brilliant green blue, dark green blue, white (dead vegetation).

**Texture:** Normally medium but may be smoother or fine if stands are pure; emergents may have a slightly granular texture.

**Shape:** Irregular.

**Pattern:** May be concentric or banded around lake.

**Site:** Occurs in depressions in moraine, till plain and outwash and frequently borders open water in such depressions, shallow shoreline areas of lakes.

With the aerials and classification system, the photointerpreters prepared the land cover and land use inventory through relatively standard procedures. Clear sheets of acetate were placed over a photo being viewed under a stereoscope. Homogenous land cover and land use polygons were delineated, interpreted, and coded. Supplementary source materials, such as older inventories, soils data, and topographic maps, were used when available. The acetate overlays were transferred to a stable mylar overlay registered to a screened mylar of the U.S. Geological Survey topographic base map. During this transfer, photo distortion was corrected by "rubber sheeting" the acetate overlay to roads, property lines, and woodlot features on the topographic base. The final cor-

rected overlay and the base were reviewed and corrected by the inventory program's chief cartographer before digitization. In all, more than 1,100 land cover and land use overlays were prepared between 1981 and 1986. On the average, each overlay contained 2,000 distinct land cover and land use polygons. A little more than \$1 million were invested in the photointerpretation effort. The 1978-79 aerial flight cost nearly \$350,000.

The same basic procedure is being used for IJC work, although we did add one substantial wetland category called Coastal Submergents, which are defined as areas contiguous to the shorelines of the Great Lakes where rooted submerged aquatic plants are dominant.

## Description of Mapped and Digital Products

The land cover and land use inventory overlay was either hand-digitized at the Michigan Resource Inventory Program or subcontracted to digitizing service bureaus. The digital data are structured as line strings/text file. Each boundary line between different land cover and land use areas was digitized, and a single text per polygon area was inserted. The internal coordinate system used for georeferencing is the Michigan State Plane Coordinate System for the State of Michigan files and is in latitude and longitude internal coordinates for IJC work.

After the data were encoded, they were available in four basic forms:

- line/text file, which can be plotted in scales ranging from 1 inch to 1,320 feet to 1 inch to 2,000 feet. This product will contain all land cover and land use including wetlands;
- digital version of the line/text file can be produced in Intergraph Design File Format, Standard Interchange Format, or Data Exchange Format;
- an acreage report, which quantifies land cover and land use by governmental units, is published; and
- a patterned theme map, which selectively displays various land cover and land use polygons.

Appendix E shows a line/text example and a wetland theme map example. The theme maps are one of our most popular products. To generate a theme map, we process the line/text file through a series of routines built with Intergraph's Spatial

Editor/Spatial Analyst program. The routines search the line/text files, pull out the polygon wanted, and pattern the resultant file to highlight the theme.

To generate a wetland theme map, the following categories are searched for and extracted. (Note: The following definitions are from the classification system adopted for the Michigan Resource Inventory Program; this system is the one being used for IJC effort.)

#### *414 Lowland Hardwoods*

Ash, elm, and soft maple, along with cottonwood, balm of Gilead, and other lowland hardwoods.

#### *423 Lowland Conifers*

Lowland species category, including areas of predominantly cedar, tamarack, black and white spruce, and balsam fir stands.

#### *51 Streams and Waterways*

This category includes rivers, streams, creeks, canals, drains, and other linear bodies of water. Where the water course is interrupted by a control structure that creates an impoundment, the impounded area should be classified as a reservoir. The boundary between streams and lakes, or reservoirs, is the straight line across the mouth of the stream.

#### *52 Lakes*

Lakes are nonlinear water bodies, excluding reservoirs. A water body should be classified as a lake if a structure has been installed primarily to regulate or stabilize lake levels without significantly increasing the water area. The delineation of a lake will be based on the areal extent of water at the time the data are collected.

#### *53 Reservoirs*

Reservoirs are artificial impoundments of water, whether for irrigation, flood control, municipal or industrial water supply, hydroelectric power, or recreation.

#### *611 Wooded Wetland*

This class applies to wetlands dominated by trees more than 6.1 m tall. The soil surface is seasonally flooded with up to 30.5 cm of water. Several levels of vegetation are usually present, including trees, shrubs, and herbaceous plants. Some of the predominant tree species include ash, elm, red maple, cedar, black spruce, tamarack, and balsam fir.

#### *612 Shrub/Scrub Wetland*

This class applies to wetlands dominated by woody vegetation less than 6 m tall. Vegetation

includes shrub and small or stunted trees. This class includes both stable shrub wetlands and areas in a successional stage leading to wooded wetlands. Some of the predominant species include alder, dogwood, sweetgale, leatherleaf, willow-buttonbush associations, and water willow. Any standing dead trees, shrubs, and stumps should be in the 612 category.

#### *621 Aquatic Bed Wetland*

The 621 category is used to map an area that generally has 30% or more vegetation cover of submerged, floating-leaved or floating plants, and is less than 2 m deep. Typical plant species are yellow water lily, duckweed, and pond weeds.

#### *622 Emergent Wetlands*

These are wetland areas dominated (30% or more cover) by erect, rooted, herbaceous hydrophytic plants, which are present for most of the growing season in most years. These areas are usually dominated by perennial plants, although annuals are often present too. Typical species include cattail, bulrush, sedges, reeds, wild rice, pickerelweed, arrowhead, and so forth.

#### *623 Flats*

These are level or nearly level deposits of unconsolidated sand, mud, or organic sediments, with less than 75% aerial coverage of stones, boulders, or bedrock, and less than 30% aerial coverage of vegetation other than pioneering plants.

## Map Product Availability

The Michigan Resource Inventory Program maps and digital data are available through three methods. First, the program has all files in a readily retrievable form. Appendix F is a schematic of the overall system used to digitize, store, process, and output digital data for Michigan. People can call or write to acquire either plots or digital versions of the inventory program's data.<sup>1</sup>

A second method of obtaining maps and digital data is through the "local holders of map sets." When a county's land cover and land use base map and other data sets are processed, that county

<sup>1</sup> A nominal fee is charged. For instance, if a user wanted a single quadrangle of land cover data, plots would cost \$45 and digital \$60. Base maps for the same area would cost \$35 for a plot and would cost \$50 for digital. The Michigan Resource Inventory Program is authorized to use these fees during the fiscal year to cover operating and staff costs.

receives a set of mylars or a digital version of these data. This is required through PA 204, and it follows the legislative intent of the program, which is to assist local governments in making land use decisions by providing them with accurate land resource data. Counties are also informed that the wetlands data is to be considered as a preliminary wetland inventory of their area as required by PA 203.

Land cover and land use data can also be obtained through COE. The COE is establishing GIS processing capabilities in its Detroit District office. As part of our working relationship with COE, Michigan's shoreline land cover and land use files, and the remainder of the U.S. shoreline files we are developing for IJC, will be delivered to the COE.

### **Future Activities**

Our staff will be focusing its future wetlands activities in two areas. Since 1985, the Michigan

Resource Inventory Program and the U.S. Department of Agriculture's Soil Conservation Service of Michigan have jointly worked on encoding modern soil surveys. We will continue providing the ability to identify hydric soils in relation to wetlands and other vegetation. The Michigan Inventory Resource Program is also working on a proposal to integrate SPOT Image Corporation satellite imagery with existing land cover and land use files to identify where land cover and land use changes are occurring. This imagery, along with recent reflights, gives us the ability to update land cover and land use date for Michigan.

### **References**

- U.S. State Department and the Canadian Ministry of External Affairs. 1986. Great Lakes water level reference of 1986. U.S. State Department, Washington, D.C., and the Canadian Ministry of External Affairs, Ottawa, Canada. 10 pp.









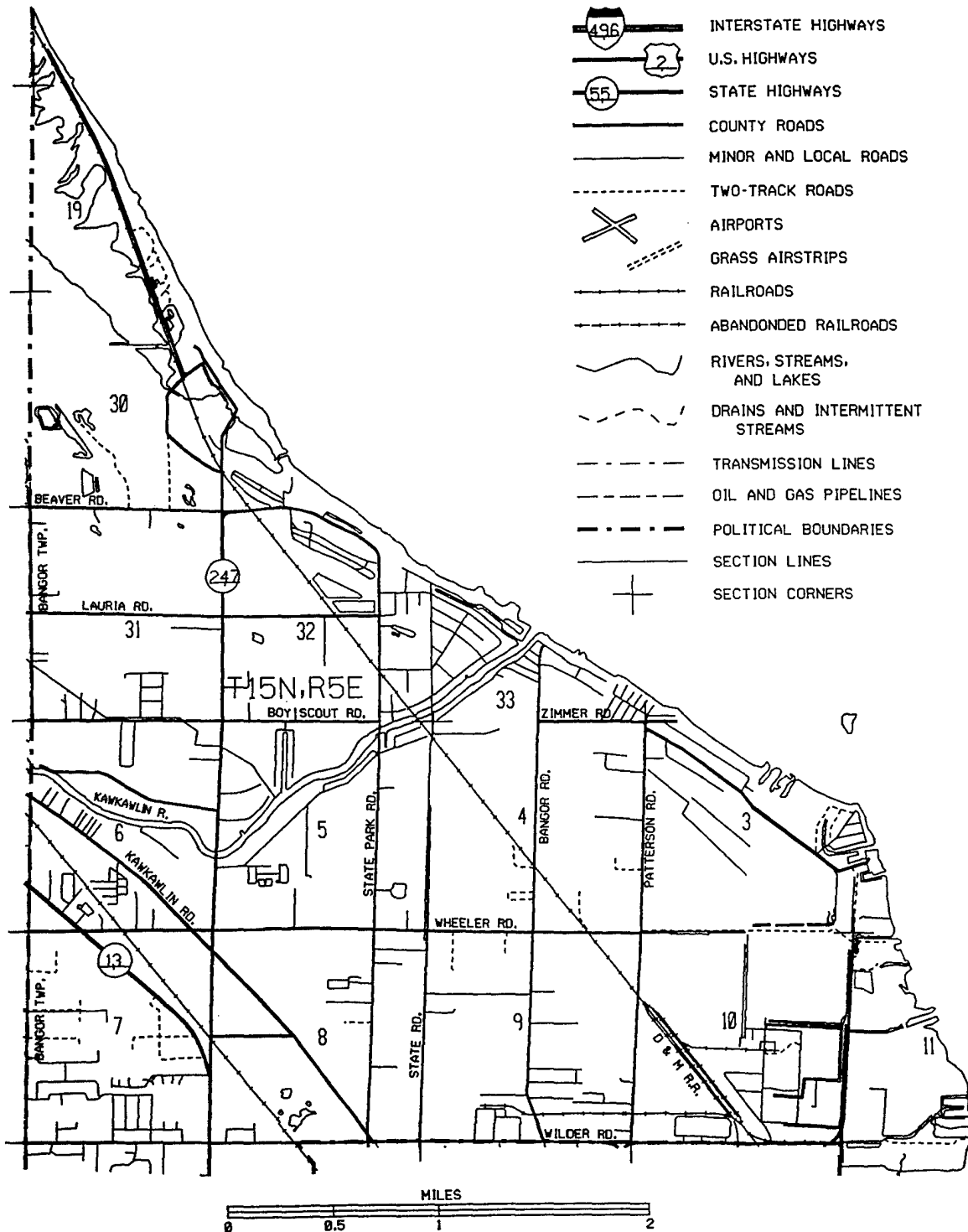



SOURCE: USGS TOPOGRAPHIC BASE MAP SERIES

# Appendix C. Michigan Resource Information System (MIRIS) and Great Lakes Information System (GLIS) Summary Status of Digital Map Products

CHART I

MICHIGAN RESOURCE INFORMATION SYSTEM   
 GREAT LAKES INFORMATION SYSTEM   
 SUMMARY STATUS OF DIGITAL MAP PRODUCTS

COUNTY	MIRIS MAP SETS										GLIS MAP SETS					
	BASE MAP	CURRENT USE	PUBLIC LANDS	PRIME AGRICULTURAL LANDS	WELLS - OIL & GAS	NATURAL FOREST LANDS	SOILS	GROUNDWATER DATA	FLOODPRONE AREAS	EROSION AREAS	ENVIRONMENTAL AREAS	WUVE SPECIAL AREAS				
ALCONA	X	O	O	O	O											ALCONA
ALGER	O	O	O													ALGER
ALLEGAN				N						O	O	O				ALLEGAN
ALPENA	X	O	O	O	N											ALPENA
ANTRIM	X	O	O													ANTRIM
ARENAC	X	O	O	N												ARENAC
BARAGA	X	O	O													BARAGA
BARRY																
BAY		O	O	N					X	O	O	O				BAY
BENZIE		O	O	N						O	O	O				BENZIE
BERRIEN		O	O	N						O	O	O				BERRIEN
BRANCH				N												
CALHOUN		O	O	N												
CASS	X	O	O	N												
CHARLEVOIX	X	O	O							O	O	O				CHARLEVOIX
CHEBOYGAN		O	O													CHEBOYGAN
CHIPPEWA		O	O							O	O	O				CHIPPEWA
CLARE	X	O	O	N												
CLINTON	X	O	O	O	N											
CRAWFORD	X	O	O	O	O	O	O	O								
DELTA	X	O	O	O	O	O	O	O								DELTA
DICKINSON	X	O	O	O	O	O	O	O								
EATON				N												
EMMET	X	O	O	O						O	O	O				EMMET
GENESEE		O	O	N												
GLADWIN	X	O	O	N												
GOGEBIC	X	O	O													GOGEBIC
GRAND TRAVERSE	X	O	O	O						O						GRAND TRAVERSE
GRATIOT				N												
HILLSDALE	X	O	O													
HOUGHTON	X	O	O													HOUGHTON
HURON		O	O	N					X	O	O	O				HURON
INGHAM		O	O	N												
IONIA		O	O													
IOSCO		O	O	N					X	O	O					IOSCO
IRON		O	O													
ISABELLA	X	O	O	N												
JACKSON	X	O	O													
KALAMAZOO		O	O	N												
KALKASKA		O	O													
KENT	X	O	O	N	O	O										

- O COMPLETE
- ∅ PARTIAL OR IN PRODUCTION
- N NOT APPLICABLE
- X MAPS DISTRIBUTED TO COUNTIES

# Appendix D. Michigan Resource Information System (MIRIS) and Great Lakes Information System (GLIS) Summary Status of Digital Map Products

CHART 2

MICHIGAN RESOURCE INFORMATION SYSTEM

GREAT LAKES INFORMATION SYSTEM

SUMMARY STATUS OF DIGITAL MAP PRODUCTS.

COUNTY	MIRIS MAP SETS										GLIS MAP SETS				
	BASE MAP	CURRENT USE	PUBLIC LANDS	PRIME AGRICULTURAL LANDS	PRIME FOREST LANDS	WELLS - OIL & GAS	NATURAL FEATURES	SOILS	GROUNDWATER DATA	307 SITES	FLOODPRONE AREAS	EROSION AREAS	ENVIRONMENTAL AREAS	DUPLICATE AREAS	SPECIAL AREAS
KEWEENAW	○	○							○				○		
LAKE					N										
LAPEER	⊗														
LEELANAU											○				
LENAWEE															
LIVINGSTON	⊗				N										
LUCE														○	
MACKINAC									○					○	
MACOMB	⊗				N						⊗				
MANISTEE	⊗											○			
MARQUETTE	⊗														
MASON					N										
MECOSTA					N										
MENOMINEE									○						
MIDLAND	⊗				N										
MISSAUKEE															
MONROE	⊗				N										
MONTCALM					N										
MONTMORENCY	⊗														
MUSKEGON					N										
NEWAYGO															
OAKLAND	⊗				N										
OCEANA															
OGEMAW					N										
ONTONAGON									○						
OSCEOLA					N										
OSCODA															
OTSEGO	⊗														
OTTAWA					N										
PRESQUE ISLE															
ROSCOMMON															
SAGINAW					N										
SANILAC					N										
SCHOOLCRAFT														○	
SHIAWASSEE					N										
ST. CLAIR	⊗				N										
ST. JOSEPH					N										
TUSCOLA					N										
VAN BUREN	⊗				N										
WASHTENAW															
WAYNE	⊗				N										
WEXFORD															

- COMPLETE
- ◐ PARTIAL OR IN PRODUCTION
- N NOT APPLICABLE
- ⊗ MAPS DISTRIBUTED TO COUNTIES

# Appendix E. Example of a Patterned Map and Example of a Line and Text Map of Bangor Township, Bay County

MAP 3

## EXAMPLE PATTERNED MAP

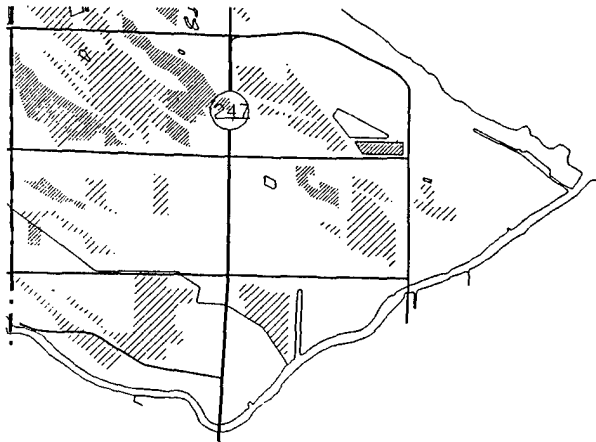

PATTERNED MAPS ARE PRODUCED BY SELECTIVELY RETRIEVING FROM LINE & TEXT FILES SPECIFIC THEMES. THE EXAMPLE MAP IS A WETLAND THEME MAP PLOTTED ON THE BASE FEATURES. OTHER THEMES INCLUDE URBAN, AGRICULTURE AND, OPEN, FORESTLAND, AND EXTRACTIVE.

**LEGEND**

- ▨ LOWLAND HARDWOOD (414,611)
- ▩ SHRUB WETLAND (612)
- ▧ EMERGENT WETLAND (622)
- ▦ AQUATIC BED (623)

## EXAMPLE LINE & TEXT MAP

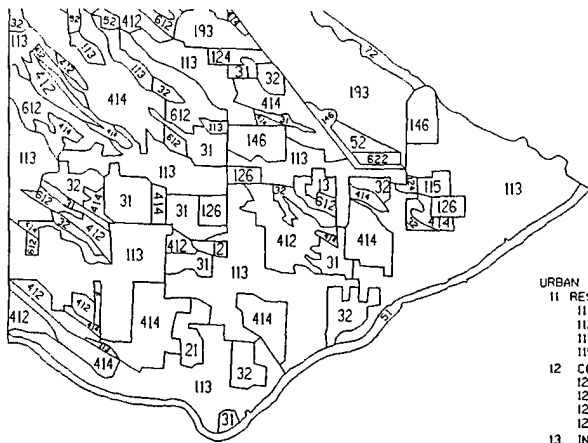

LINE & TEXT MAPS REPRODUCE THE ORIGINAL PHOTO INTERPRETATION. THE MAPS CONTAIN THE CLASSIFICATIONS LISTED ON THE LEGEND BELOW.

**CURRENT LAND COVER/USE LEGEND**

- |  |  |
|--|--|
| <p><b>URBAN</b></p> <ul style="list-style-type: none"> <li>11 RESIDENTIAL                     <ul style="list-style-type: none"> <li>111 MULTI-FAMILY,HIGH RISE</li> <li>112 MULTI-FAMILY,LOW RISE</li> <li>113 SINGLE FAMILY,DUPLX</li> <li>115 MOBILE HOME PARK</li> </ul> </li> <li>12 COMMERCIAL, SERVICES, INSTITUTIONAL                     <ul style="list-style-type: none"> <li>121 PRIMARY/CENTRAL BUSINESS DISTRICT</li> <li>122 SHOPPING CENTER/MALL</li> <li>124 SECONDARY BUSINESS/STRIP COMMERCIAL</li> <li>126 INSTITUTIONAL</li> </ul> </li> <li>13 INDUSTRIAL                     <ul style="list-style-type: none"> <li>138 INDUSTRIAL PARK</li> </ul> </li> <li>14 TRANSPORTATION, COMMUNICATIONS, UTILITIES                     <ul style="list-style-type: none"> <li>141 AIR TRANSPORTATION</li> <li>142 RAIL TRANSPORTATION</li> <li>143 WATER TRANSPORTATION</li> <li>144 ROAD TRANSPORTATION</li> <li>145 COMMUNICATIONS</li> <li>146 UTILITIES</li> </ul> </li> <li>17 EXTRACTIVE                     <ul style="list-style-type: none"> <li>171 OPEN PIT</li> <li>172 UNDERGROUND</li> <li>173 WELLS</li> </ul> </li> <li>19 OPEN LAND, OTHER                     <ul style="list-style-type: none"> <li>193 OUTDOOR RECREATION</li> <li>194 CEMETERIES</li> </ul> </li> <li>AGRICULTURE                     <ul style="list-style-type: none"> <li>21 CROPLAND</li> <li>22 ORCHARDS</li> <li>23 CONFINED FEEDING</li> <li>24 PERMANENT PASTURE</li> <li>29 OTHER</li> </ul> </li> </ul> | <ul style="list-style-type: none"> <li>NONFORESTED                     <ul style="list-style-type: none"> <li>31 HERBACEOUS</li> <li>32 SHRUB</li> </ul> </li> <li>FORESTED                     <ul style="list-style-type: none"> <li>41 DECIDUOUS                             <ul style="list-style-type: none"> <li>411 NORTHERN HARDWOOD</li> <li>412 CENTRAL HARDWOOD</li> <li>413 ASPEN/WHITE BIRCH</li> <li>414 LOWLAND HARDWOOD</li> </ul> </li> <li>42 CONIFEROUS                             <ul style="list-style-type: none"> <li>421 PINE</li> <li>422 OTHER UPLAND CONIFER</li> <li>423 LOWLAND CONIFER</li> <li>429 CHRISTMAS TREE</li> </ul> </li> </ul> </li> <li>WATER                     <ul style="list-style-type: none"> <li>51 STREAM</li> <li>52 LAKE</li> <li>53 RESERVOIR</li> <li>54 GREAT LAKES</li> </ul> </li> <li>WETLANDS                     <ul style="list-style-type: none"> <li>61 FORESTED                             <ul style="list-style-type: none"> <li>611 WOODED</li> <li>612 SHRUB, SCRUB</li> </ul> </li> <li>62 NONFORESTED                             <ul style="list-style-type: none"> <li>621 AQUATIC BED</li> <li>622 EMERGENT</li> <li>623 FLATS</li> </ul> </li> </ul> </li> <li>BARREN                     <ul style="list-style-type: none"> <li>72 BEACH, RIVERBANK</li> <li>73 SAND DUNE</li> <li>74 EXPOSED ROCK</li> </ul> </li> </ul> |
|--|--|

EXAMPLES ARE FROM A SMALL PART OF BANGOR TOWNSHIP, BAY COUNTY



## Appendix F. Michigan Resource Information System (MIRIS) Configuration

DIAGRAM 3

MIRIS SYSTEM CONFIGURATION

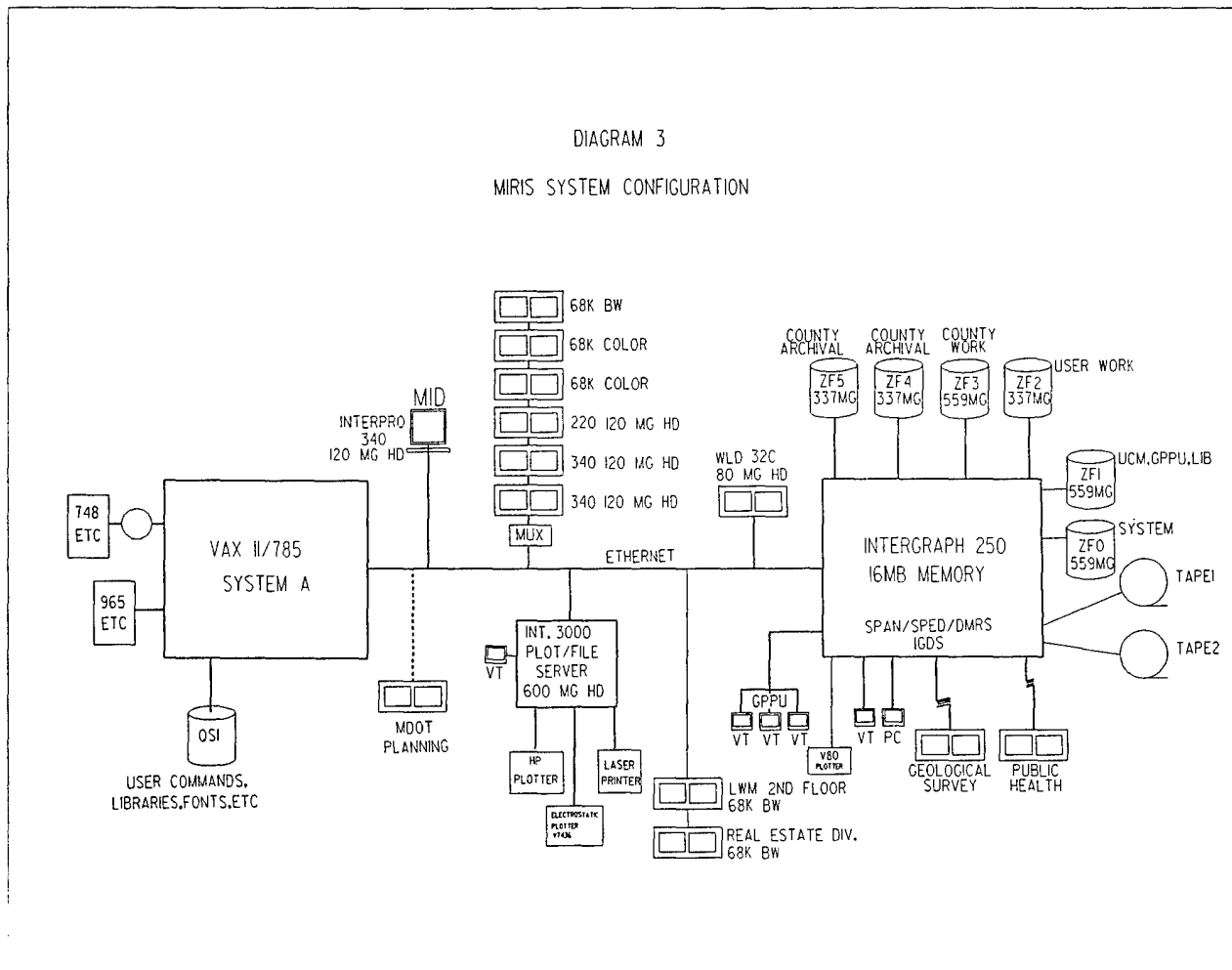

## Appendix. Habitat Loss and Modification Working Group

---

Co-chairs:           John D. Buffington  
                          Region 8, Research and Development  
                          U.S. Fish and Wildlife Service  
                          U.S. Department of the Interior  
                          1849 C Street, N.W., Room 3245  
                          Washington, D.C. 20240

                          Ford A. Cross  
                          Beaufort Laboratory, Southeast Fisheries Center  
                          National Marine Fisheries Service  
                          National Oceanic and Atmospheric Administration  
                          Beaufort, North Carolina 28516-9722

Coordinator:        Sari J. Kiraly  
                          National Ocean Pollution Program Office, CS/OP  
                          Office of the Chief Scientist  
                          National Oceanic and Atmospheric Administration  
                          Universal Building, Room 625  
                          1825 Connecticut Avenue, N.W.  
                          Washington, D.C. 20235

Franklin S. Baxter  
National Mapping Division  
U.S. Geological Survey  
590 National Center  
Reston, Virginia 22097

John W. Bellinger  
Office of Environmental Policy, CECW-RE  
U.S. Army Corps of Engineers  
20 Massachusetts Avenue, N.W.  
Washington, D.C. 20314-1000

Virginia Carter  
Water Resources Division  
U.S. Geological Service  
430 National Center  
Reston, Virginia 22092

Don W. Field  
Ocean Assessments Division  
National Ocean Service, N/OMA31  
National Oceanic and Atmospheric Administration  
6001 Executive Boulevard, Room 305  
Rockville, Maryland 20852



Robert Middleton  
Branch of Environmental Operations  
Mineral Management Service  
U.S. Department of the Interior  
Mail Stop 644  
381 Elden Street  
Herndon, Virginia 22070

Dorene Robb  
Office of Wetlands Protection  
U.S. Environmental Protection Agency  
A-104F  
401 M. Street, S.W.  
Washington, D.C. 20460

Michael Slimak and Steve Cordle  
Office of Environmental Processes and  
Effects Research  
U.S. Environmental Protection Agency  
RD-682  
West Tower, Room 609  
401 M. Street, S.W.  
Washington D.C. 20460

John Sutherland  
Office of Oceanic Research Programs  
National Sea Grant College Program  
Oceanic and Atmospheric Research  
National Oceanic and Atmospheric Administration  
1335 East West Highway, Room 5226  
Silver Spring, Maryland 20910

Billy M. Teels  
Soil Conservation Service  
U.S. Department of Agriculture  
South Agriculture Building, Room 6144  
P.O. Box 2890  
Washington D.C. 20013

Bill O. Wilen  
National Wetlands Inventory  
U.S. Fish and Wildlife Service  
400-ARLSQ  
U.S. Department of the Interior  
18th and C Street, N.W.  
Washington D.C. 20240

Kiraly, Sari J., Ford A. Cross, and John D. Buffington. 1990. **Federal Coastal Wetland Mapping Programs**. U.S. Fish Wildl. Serv., *Biol. Rep.* 90(18). 174 pp.

A workshop was held in December 1989 to examine the Federal effort in mapping the Nation's coastal wetlands. The workshop took place at the U.S. Fish and Wildlife Service's National Wetlands Research Center in Slidell, Louisiana. The papers presented at the workshop and recommendations for improving the Federal effort are contained in this report.

**Key words:** Coastal wetlands mapping, mapping programs, wetlands.

Kiraly, Sari J., Ford A. Cross, and John D. Buffington. 1990. **Federal Coastal Wetland Mapping Programs**. U.S. Fish Wildl. Serv., *Biol. Rep.* 90(18). 174 pp.

A workshop was held in December 1989 to examine the Federal effort in mapping the Nation's coastal wetlands. The workshop took place at the U.S. Fish and Wildlife Service's National Wetlands Research Center in Slidell, Louisiana. The papers presented at the workshop and recommendations for improving the Federal effort are contained in this report.

**Key words:** Coastal wetlands mapping, mapping programs, wetlands.

Kiraly, Sari J., Ford A. Cross, and John D. Buffington. 1990. **Federal Coastal Wetland Mapping Programs**. U.S. Fish Wildl. Serv., *Biol. Rep.* 90(18). 174 pp.

A workshop was held in December 1989 to examine the Federal effort in mapping the Nation's coastal wetlands. The workshop took place at the U.S. Fish and Wildlife Service's National Wetlands Research Center in Slidell, Louisiana. The papers presented at the workshop and recommendations for improving the Federal effort are contained in this report.

**Key words:** Coastal wetlands mapping, mapping programs, wetlands.

Kiraly, Sari J., Ford A. Cross, and John D. Buffington. 1990. **Federal Coastal Wetland Mapping Programs**. U.S. Fish Wildl. Serv., *Biol. Rep.* 90(18). 174 pp.

A workshop was held in December 1989 to examine the Federal effort in mapping the Nation's coastal wetlands. The workshop took place at the U.S. Fish and Wildlife Service's National Wetlands Research Center in Slidell, Louisiana. The papers presented at the workshop and recommendations for improving the Federal effort are contained in this report.

**Key words:** Coastal wetlands mapping, mapping programs, wetlands.

NOTE: The mention of trade names does not constitute endorsement or recommendation for use by the Federal Government.

# TAKE PRIDE

*in America*



U.S. DEPARTMENT OF THE INTERIOR  
FISH AND WILDLIFE SERVICE



As the Nation's principal conservation agency, the Department of the Interior has responsibility for most of our nationally owned public lands and natural resources. This includes fostering the wisest use of our land and water resources, protecting our fish and wildlife, and providing for the enjoyment of life through outdoor recreation. The Department assesses our energy and mineral resources and works to assure that their development is in the best interests of all our people. The Department also has a major responsibility for American Indian reservation communities and for people who live in island territories under U. S. administration.