



ARLIS

3 3755 001 07037 4

---

BIOLOGICAL REPORT 82(10.102)  
AUGUST 1985

# **HABITAT SUITABILITY INDEX MODELS: GREATER PRAIRIE-CHICKEN (MULTIPLE LEVELS OF RESOLUTION)**

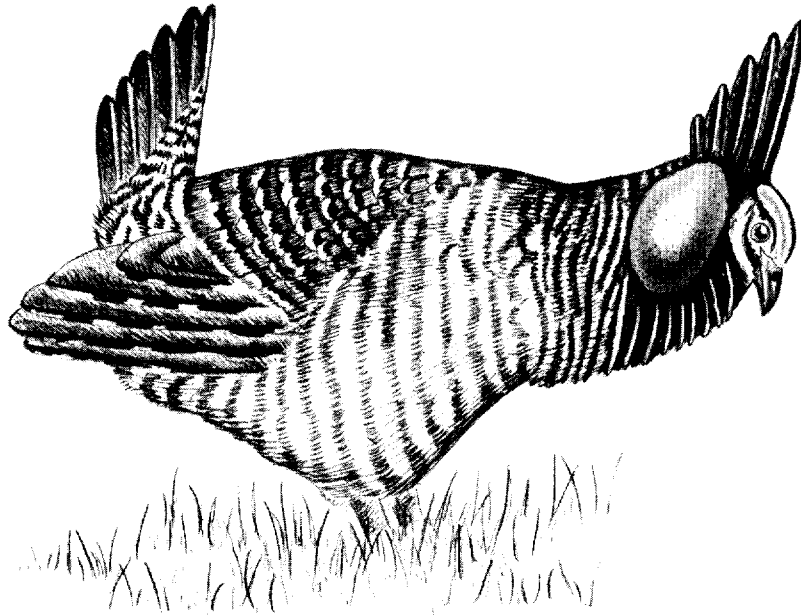

Fish and Wildlife Service

---

**U.S. Department of the Interior**

This is one of the first reports to be published in the new "Biological Report" series. This technical report series, published by the Research and Development branch of the U.S. Fish and Wildlife Service, replaces the "FWS/OBS" series published from 1976 to September 1984. The Biological Report series is designed for the rapid publication of reports with an application orientation, and it continues the focus of the FWS/OBS series on resource management issues and fish and wildlife needs.

MODEL EVALUATION FORM

Habitat models are designed for a wide variety of planning applications where habitat information is an important consideration in the decision process. However, it is impossible to develop a model that performs equally well in all situations. Assistance from users and researchers is an important part of the model improvement process. Each model is published individually to facilitate updating and reprinting as new information becomes available. User feedback on model performance will assist in improving habitat models for future applications. Please complete this form following application or review of the model. Feel free to include additional information that may be of use to either a model developer or model user. We also would appreciate information on model testing, modification, and application, as well as copies of modified models or test results. Please return this form to:

Habitat Evaluation Procedures Group  
U.S. Fish and Wildlife Service  
2627 Redwing Road, Creekside One  
Fort Collins, CO 80526-2899

Thank you for your assistance.

Species \_\_\_\_\_ Geographic  
Location \_\_\_\_\_

Habitat or Cover Type(s) \_\_\_\_\_

Type of Application: Impact Analysis \_\_\_\_ Management Action Analysis \_\_\_\_  
Baseline \_\_\_\_ Other \_\_\_\_\_

Variables Measured or Evaluated \_\_\_\_\_  
\_\_\_\_\_  
\_\_\_\_\_

Was the species information useful and accurate? Yes \_\_\_\_ No \_\_\_\_

If not, what corrections or improvements are needed? \_\_\_\_\_  
\_\_\_\_\_  
\_\_\_\_\_

Were the variables and curves clearly defined and useful? Yes  No

If not, how were or could they be improved? \_\_\_\_\_

\_\_\_\_\_  
\_\_\_\_\_

Were the techniques suggested for collection of field data:

Appropriate? Yes  No

Clearly defined? Yes  No

Easily applied? Yes  No

If not, what other data collection techniques are needed? \_\_\_\_\_

\_\_\_\_\_  
\_\_\_\_\_

Were the model equations logical? Yes  No

Appropriate? Yes  No

How were or could they be improved? \_\_\_\_\_

\_\_\_\_\_  
\_\_\_\_\_

Other suggestions for modification or improvement (attach curves, equations, graphs, or other appropriate information) \_\_\_\_\_

\_\_\_\_\_  
\_\_\_\_\_

Additional references or information that should be included in the model:

\_\_\_\_\_  
\_\_\_\_\_  
\_\_\_\_\_  
\_\_\_\_\_

Model Evaluator or Reviewer \_\_\_\_\_ Date \_\_\_\_\_

Agency \_\_\_\_\_

Address \_\_\_\_\_

\_\_\_\_\_  
\_\_\_\_\_

Telephone Number Comm: \_\_\_\_\_ FTS \_\_\_\_\_

Biological Report 82(10.102)  
August 1985

HABITAT SUITABILITY INDEX MODELS:  
GREATER PRAIRIE-CHICKEN (MULTIPLE LEVELS OF RESOLUTION)

by

Bart L. Prose  
Habitat Evaluation Procedures Group  
Western Energy and Land Use Team  
U.S. Fish and Wildlife Service  
2627 Redwing Road  
Fort Collins, CO 80526-2899

Western Energy and Land Use Team  
Division of Biological Services  
Research and Development  
Fish and Wildlife Service  
U.S. Department of the Interior  
Washington, DC 20240

This report should be cited as:

Prose, B. L. 1985. Habitat suitability index models: Greater prairie-chicken (multiple levels of resolution). U.S. Fish Wildl. Serv. Biol. Rep. 82(10.102). 33 pp.

## PREFACE

This document is part of the Habitat Suitability Index (HSI) Model Series [Biological Report 82(10)] which provides habitat information useful for impact assessment and habitat management. Several types of habitat information are provided. The Habitat Use Information Section is largely constrained to those data that can be used to derive quantitative relationships between key environmental variables and habitat suitability. This information provides the foundation for the HSI model and may be useful in the development of other models more appropriate to specific assessment or evaluation needs.

The HSI Model Section documents the habitat model and includes information pertinent to its application. The model synthesizes the habitat use information into a framework appropriate for field application and is scaled to produce an index value between 0.0 (unsuitable habitat) and 1.0 (optimum habitat). The HSI Model Section includes information about the geographic range and seasonal application of the model, its current verification status, and a list of the model variables with recommended measurement techniques for each variable.

The model is a formalized synthesis of biological and habitat information published in the scientific literature and may include unpublished information reflecting the opinions of identified experts. Habitat information about wildlife species frequently is represented by scattered data sets collected during different seasons and years and from different sites throughout the range of a species. The model presents this broad data base in a formal, logical, and simplified manner. The assumptions necessary for organizing and synthesizing the species-habitat information into the model are discussed. The model should be regarded as a hypothesis of species-habitat relationships and not as a statement of proven cause and effect relationships. The model may have merit in planning wildlife habitat research studies about a species, as well as in providing an estimate of the relative suitability of habitat for that species. User feedback concerning model improvements and other suggestions that may increase the utility and effectiveness of this habitat-based approach to fish and wildlife planning are encouraged. Please send suggestions to:

Habitat Evaluation Procedures Group  
Western Energy and Land Use Team  
U.S. Fish and Wildlife Service  
2627 Redwing Road  
Ft. Collins, CO 80526-2899

## CONTENTS

	<u>Page</u>
PREFACE .....	iii
FIGURES .....	vi
ACKNOWLEDGMENTS .....	vii
INTRODUCTION .....	1
HABITAT USE INFORMATION .....	1
General .....	1
Food .....	1
Water .....	3
Cover .....	3
Reproduction .....	4
Composition and Movements .....	7
Special Considerations .....	7
HABITAT SUITABILITY INDEX (HSI) MODEL .....	7
Model Applicability .....	7
Model Description .....	10
Application of the Model .....	23
SOURCES OF OTHER MODELS .....	30
REFERENCES .....	30



## FIGURES

<u>Number</u>		<u>Page</u>
1	The historic range of the greater prairie-chicken .....	8
2	The relationship between type of crops present and winter food suitability for the greater prairie-chicken .....	11
3	The relationship between fall and winter crop management practices and winter food suitability for the greater prairie-chicken .....	13
4	The relationship between the average visual obstruction reading (VOR) of residual vegetation and nesting cover suitability for the greater prairie-chicken .....	15
5	The relationship between the distance separating cover types providing different life requisites and habitat suitability for the greater prairie-chicken .....	17
6	The relationship between the percent area providing equivalent optimum winter food and winter food suitability for the greater prairie-chicken .....	18
7	The relationship between percent permanent grassland and greater prairie-chicken density .....	19
8	The relationship between percent area providing equivalent optimum nesting cover and nesting cover suitability for the greater prairie-chicken .....	20
9	The relationship of habitat variables, life requisites, cover types, and the HSI for the greater prairie-chicken ....	23
10	Definitions of variables and suggested measurement techniques .....	24
11	Various relationships in this model with the outlined area showing those under consideration at the level of resolution illustrated in example 2 .....	28
12	Various relationships in this model with the outlined area showing those under consideration at the level of resolution illustrated in example 3 .....	29

## ACKNOWLEDGMENTS

The following persons reviewed preliminary drafts of this model: Phillip M. Arnold, Bruce C. Bell, Keith E. Evans, John R. Foster, Arnold D. Kruse, L. Jean O'Neil, Thomas H. Roberts, Thomas E. Toney, Grady W. Towns, James S. Wakeley, and Ronald L. Westemeier. Their comments and suggestions greatly facilitated development of this model, and their time and contributions are gratefully acknowledged.

The greater prairie-chicken illustration on this document's cover was drawn by Jennifer Shoemaker. Word processing was provided by Elizabeth Graf, Carolyn Gulzow, and Dora Ibarra.

## GREATER PRAIRIE-CHICKEN (Tympanuchus cupido pinnatus)

### INTRODUCTION

The practicality of habitat models depends on the user's constraints (e.g., time, budget, available data), and the level of resolution required for given applications. The recommended sampling techniques may be more intensive than the user's constraints allow, or than are necessary to obtain desired outputs. The objective of this document is to present a habitat model for the greater prairie-chicken (Tympanuchus cupido pinnatus), and to demonstrate the model's flexibility in applications involving different levels of data availability and user objectives. The user can place emphasis on the model constituents pertinent to a given level of detail through modifications of sampling techniques.

### HABITAT USE INFORMATION

#### General

The greater prairie-chicken is most characteristic of tall grass prairie, oak savannah, and aspen parkland, but has moved to some extent into the manmade grasslands of the Great Lakes States and southern Ontario (Aldrich 1963). After becoming extirpated from Michigan in 1983 (J. Urbain, Michigan Department of Natural Resources, Lansing; pers. comm.), only about 500,000 greater prairie-chickens remained in 10 States (Johnsgard 1983), down from about 1,086,000 in 12 States in 1968 (Westemeier 1980). In 1983, greater prairie-chickens remained only in the tallgrass prairie States of Illinois, Wisconsin, Minnesota, and Missouri, and in the Great Plains States of Oklahoma, Kansas, Nebraska, South Dakota, North Dakota, and Colorado.

#### Food

Greater prairie-chickens primarily are herbivorous, except during their first few weeks of life when they heavily depend on invertebrates, mainly insects (Evans 1968). The insectivorous diet of young chicks gradually shifts to higher proportions of plant material as they mature (Yeatter 1943). The prairie-chicken's diet largely is determined by availability and therefore varies by season and geographic location (Evans 1968). Prairie-chickens originally depended on wild seeds, leaves, fruits, and insects for food, but are now considerably granivorous due to the introduction of agriculture into their range (Edminster 1954). Mast and buds have become important winter foods in the northern parts of their range.

Succulent leaves and insects generally are abundant in the spring and summer diet (Edminster 1954). Adult prairie-chickens apparently consume more insects than do adults of other grouse species (Evans 1968). Grains become an important food in the fall and are heavily used throughout winter and into spring (Edminster 1954). The use of succulent leaves increases during the spring as they become available. This pattern of seasonal food habits has been documented for greater prairie-chickens in Wisconsin (Schmidt 1936), Illinois (Yeatter 1943), Kansas (Baker 1953; Horak 1971), Oklahoma (Jones 1963), and Missouri (Korschgen 1962; Drobney and Sparrowe 1977; Toney 1980).

The diet of 9 to 10 week old prairie-chickens in southeastern Illinois was 40% insects, 23% fruits, 19% grains, 12% wild seeds, and 6% browse (Yeatter 1943). Short-horned grasshoppers (Acrididae), wheat (Triticum aestivum), dewberry fruit (Rubus villosus), and buttonweed (Diodia teres) seeds were important food items. Insects, mainly leaf beetles (Chrysomelidae), made up 97% of the foods consumed by broods in Oklahoma during their first month of life (Jones 1963).

Adult prairie-chickens in southeastern Illinois consumed 36% wild seeds, 31% fruits, 18% browse, 9% insects, 5% grains, and 0.5% mast, during late June through August (Yeatter 1943). Important food items were buttonweed, dewberry, flowering spurge (Euphorbia corollata), giant ragweed (Ambrosia trifida), and short-horned grasshoppers.

Important spring and summer foods of prairie-chickens in Oklahoma native pasture were goldenrod (Solidago spp.), prairie rosegentian (Sabatia campestris), and grass (Gramineae) (Jones 1963). Korean lespedeza (Lespedeza stipulacea) was the predominant spring and summer food of birds in cultivated pastures where this species had been seeded. Green and dry leafy material, native seeds, and insects were the primary foods of greater prairie-chickens in western Missouri (Toney 1980) and a part of east-central Kansas (Horak 1971) where native prairie pastures were predominant and cultivation was uncommon. In contrast, grains and cultivated legumes (Leguminosae) composed 50 to 90% of the summer diet in another part of east-central Kansas where agriculture was relatively common (Baker 1953). Oats (Avena sativa) and Korean lespedeza were the most important food items.

Greater prairie-chickens generally depend on cultivated grains for winter food (Evans 1968). Prairie-chickens in the Nebraska Sandhills began regular feeding in grain fields during the second week of October, within a few days of the first frost, and apparently were absent from extensive grassland areas that did not contain corn (Zea mays) fields (Mohler 1952). Winter migrations of prairie-chickens from two Sandhills refuges were associated with a lack of cultivated grain foods (Kobriger 1965).

Greater prairie-chickens in Missouri fed almost exclusively in cultivated fields throughout the late winter and early spring (Drobney and Sparrowe 1977). Decreased use of cultivated fields in March coincided with spring plowing and emergence of succulent green vegetation. Heavy use of cultivated grains for winter food has also been documented for prairie-chickens in Illinois (Yeatter 1943), Kansas (Baker 1953), Wisconsin (Hamerstrom et al. 1957), and Oklahoma (Jones 1963).

Corn is the staple grain food of greater prairie-chickens in all but the most southern range (Edminster 1954), where sorghum (Sorghum vulgare) becomes increasingly important (Johnsgard 1973). Stout-stemmed corn and sorghum are desirable because they remain standing during heavy snows (Evans 1968). Corn apparently is the most palatable winter food (Trippensee 1948), but should be left uncut or shocked after harvest (Edminster 1954). Small grains, such as oats, buckwheat (Fagopyrum esculentum), and millet (Panicum spp.), tended to collapse and become covered with snow in Minnesota, but corn remained available throughout the winter (Maertens 1973). Prairie-chickens in Missouri used sorghum when soybeans (Glycine max) were snow covered (Drobney and Sparrowe 1977). Standing corn and shocked sorghum were used most often in Nebraska, although rye (Secale cereale) stubble and Sudan grass (Sorghum sudanense) were used to some extent (Mohler 1952). Wheat, rye, and other grains are eaten in the winter but appear less preferred than corn, buckwheat, soybeans, and oats (Trippensee 1948). Soybeans are stouter stemmed than buckwheat and therefore are more resistant to collapsing under snow.

The greater prairie-chickens in high quality native tallgrass prairie of Kansas (Horak 1971) and Missouri (Toney 1980) may not require cultivated grains for winter food. Because Kansas and Missouri winters are relatively mild, native green vegetation, fruits, and seeds appear to be adequate winter foods. Grain field use that did occur was due to availability rather than necessity. Cottonwood buds (Populus deltoides) were used in Kansas when heavy snows covered pasture and grain field foods. Wild rose (Rosa carolina) was the primary winter food in Missouri and remained available throughout the season.

The buds of birches (Betula spp.), aspen (Populus spp.), elm (Ulmus spp.), hazelnut (Corylus spp.), and other woody plants are used by prairie-chickens throughout the winter in the northern parts of their range (Edminster 1954). Buds of maple (Acer spp.), elm, willow (Salix spp.), pine (Pinus spp.), and apple (Malus spp.) are listed as emergency winter foods in Wisconsin (Schmidt 1936). Budding apparently is less common in Illinois (Yeatter 1943) and Missouri (Korschgen 1962; Toney 1980) than in Wisconsin, although buds of cottonwood, red maple (A. rubrum), elm, apple, and other woody plants are used to some extent. However, prairie-chickens apparently cannot survive on a winter diet exclusively of buds. Feeding trials have shown that prairie-chickens lose weight and may starve to death when fed only buds (Hamerstrom et al. 1941).

### Water

Dew and succulent foods usually are adequate to provide water needs of prairie-chickens (Yeatter 1943; Edminster 1954; Horak 1971). During drought periods, however, Horak (1971) and T. E. Toney (Wildlife District Supervisor, Missouri Department of Conservation, Lockwood; pers. comm.) observed prairie-chickens drinking stockpond water.

### Cover

Grasslands are essential for greater prairie-chickens (Edminster 1954; Evans and Gilbert 1969; Kirsch 1974). Native tallgrass prairie plants probably provide superior cover in most respects, but other grasses, both indigenous and introduced, can substitute (Hamerstrom et al. 1957).

Prairie-chicken habitat in Oklahoma generally consisted of large units of tallgrasses intermixed with smaller shortgrass and midgrass units (Jones 1963). Grasses, mainly shortgrass, were used about 75% of the time for resting and feeding; forbs were used the remainder of the time. Grasses averaging 63.5 cm in height were used for escape cover. On state managed prairies in Missouri, rested hay units mainly provide cover, being selected over moderately grazed pasture (Toney, pers. comm.). However, light to moderately grazed native prairie was predominantly used for roosting, resting, and escape between February and May in areas of west-central Missouri where grazing was the primary land use (Drobney and Sparrowe 1977). Vegetation 20 to 90 cm in height was used significantly more than shorter vegetation for roosting and escape, whereas vegetation 10 to 19.9 cm was most often used for resting. Prairie-chickens on managed prairie in Missouri used cover ranging from 15 to 51 cm in height, averaging 25 to 28 cm (Toney, pers. comm.).

Greater prairie-chickens generally depend on dense herbaceous vegetation for winter cover (Kirsch 1974), although woody cover may be used during heavy snowstorms (Evans 1968). Prairie-chickens in the Nebraska Sandhills shifted from pasture to ungrazed bunchgrasses, such as little bluestem (Andropogon scoparius) and sand dropseed (Sporobolus cryptandrus), for winter resting and roosting cover (Mohler 1952). These dense grasses were typically 30.0 to 70.0 cm high with a dense layer of duff. Winter roosting sites in Oklahoma were small pockets of short grasses averaging 13.2 cm in height, within stands of taller grasses averaging 31.9 and 35.4 cm in height on either side of the sites (Jones 1963). Wintering prairie-chickens in Missouri preferred to roost in cover about 25.4 cm in height (Skinner 1974). Most avian species on Missouri prairies apparently decrease in number when vegetation exceeds 46 cm in height. Prairie-chickens observed in Missouri tended to avoid 90.0 cm tall cover unless no other was available (Toney, pers. comm.).

Brush and emergent aquatic vegetation supplement grass cover for wintering prairie-chickens in Minnesota (Patterson 1973). The amount of brush required in Minnesota is unknown, but prairie-chickens did not use areas with high brush densities. Prairie-chickens in Nebraska temporarily used sagebrush (Artemisia spp.) stands for winter roosting cover, but preferred dense native grasses (Mohler 1952). Shelterbelts can provide winter cover when herbaceous and natural woody vegetation are limited (Ordendurff 1941). Greater prairie-chickens sometimes burrow into deep, powdery snow for winter roosting (Evans 1968).

### Reproduction

Greater prairie-chicken leks generally are on elevated sites with relatively short and sparse vegetation (Jones 1963; Evans 1968; Horak 1971). Leks apparently are associated with adjacent taller grass cover. Prairie-chicken leks in Kansas were near larger pastures of tallgrass species and smooth brome (Bromus inermis) (Horak 1971). Leks in North Dakota were associated with idle tracts of grassland set aside under the Federal Conservation Reserve Program of 1956 and the Cropland Adjustment Program of 1965 (Kirsch et al. 1973). Idle tracts were not mowed or grazed and supported

dense herbaceous cover. Four of six leks were within 183 m of idle tracts and no leks were found on hayland or heavily grazed pasture without an adjacent idle tract. Availability of lek sites is apparently not a critical factor in Minnesota where a variety of sites are used, e.g., plowed or burned fields, mowed and unmowed grassland, grazed pastures, disked fields with mud and snow, frozen potholes, and wet potholes with mallards (Anas platyrhynchos) sitting among the grouse (Patterson 1973).

A lack of residual herbaceous vegetation (i.e., dried vegetation from the previous growing season) required for nesting and brood-rearing apparently is the most limiting factor for greater prairie-chickens throughout their range (Hamerstrom et al. 1957; Kirsch 1974). Population increases have been closely associated with the increased availability of nesting cover through grassland management (Westemeier 1973).

Grassland, preferably with a mixture of forbs and sedges (Carex spp.), is indispensable as nesting and brood rearing cover (Hamerstrom et al. 1957), although cultivated legumes, forbs, and crop stubble can be used when adjacent to grassland (Hamerstrom 1939; Schwartz 1945; Drobney and Sparrowe 1977).

Grassland vegetation was the primary nesting cover for prairie-chickens in Wisconsin (Hamerstrom 1939), Missouri (Schwartz 1945), Kansas (Baker 1953; Horak 1971), and Oklahoma (Jones 1963). Thirty-three percent of nest sites found in Illinois were in small grassland units that totaled only 4% of available nesting cover (Yeatter 1943). These units had not been grazed or farmed for several years and consisted mainly of bluegrass (Poa pratensis). The remaining nests were located in fallow fields, lightly grazed pasture, and redtop (Agrostis alba) fields.

The great majority of nests in a later Illinois study were found in redtop (Westemeier 1973). This was due to the availability of redtop and to grassland management practices that enhanced its quality as nesting cover. Redtop was best for nest cover when diversified with timothy (Phleum pratense), legumes, dewberries (Rubus flagellaris), and goldenrod.

Native prairie was the most important nesting and brood rearing habitat for greater prairie-chickens in Missouri, accounting for 60% of all nest locations (n = 35) and 40% of all brood locations (n = 15), even though about 55% of it was generally unused by prairie-chickens due to overgrazing by livestock (Drobney and Sparrowe 1977). Legumes were also important cover, accounting for 17% of nest locations and 19% of brood locations.

Predation on prairie-chicken nests in Minnesota apparently was associated with the proximity to brush; predation on incubating hens was associated with the presence of trees (Svedarsky 1979). Nesting hens in Illinois avoided nesting near woody cover on a sanctuary where predators were common (Westemeier and Buhnerkempe 1983).

Nesting hens apparently select residual cover that is tall and dense enough to conceal themselves and nests (Schwartz 1945; Horak 1971; Patterson 1973). Cover height at 23 active prairie-chicken nests in Missouri ranged

from 20 to 51 cm and averaged 45 cm (Drobney and Sparrowe 1977). Cover at brood locations in native pasture was between 10 and 19.9 cm in height. Both nesting hens and broods avoided heavily grazed pasture. Nest cover height in Oklahoma also averaged 45 cm and ranged from 25 to 70 cm (Jones 1963). Nest cover was taller and denser than what was normal for the surrounding tallgrass community. Vegetation height at nest sites in Kansas averaged 30.2 cm and ranged from 12.7 to 96.5 cm (Horak 1971). Brood cover averaged 30.7 cm. Svedarsky (1979) measured residual vegetation height and density at prairie-chicken nest sites in Minnesota using the visual obstruction method (Robel et al. 1970a). Vegetation at nests provided complete visual obstruction to an average level of 2.0 dm. Highly preferred smooth brome habitats provided significantly higher visual obstruction (2.7 dm) than all other types. For high quality nesting and brood rearing cover as well as winter roosting cover, Kirsch (1974) recommends that grasslands be managed to provide residual vegetation about 50.8 cm tall that is dense enough to completely conceal a nesting prairie-chicken. High quality nesting cover also provides winter roosting cover (Schwartz 1945; Mohler 1952; Hamerstrom et al. 1957).

Nesting prairie-chickens in Illinois preferred fields of uniformly structured native prairie grasses, or redtop that had been high-mowed to a height of about 30 cm (Westemeier 1973; Westemeier and Buhnerkempe 1983). This stubble was persistent through the winter and provided good visibility for standing prairie-chickens and ample concealment of nests. Prairie-chicken nests apparently were less susceptible to predation in uniformly structured vegetation because predators were attracted to the high densities of red-winged blackbird (Agelaius phoeniceus) and dickcissel (Spiza americana) nests that occurred in clumped prairie grasses (Westemeier and Buhnerkempe 1983).

Westemeier and Buhnerkempe (1983) believe that nesting prairie-chickens on the former mesic eastern prairies were limited to the drier well-drained ridges and bluff prairies. They suggest that the relatively uniform, vertically oriented stubble of high-mowed grasses on well-drained sites may be structurally similar to the high quality nesting cover of these former prairies.

Nesting prairie-chickens apparently do not use vegetation that is too tall and dense. Nesting hens in Illinois avoided old growth prairie grasses [big bluestem (Andropogon gerardi), Indiangrass (Sorghastrum nutans), and switchgrass (Panicum virgatum)] that had developed an impenetrable layer of cane-like residual cover (Westemeier 1973), and tall, rank weed growth (Yeatter 1943). Svedarsky (1979) and Buhnerkempe et al. (1984) agree that cover > 1 m in height may not be suitable for prairie-chicken nesting. Buhnerkempe et al. (1984) suggest that prairie-chicken habitat in Illinois be managed so that 90% of the standing vegetation is < 40 cm in height, but dense up to that level, and so that the tallest vegetation is no more than 80 cm in height.

Declines in redtop use by nesting prairie-chickens in Illinois were attributed to excessive litter buildup, which promoted cold, wet soil conditions during nest initiation, impeded movements, and reduced food availability, especially for young chicks (Westemeier 1973). Prescribed burning rejuvenated the grassland and resulted in increased prairie-chicken use by the second nesting season following the burn.



Forbs are an important habitat component for broods because they support relatively high populations of insects (Jones 1963) and can provide shade during the heat of the day (Robel et al. 1970b; Horak 1971). Hens in Oklahoma (Jones 1963) and Minnesota (Svedarsky 1979) typically moved their newly hatched broods to disturbed sites, such as old fields and cultivated pastures, where forbs were abundant.

### Interspersion, Composition, and Movements

Greater prairie-chickens are considered to be nonmigratory, although distances between breeding grounds and wintering areas commonly are 1.6 to 4.8 km (Edminster 1954). Long-range movements apparently indicate habitat deficiencies (Hamerstrom and Hamerstrom 1949). Winter night roosts of greater prairie-chickens in central Wisconsin commonly were 0.4 to 0.8 km from feeding fields and seldom were more than 2.0 km away (Hamerstrom and Hamerstrom 1949). Distances between winter roosting and feeding sites in eastern Kansas ranged from 0.2 to 3.2 km and averaged 1.2 km (Horak 1971). Daily movements of male flocks in Missouri during winter appeared to reflect spatial arrangements of habitat components (Drobney and Sparrowe 1977). Average daily movements were greatest in February and ranged from 2.8 to 6.0 km. This was due to greater distances traveled to roosting and loafing sites, intensified food seeking, and more frequent visits to leks during this period. Movements to wintering grounds in Michigan are often about 6.4 to 8.0 km, and largely depend on food and roosting cover availability (Ammann 1957). Evans and Gilbert (1969) considered grain fields > 9.7 km apart to be of no value for prairie chickens in Colorado; distances < 6.4 km were considered optimal.

Typical prairie-chicken habitat in South Dakota consisted of 74.0% grassland (including hayland), 21.0% cultivated land (primarily small grains), 3.5% weedy cover, and 1.5% woody cover (Janson 1953). Two townships of the best prairie-chicken range in Kansas contained 62.9 and 66.4% permanent grassland, respectively (Baker 1953). Feed grains (corn, wheat, sorghum, and soybeans) formed 18.6 and 16.6% of the townships, respectively.

### Special Considerations

Modern farming practices, such as fall plowing, greatly reduce the availability of waste grain for winter food. Corn fields used by cattle after the fall harvest in Missouri provided little waste grain for prairie-chickens by late winter (Drobney and Sparrowe 1977).

## HABITAT SUITABILITY INDEX (HSI) MODEL

### Model Applicability

Geographic area. This model was developed for application throughout the historic range of the greater prairie-chicken (Fig. 1).

Season. This model was developed to evaluate the year-round habitat of the greater prairie-chicken.

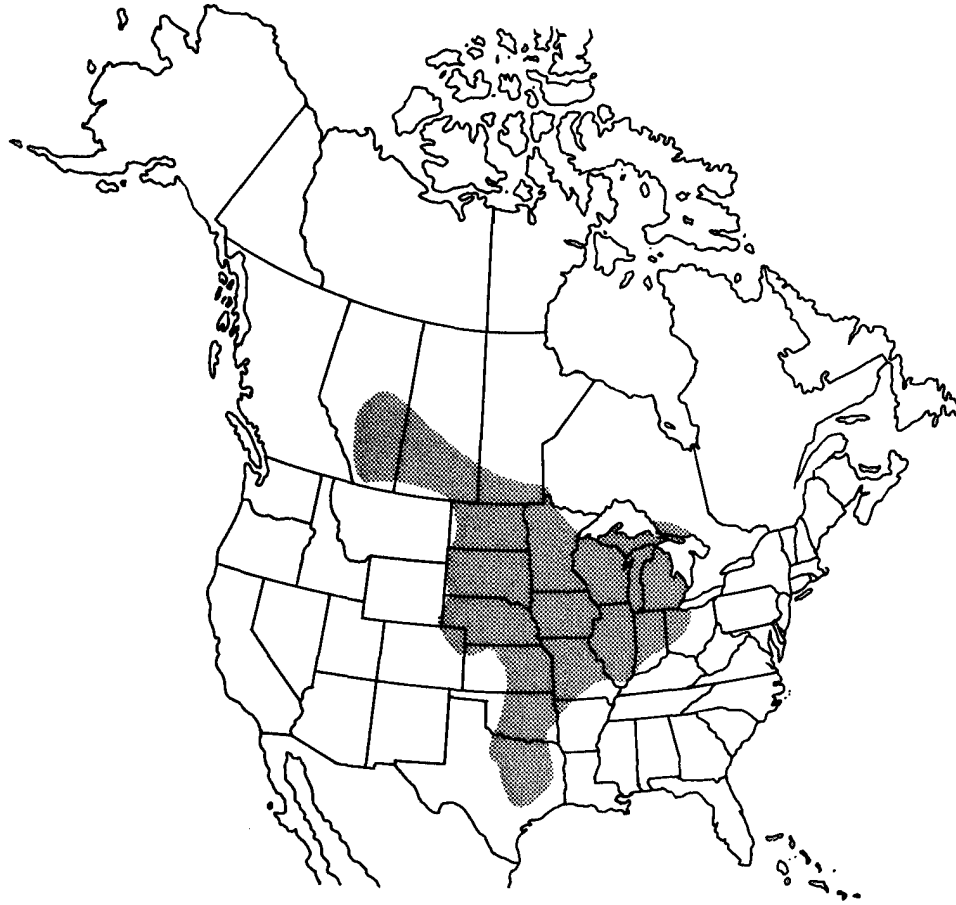

Figure 1. The historic range of the greater prairie-chicken (from Johnsgard 1983).

Cover types. This model can be applied in Grassland (G); Pasture and Hayland (P/H); Cropland (C); and Herbaceous Wetland (HW) of temporarily flooded, intermittently flooded, and artificially flooded water regimes, that are dry during the nesting season (terminology follows that of the U.S. Fish and Wildlife Service 1981a).

Minimum habitat area. A minimum of 10.4 km<sup>2</sup> of average quality cover has been suggested as the contiguous area required for a greater prairie-chicken population in northern Michigan farmland (Ammann 1957). Edminster (1954) believes that an isolated unit of range must support several flocks to sustain prairie-chickens through periods of low numbers. He estimates that 2,025 to 4,050 contiguous hectares of habitable range are required, with 33 to 40% being grassland. A minimum of 2.6 km<sup>2</sup> of high quality grassland has been estimated as the area requirement to provide all the prairie-chicken's habitat needs in Indiana (Barnes 1952), but Kirsch (1974) believes that small areas

would not carry prairie-chickens through natural disasters or permit sufficient latitude for habitat management. He recommends 5.2 km<sup>2</sup> of high quality grassland habitat as the minimum for prairie-chicken management units. If not contiguous the smallest blocks should be 64.8 ha with a minimum width of 0.8 km; all blocks should be contained within 20.7 km<sup>2</sup>. In Illinois, 607.5 ha of grassland sanctuary is expected to support 4 to 12 times the supposed extinction threshold of 50 birds and provide a safety margin against factors such as pheasant (Phasianus colchicus) competition, oil development activity, heavy predation of nests, and increasing land use disturbance around the sanctuaries (Illinois Natural History Survey 1984).

For application of this model, the minimum area required for greater prairie-chickens is assumed to be 5.2 km<sup>2</sup> of grassland, pasture and hayland, or herbaceous wetland cover types, within a 20.7 km<sup>2</sup> area, with the smallest blocks being  $\geq 0.8$  km wide. No information was found in the literature regarding the minimum amount of cropland needed for prairie-chickens.

Verification level. This model is a hypothesis of species-habitat relationships and not a statement of proven cause and effect relationships. Preliminary drafts were reviewed by:

- P. M. Arnold (Arrowwood National Wildlife Refuge, U.S. Fish and Wildlife Service, Pingree, ND);
- B. C. Bell (U.S. Fish and Wildlife Service, Atlanta, GA);
- K. E. Evans (Intermountain Forest and Range Experiment Station, U.S. Forest Service, Ogden, UT);
- J. R. Foster (Arrowwood National Wildlife Refuge, U.S. Fish and Wildlife Service, Pingree, ND);
- A. D. Kruse (Northern Prairie Wildlife Research Center, U.S. Fish and Wildlife Service, Jamestown, ND);
- L. J. O'Neil (Waterways Experiment Station, U.S. Army Corps of Engineers, Vicksburg, MS);
- T. H. Roberts (Waterways Experiment Station, U.S. Army Corps of Engineers, Vicksburg, MS);
- T. E. Toney (Missouri Department of Conservation, Lockwood, MO);
- G. W. Towns (U.S. Fish and Wildlife Service, Denver, CO);
- J. S. Wakeley (School of Forest Resources, The Pennsylvania State University, University Park, PA); and
- R. L. Westemeier (Illinois Natural History Survey, Effingham, IL).

Their review comments and suggestions have been incorporated into the model.

## Model Description

Overview. This model is divided into three components, two representing life requisites of the greater prairie-chicken and one representing habitat composition (interspersions and proportions of cover types providing life requisites). Winter food and nesting cover are assumed to always be the most limiting factors for greater prairie-chickens; therefore, they constitute the life requisites in this model. Winter food is provided by the cropland cover type; nesting cover is provided by grassland, pasture and hayland, and herbaceous wetland cover types. The overall Habitat Suitability Index (HSI) is determined from suitability indices for the life requisites and for habitat composition. Life requisite suitability indices are derived from suitability indices for habitat variables, which are associated with habitat characteristics within cover types. Suitability indices for habitat composition are derived from spatial variables, which are primarily associated with the spatial arrangement of cover types.

This model assumes that optimum habitat conditions for the prairie-chicken exist when winter food and nesting requirements are met within a prescribed area. Prairie-chickens inhabiting extensive tallgrass prairie habitats appear to depend less on cultivated grains for winter food than do populations within other areas of their range. The assumed relationships in the winter food component may therefore not always be applicable in tallgrass communities. Individuals who wish to apply the model to extensive areas of tallgrass prairie should determine whether or not the winter food component of this model is applicable to their particular situation.

Winter food component. This model assumes that present-day greater prairie-chickens generally require a source of cultivated crop foods for winter sustenance. Winter food suitability in this model is a function of the types of crops present and their availability. Corn and sorghum apparently are the most important crops because of their palatability and resistance to collapsing under snow. Soybeans, buckwheat, and oats are used to a lesser extent, but seem preferred over wheat, rye, and other grains. The relatively stout-stemmed soybeans are somewhat resistant to collapsing under snow, but less so than corn and sorghum. Waste soybeans tend to be less persistent in the field than corn and are more easily covered during post harvest tillage (Walker 1981; Warner et al. 1985). For the purpose of this model, the following crop types have been rated in order of suitability based on the apparent preferences of prairie-chickens and the crop's availability during winter: (A) corn and sorghum; (B) soybeans; (C) buckwheat or oats; (D) rye, wheat, or other grains; and (E) nongrain crops. The suitability indices (SIV1) corresponding to crop types are shown in Figure 2.

Type of crop present.

- A. Corn or sorghum
- B. Soybeans
- C. Buckwheat or oats
- D. Rye, wheat, or other grains
- E. Nongrain crops

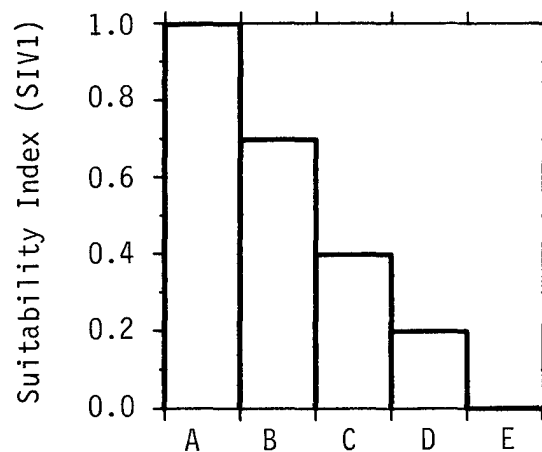

Figure 2. The relationship between type of crops present and winter food suitability for the greater prairie-chicken.

The availability of food for wintering prairie-chickens is influenced by crop management during the fall and winter and the efficiency of the harvest (Moen 1983). The efficiency of harvesting is variable and difficult to measure (Moen 1983), and measuring the amount of waste grain in fields is time consuming and costly (Frederick et al. 1984). This model therefore infers waste grain availability from fall and winter crop management practices. In general, harvesting removes about 93 to 97% of the grain from fields (U.S. Fish and Wildlife Service 1981b; Moen 1983). Unharvested grainfields (e.g., food plots intended for wildlife or patches of crops inaccessible to harvesters) could therefore potentially provide 25 times more grain for wintering prairie chickens than harvested fields. Edminster (1954) suggests that 0.4 ha of unharvested grain can support about 30 prairie-chickens throughout the winter.

If crops are harvested, more waste grain should be available if the residue is left undisturbed than if tilled. Post-harvest tillage tends to bury waste grain under the soil where it cannot be reached by prairie-chickens, and reduces cover provided by stubble (Moen 1983). Moldboard plowing and disk plowing overturn the top layer of soil, with moldboard plows burying more grain than disk plows. Chisel plows stir the soil without turning under crop residues and should therefore yield more waste grain than moldboard or disk plows. Harrows till the soil less deeply than plows and do not completely bury crop residue (Walker 1981). However, some harrows (e.g., offset disk) can be much heavier than others and till the soil to greater depths. Baling and grazing crop residue also reduces the amount of waste grain that will be available during the winter. Silage harvesting is relatively consumptive, and little waste grain can be expected to remain among the stubble.

Baldassarre et al. (1983) investigated changes in waste corn abundance following various cropland management practices on freshly harvested fields in Texas. An average of 364 kg/ha waste grain occurred in fields following harvest. Disking harvested fields to depths < 20 cm reduced total waste grain

by 77%, but increased the availability of remaining grain (63 kg/ha) by reducing stalk and leaf litter and breaking up ears of corn into smaller pieces. Further grain loss from subsequent disking was minimal, but one disking followed by deep (30 to 45 cm) plowing reduced total waste grain by 97%, leaving only 6 kg/ha. Grazing of crop residue by cattle reduced the total amount of waste grain by 84%. However, grazing generally occurred in fields where waste grain was most abundant following the harvest and substantial amounts of grain (73 kg/ha), remained in the fields when grazing was terminated. Hand salvaging by farm workers reduced waste grain by 58%. However, hand salvaging also occurred in fields with abundant waste initially, and much grain (333 kg/ha) remained following this activity.

Warner et al. (1985) evaluated the early winter abundance of waste corn and soybeans relative to common tillage practices and grazing during a two year period in Illinois. Tillage practices were classified as untilled, intermediately tilled (conservation tillage systems, e.g., chisel plowing and offset disking), and moldboard plowed. No moldboard plowed soybean fields were encountered. A multiple regression model was developed to predict the abundance of remaining waste grain following various post-harvest tillage operations. Waste corn in untilled fields measured 430.5 kg/ha in the first year and 273.7 kg/ha in the second year. During each of the respective years, intermediately tilled corn fields contained 45.4 and 65.0 kg/ha waste corn, or 90 and 76% less than the untilled fields. Moldboard plowed and grazed-untilled corn fields contained 3.7 and 68.7 kg/ha waste corn respectively, or 99 and 84% less than the untilled fields, during the first year (data were not available for moldboard plowed and grazed-untilled fields during the second year). Waste soybeans in untilled fields measured 47.9 and 63.3 kg/ha during each of the respective years. Intermediately tilled soybean fields contained 12.3 and 11.5 kg/ha waste grain each respective year, or 74 and 82% less than untilled fields. Grazed-untilled soybean fields contained 39.6 kg/ha waste grain, or 19% less than untilled fields during the first year (data for grazed-untilled soybean fields were not available during the second year). Table 1 shows the regression model's predictions of early winter abundance of waste corn relative to common fall tillage systems in Illinois.

Exact fall and winter crop management practices can be difficult to determine in the field and resulting waste grain abundance can vary. Therefore, fall and winter crop management practices are divided into four broad categories and assigned suitability indices (SIV2) based on assumed winter food availability (Fig. 3). The first category (A) includes fields harvested for grain that have been left undisturbed or have been hand salvaged. Hand salvaging can reduce waste grain by 58% (Baldassarre et al. 1983), but this practice may be undetectable in the field, and much waste grain (333 kg/ha) can remain as potential food for prairie-chickens. The second category (B) includes fields harvested for grain that have had the soil surface and crop residue stirred (chisel plowed) or lightly turned (single disking). Fields in the third category (C) are harvested for grain and then grazed by livestock during the fall and winter. The final category (D) includes fields that have had the crop residue removed (e.g., baled or harvested for silage) or deeply turned under the surface by moldboard plowing or several passes ( $\geq 2$ ) of other soil tillage equipment. Crop management practices that are not discussed above should be compared to those that are (in terms of waste grain yields), and then be assigned an appropriate suitability value.

Table 1. Predicted early winter abundance of waste corn relative to common fall tillage systems in Illinois (adapted from Warner et al. 1985).

Tillage system	Waste corn abundance (kg/ha)	Percent decrease relative to untilled fields
Untilled	359	
Disk (tandem)	262	27
Chisel (straight-shank)	166	54
Chisel (twisted-shank)	30	92
Chisel (straight-shank) - disk (tandem) <sup>a</sup>	25	93
Chisel (straight-shank) - disk (offset) <sup>a</sup>	9	97
Chisel (twisted-shank) - disk (tandem) <sup>a</sup>	6	98
Chisel (twisted-shank) - disk (offset) <sup>a</sup>	3	99
Moldboard plow	2	99

<sup>a</sup>Two-pass tillage operations using both chisel plows and disks.

Fall and winter crop management.

- A. Crop residue hand salvaged or left undisturbed.
- B. Crop residue lightly tilled (single pass with chisel plow or disk).
- C. Crop residue grazed by livestock.
- D. Crop residue moldboard plowed, two-pass tilled, or baled, or crop harvested for silage.

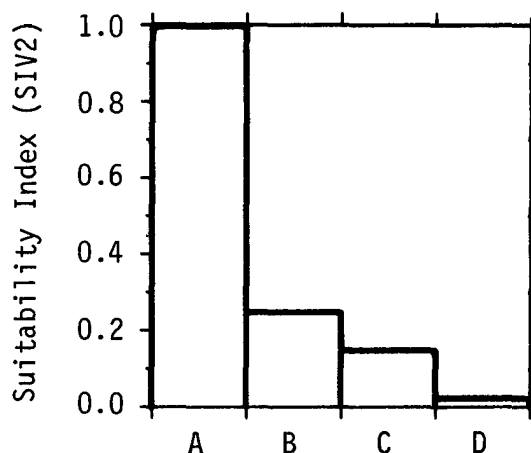

Figure 3. The relationship between fall and winter crop management practices and winter food suitability for the greater prairie-chicken.

Although unharvested crops provide a source of abundant grain, they are not assigned a suitability value for fall and winter crop management. The value of unharvested crops as an abundant winter food source will be treated during HSI calculations so that their contribution to winter food suitability is considered. If more than one management practice occurs on a field, the lowest corresponding suitability index should be used for HSI calculations.

The suitability of winter food is a function of the type of crop present, and fall and winter crop management practices. Equation 1 is used to determine the suitability index of the winter food life requisite (SIWF) in harvested cropland. Equation 2 is used to determine SIWF in unharvested cropland.

$$\text{SIWF} = (\text{SIV1} \times \text{SIV2})^{1/2} \quad (1)$$

$$\text{SIWF} = \text{SIV1} \quad (2)$$

The geometric mean in Equation 1 represents an assumed compensatory relationship between SIV1 (for type of crop present) and SIV2 (for fall and winter crop management); e.g., a relatively beneficial crop management practice can moderate the negative effect of a low quality crop type by allowing a greater abundance of the crop to remain in the field after harvesting.

Nesting cover component. The lack of residual herbaceous vegetation for nesting and brood rearing is documented in the literature as an important limiting factor for greater prairie-chickens throughout their range. However, R. L. Westemeier (Illinois Natural History Survey, Effingham; pers. comm.) does not believe that residual herbaceous vegetation is essential for broods after the nest is abandoned [usually within 24 hrs after the last chick has hatched (Lehmann 1941)]. Broods can generally use several other types of cover that are not well suited for nesting; e.g., croplands and moderately grazed grassland. Therefore, this model considers the lack of residual herbaceous vegetation for nesting cover to be the limiting factor during the reproduction season.

Residual herbaceous vegetation is important nesting cover because little current growth is available at the onset of nesting. Residual vegetation for nesting cover must be tall and dense enough during the spring to conceal an incubating hen. Height and density can be conveniently measured using the visual obstruction reading (VOR) method of Robel et al. (1970a), which measures the height in decimeters to which the vegetation completely obstructs vision of an object when sighted from a height of 1.0 m and a distance of 4.0 m (e.g., a VOR of 1.0 provides 100% visual obstruction to a height of 1.0 dm or 10.0 cm). A VOR of 2.0 dm can conceal prairie-chicken nest sites, but preferred cover can provide a somewhat higher VOR [e.g., 2.7 in smooth brome



habitats of Minnesota (Svedarsky 1979)]. However, it is more practical to estimate nesting cover suitability by calculating an average VOR over an entire area so that nest locations need not be known.

The overall height of vegetation at nest sites in Oklahoma was more than twice that of vegetation 1 m from the nest (Jones 1963). Nest site vegetation was also higher than surrounding vegetation for plains sharp-tailed grouse (*Tympanuchus phasianellus jamesi*) in North Dakota (Kohn 1976). This model therefore assumes that an average VOR of 2.0 to 3.0 dm over an entire nesting habitat area in the spring would provide areas of taller and denser vegetation for nest sites, and would represent optimum nesting cover conditions (Fig. 4).

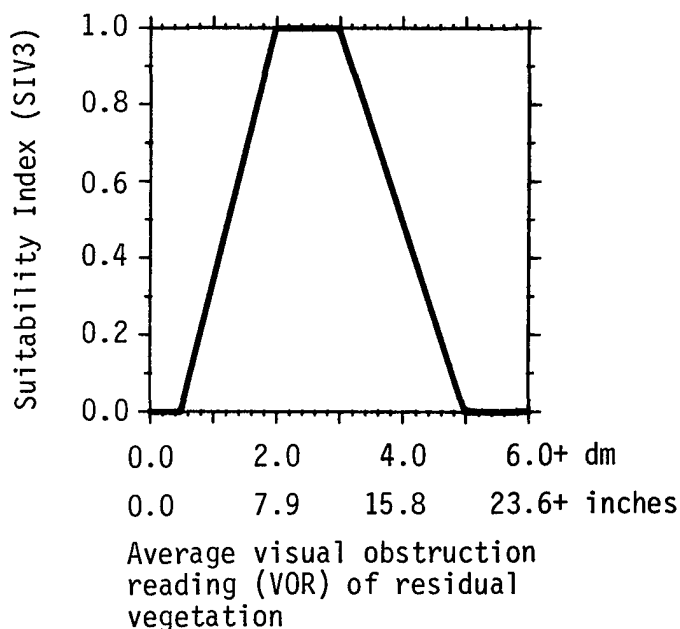

Figure 4. The relationship between the average visual obstruction reading (VOR) of residual vegetation and nesting cover suitability for the greater prairie-chicken.

Suitability is assumed to decrease as the average VOR falls below 2.0 dm. No information was found in the literature regarding the minimum VOR required for nesting prairie-chickens, but they apparently will not use vegetation < 13 to 20 cm in overall height at nest sites. The lowest average VOR obtained during the spring from a pasture containing plains sharp-tailed grouse nests in North Dakota was 0.55 dm (Kohn 1976). It is therefore assumed in this model that zero suitability for nesting cover conditions will be reached when the average VOR for nesting habitat decreases to 0.5 dm.

Prairie-chickens tend to avoid vegetation that is excessively tall and dense. Buhnerkempe et al. (1984) indicated that cover > 1 m tall may not be suitable prairie-chicken nesting cover, and recommended that Illinois habitat be managed so that the tallest vegetation is ≤ 80 cm in height. Westemeier (pers. comm.) suggests that nesting cover suitability should drop to 0.0 at

some point > 4.0 dm. Toney (pers. comm.) believes prairie-chickens would not use cover with a VOR > 4.0 dm unless no other was available. Therefore, suitability in this model decreases as the average VOR exceeds 3.0 dm until zero suitability is reached at an average VOR of 5.0 dm.

Hayfields are often used by nesting prairie-chickens, however, these fields are suitable only for short periods during the year. Mowing operations can cause nest destruction and hen mortality, and remove vegetation required for nest cover. Therefore, hayfields that will be mowed during the nesting season should be assigned a suitability index of 0.0. Idle hayfields and those that will be mowed after the nesting season [including alfalfa (Medicago sativa) and clover (Trifolium spp.) fields] should be assigned a suitability index corresponding to the average VOR. The average VOR of residual vegetation is the only habitat variable in this model that represents nesting cover suitability. Therefore, the suitability index for the nesting cover life requisite (SINC) is equal to the suitability index for the average VOR of residual vegetation (SIV3), as shown in Equation 3.

$$SINC = SIV3 \quad (3)$$

Composition component. Winter food and nesting cover are supplied by different cover types. The distance between cover types providing the life requisites and their proportions are important in determining the overall potential habitat value of a site.

Cover types providing winter food and nesting cover must be within a suitable distance of each other to be available for prairie-chicken use. Daily winter movements of prairie chickens are commonly 0.2 to 0.8 km between roosting and feeding sites, and generally do not exceed 2.0 or 3.0 km. Based on these movements data and suggestions by Toney (pers. comm.) and Westemeier (pers. comm.), the optimum distance between cover types providing winter food and nesting cover in this model is  $\leq 1.6$  km; i.e., the suitability index (SIV4) equals 1.0 (Fig. 5). Suitability decreases as the distance approaches 6.4 km, where suitability becomes zero.

The proportions of cover types providing nesting cover and winter food are expressed in this model as percent equivalent optimum area. These are spatial variables that represent the percent area that provides a life requisite at optimum levels (these are actually equivalent figures, i.e., 100% of the area at a suitability index of 0.5 is equal to 50% of the area at an optimum 1.0 value). The calculation of percent equivalent optimum area is explained in the "HSI determination" section of this model.

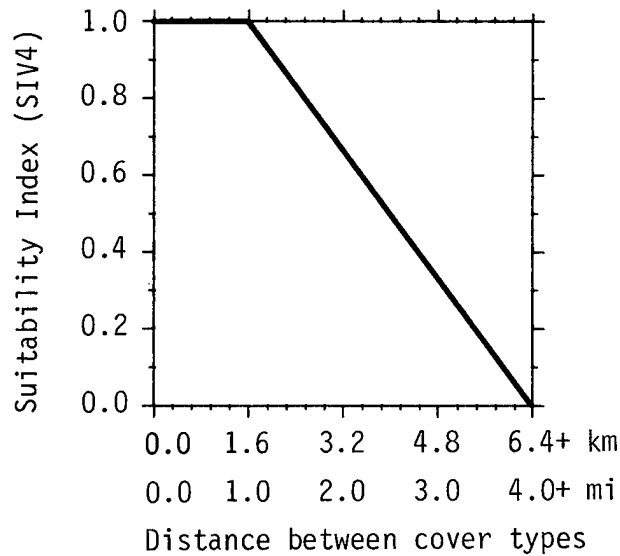

Figure 5. The relationship between the distance separating cover types providing different life requisites and habitat suitability for the greater prairie-chicken.

Cropland is assumed to represent available winter feeding habitat. Data associating densities of prairie-chickens with various proportions of cropland are useful in estimating the optimum proportion of winter food resources required for maximum site suitability. The average proportion of feed grains (corn, wheat, sorghum, and soybeans) on two townships of the best prairie-chicken range in Kansas was 16.6 and 18.6% (Baker 1953). Typical prairie-chicken habitat in South Dakota contained 21% cropland (Janson 1953). Very dense populations were found on ranges in Missouri with as little as 16% cultivated land (Schwartz 1945), and important breeding areas in Nebraska had no more than 10% cropland (McClure 1943). Based on this information, it is assumed that the optimum proportion of winter food available on any site is 15% or more. Suitability is assumed to decrease as the proportion of cropland falls below 15%. The relationship between the percent area providing equivalent optimum winter food and winter food suitability indices (SIV5) is shown in Figure 6.

Hamerstrom et al. (1957) compiled land use and prairie-chicken population data from habitats throughout the bird's range. They concluded that the number of displaying males plotted against proportion of permanent grassland provides a rough index to habitat quality (population numbers were compared at similar points in time to avoid the effect of cyclic fluctuation). However, these data have limitations. Some of them have been interpolated or estimated to round numbers, and the potential influence of grassland condition and winter food availability on prairie-chicken density was not considered. The variation in size and shape of the census areas also could have introduced some bias. Nevertheless, the data are assumed to be adequate to show a relationship between percent grassland and population densities. For the purpose of this model, these data have been plotted as a linear regression and are shown with the regression line in Figure 7. The coefficient of determination ( $r^2 = 0.90$ ) shows that 90% of the variation in male prairie-chicken density is attributed to variation in the proportion of permanent grassland.

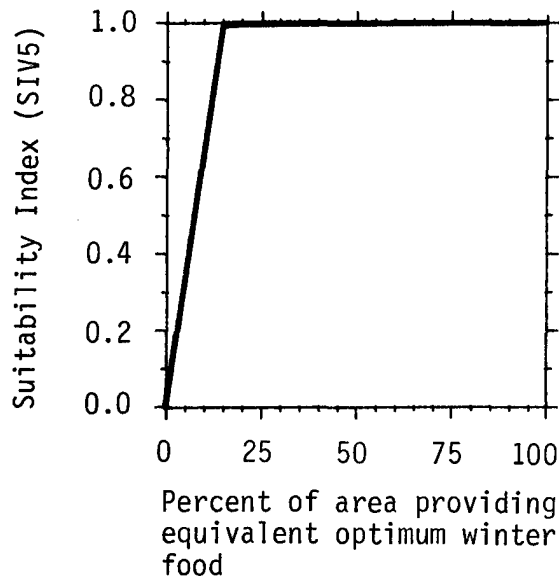

Figure 6. The relationship between the percent area providing equivalent optimum winter food and winter food suitability for the greater prairie-chicken.

The trend shown is that populations were lowest when permanent grassland constituted about 30% of the total area under consideration. Populations became increasingly larger as the proportion of permanent grassland increased to about 80%. Two data points (denoted by the symbol + in Fig. 7) that did not agree with the general trend have been omitted from the regression calculation. However, Hamerstrom et al. (1957) believed that one of these [25% permanent grassland with 26.8 males/section (2.6 km<sup>2</sup>) in Indiana] may have reflected distortion due to small sample size, and that the other (73% permanent grassland with only two or three males/section), taken from South Dakota, suggests that the carrying capacity in this most western part of the bird's range may be relatively low. This area was intensively farmed or grazed leaving only narrow strips of relatively undisturbed grassland in the rough breaks along the Missouri River and its tributaries to support most of the prairie-chickens. Another data point that did agree with the general trend ( $\geq 48\%$  permanent grassland with 12.1 males/section) was also omitted because the actual amount of permanent grassland present was questionable.

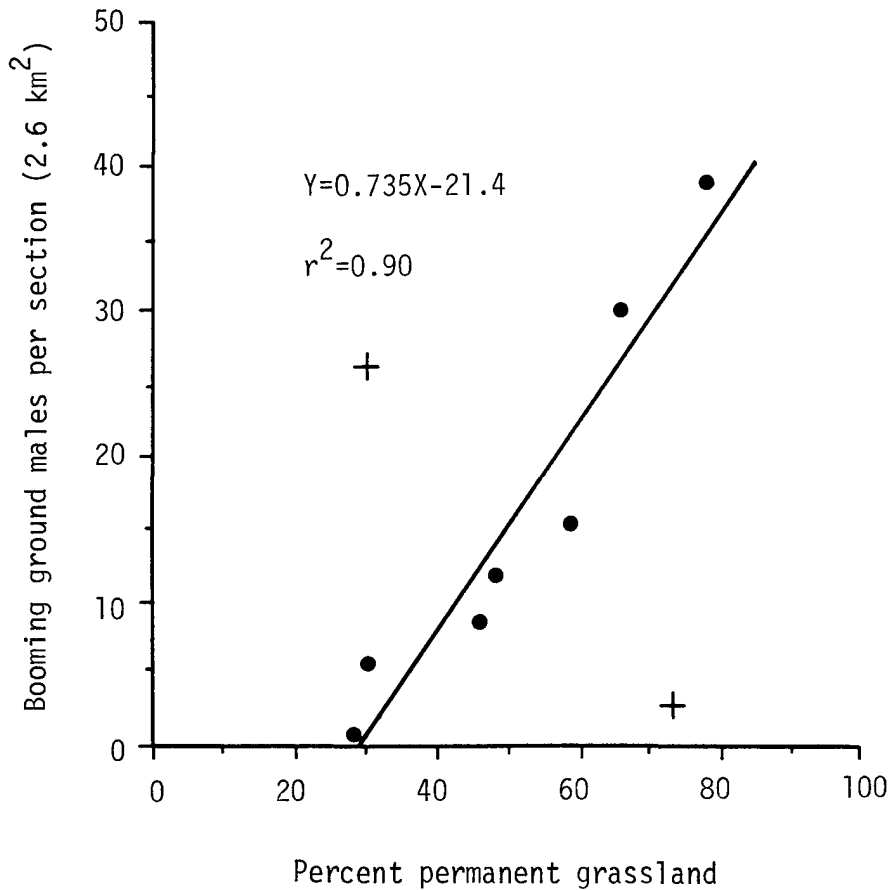

Figure 7. The relationship between percent permanent grassland and prairie-chicken density (adapted from Hamerstrom et al. 1957). The data points denoted by the symbol + have been omitted from the regression calculation.

It is assumed in this model that permanent grassland represents available nesting habitat, and data from Figure 7 are used to estimate the optimum proportion of nesting habitat required for maximum suitability of the nesting cover life requisite. Based on the data in Figure 7, this model assumes that the optimum proportion of nesting habitat in a given area is 80% or more. Suitability is assumed to decrease as the proportion of nesting habitat decreases. The regression equation in Figure 7 predicts that an area with 80% permanent grassland will support 37 male prairie-chickens/section. The suitability index (SIV6) can therefore be derived by modifying the regression equation as shown in Equation 4:

$$SIV6 = \frac{0.735X - 21.4}{37} \quad (4)$$

where  $X$  = the percent of the area providing equivalent optimum nesting cover

Note that if SIV6 is  $> 1.0$ , a value of 1.0 should be used for SIV6 in further calculations. If SIV6 is  $< 0.0$ , a value of 0.0 should be used in further calculations.

Figure 8 shows the relationship between the percent of area providing equivalent optimum nesting cover and nesting cover suitability.

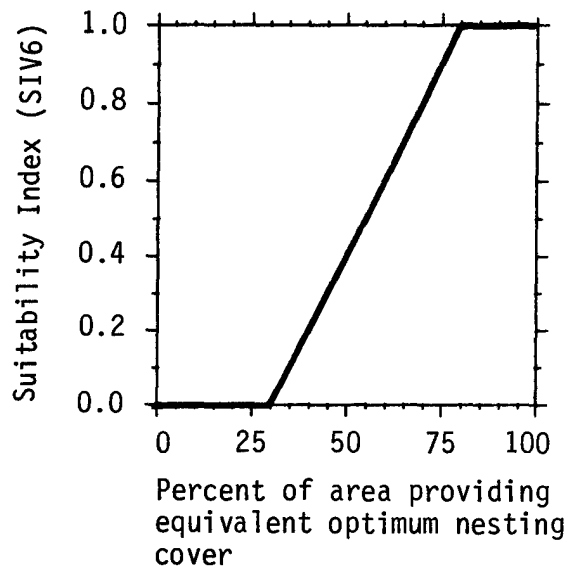

Figure 8. The relationship between percent area providing equivalent optimum nesting cover and nesting cover suitability for the greater prairie-chicken.

It should be noted, however, that the relationship shown in Figure 7 may not always hold true. The proportion of permanent grassland supporting prairie-chickens in Missouri ranged from 39 to 85% with no apparent relationship between the amount of permanent grassland and prairie-chicken population density above the 39% figure (Schwartz 1945). Apparently as little as 10 to 15% permanent grassland has supported low lingering populations of prairie-chickens in South Dakota (Hamerstrom et al. 1957).

The curves in Figures 6 and 8 represent only the relationships between the areas providing each life requisite and the suitability of the respective life requisites. Therefore, 100% of an area providing winter food is considered optimum in Figure 6, even though such an area would provide no nesting cover. The value of this area for nesting cover would become evident by the relationship in Figure 8.

HSI determination. The following steps should be used to calculate the HSI:

1. Identify cover types on the study area that provide a life requisite (the nesting cover life requisite is provided by grassland, pasture and hayland, and herbaceous wetland; the winter food life requisite is provided by cropland). Individual areas of like cover types providing nesting cover can be considered together as a single cover type area for sampling.

Because this model classifies crop types into five categories and fall and winter crop management practices into five categories (including no harvesting), there are 25 possible combinations or subtypes of cropland within the cropland cover type to which a field can belong. Areas of unharvested crops within a harvested field should be treated as a separate subtype. The area of fields of like subtypes can be combined and treated as a single subtype. Each cropland subtype should be treated in this model as an individual cover type for further calculations.

2. For each cover type providing a life requisite, a suitability index must be calculated for the distance to the nearest cover type providing the other life requisite. This is accomplished by selecting random points on a map in each cover type providing nesting cover or winter food and measuring the distance to the edge of the nearest cover type providing the other life requisite. Enter each distance measurement into the suitability index graph in Figure 5, record the individual suitability indices, and calculate the average suitability index for each cover type.
3. Determine the relative area (%) of each cover type providing a life requisite. Equation 5 is used for cover types providing nesting cover; Equation 6 is used for cropland subtypes.

$$\text{Relative Area (\%)} \text{ for Cover Type A} = \frac{\text{Area of Cover Type A}}{\text{Total Area of All Cover Types Used by the Greater Prairie-Chicken}} \times 100 \quad (5)$$

$$\text{Relative Area (\%)} \text{ for Cropland Subtype A} = \frac{\text{Area of Subtype A}}{\text{Total Area of All Cover Types Used by the Greater Prairie-Chicken}} \times 100 \quad (6)$$

Consideration of relative area assures that each nesting cover type and cropland subtype influences the overall life requisite suitability indices in proportion to their relative area.

If an unharvested cropland subtype exists, its relative area should be modified by multiplying it by a weighting factor. For example, if harvesting yields 7% waste grain, an unharvested field would contain 14 times (7 divided into 100) more grain than an untilled harvested field. The relative area of unharvested cropland should therefore be multiplied by a factor of 14, resulting in a modified relative area figure. This has the effect of increasing the winter food value of unharvested cropland relative to those that are harvested. This figure should be treated the same as the relative area figures for the other subtypes in further calculations. The actual weighting factor used should be determined from local data on harvesting efficiency (Note: if unharvested cropland exists, the sum of the relative areas of all cover types on the study area will be > 100%).

4. Modify the relative area (%) of each cover type by multiplying it by the cover type's average suitability index for the distance between cover types. This determines the relative area (%) of the cover types that are assumed to be available for prairie-chicken use.
5. Compute the suitability index for the winter food and nesting cover life requisites for each appropriate cover type by collecting data for each habitat variable, entering this data into the proper suitability index graph and using the resulting suitability indices in the appropriate life requisite equations.
6. To determine the percent area in equivalent optimum condition for either life requisite, multiply the available area (%) (from step 4) for each cover type by the life requisite value for that cover type (from step 5). Sum the products of this multiplication across all cover types for the nesting cover life requisite and all cropland subtypes for the winter food life requisite. The sum for each life requisite is the equivalent percent area that is assumed to provide that life requisite at optimum levels.
7. Enter the summed value from step 6 for winter food into the suitability index graph in Figure 6 and the summed value for nesting cover into Equation 4 or the suitability index graph in Figure 8. Based on the limiting factor concept, the HSI is equal to the lower of the suitability indices for the percent area providing equivalent optimum winter food (SIV5) or the percent area providing equivalent optimum nesting cover (SIV6).

Users who feel that the treatment of winter food in this model is not applicable to their study area may wish to evaluate only nesting cover. The model assumes that the value of nesting cover for greater prairie-chickens depends on the amount (area coverage) and quality (height and density) of herbaceous vegetation. Optimum nesting conditions are assumed to exist when at least 80% of the area supports herbaceous vegetation yielding a mean visual obstruction reading (VOR) of at least 2.0 dm. This value is determined by first obtaining a mean VOR from each cover type supplying nesting cover. The relative area of these types should be determined (step 2), and then multiplied



by their respective suitability indices for mean VOR (SIV3). These values are summed and the total entered into the graph in Figure 8. The HSI is equal to the resulting suitability index (SIV6).

Application of the Model

Summary of model variables. Winter food and nesting cover are assumed in this model to be the most limiting factors for greater prairie-chickens. The value of winter food is a function of the type of crops present and fall and winter crop management practices. The value of nesting cover is a function of the height and density of residual vegetation. Because winter food and nesting cover are provided by different cover types, the distance between them and the proportion of the study area providing them are considered in determining the overall habitat value of an area. The relationship between habitat variables, life requisites, cover types, and the HSI is illustrated in Figure 9 (spatial variables are not shown). Definitions of variables and suggested field measurement techniques are provided in Figure 10.

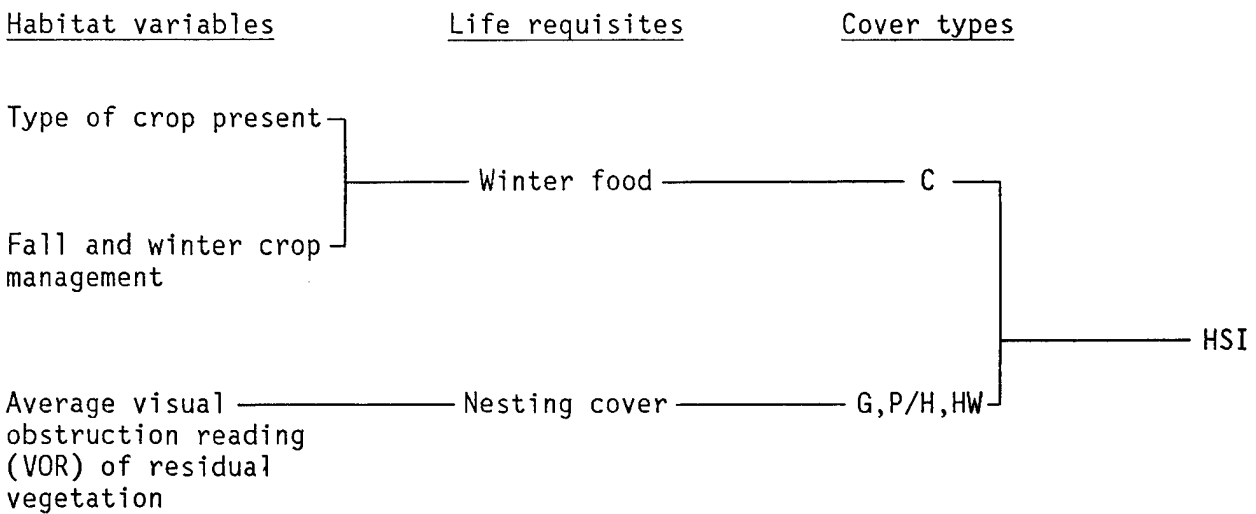

Figure 9. The relationship of habitat variables, life requisites, cover types, and the HSI for the greater prairie-chicken (spatial variables are not shown).

<u>Variable (definition)</u>	<u>Cover types</u>	<u>Suggested techniques</u>
Type of crop present (categories are: corn or sorghum; soybeans; buckwheat or oats; rye, wheat, or other grains; or nongrain crops).	C	Remote sensing (Hays et al. 1981), on-site inspection, local data
Fall and winter crop management (categories are: crop residue hand salvaged or left undisturbed; crop residue lightly tilled; crop residue grazed by livestock; crop residue moldboard plowed, two-pass tilled, or baled, or crop harvested for silage).	C	On-site inspection, local data
Average visual obstruction reading (VOR) of residual vegetation [the average height in decimeters to which herbaceous vegetation from the previous growing season completely obstructs the vision of an object when sighted from a height of 1.0 m (3.3 ft) and a distance of 4.0 m (13.1 ft)].	G,P/H,HW	Robel density pole (Robel et al. 1970a)
Distance between cover types (the distance between cover types providing different life requisites. Used to determine the area of each cover type that is available for prairie-chicken use).	All	See the "HSI determination" section of this model.

Figure 10. Definitions of variables and suggested measurement techniques.

<u>Variable (definition)</u>	<u>Cover types</u>	<u>Suggested techniques</u>
Percent of area providing equivalent optimum winter food [a figure obtained by multiplying the winter food life requisite value in each cover type by the area of each cover type that is available for use by the species and summing these products for all cover types. Fifty percent of an area at an optimum (1.0) value is equivalent to 100% of the area at a 0.5 value].	C	See the "HSI determination" section of this model
Percent of area providing equivalent optimum nesting cover [a figure obtained by multiplying the nesting cover life requisite value in each cover type by the area of each cover type that is available for prairie-chicken use, and summing these products for all cover types providing the nesting life requisite. Fifty percent of an area at an optimum (1.0) value is equivalent to 100% of the area at a 0.5 value].	G,P/H,HW	See the "HSI determination" section of this model.

Figure 10. (concluded).

Model assumptions. The major assumptions in this model are:

1. Winter food and nesting cover are the seasonal limiting factors for greater prairie-chickens; habitat suitability is therefore a function of the quality, quantity, and interspersion of winter food and nesting cover. (If it has been determined that cropland is not a necessary habitat component for a given study area, the winter food element of this assumption will not apply.)
2. Winter food suitability is a function of the relative value of crop types, the abundance of waste grain in the fields after harvest, and the relative area of cropland.
3. Nesting cover suitability is a function of the height and density of residual herbaceous vegetation in the spring and the relative area providing it.
4. The distance between the cover types providing winter food and nesting cover determines the proportion of these cover types that are available for prairie-chicken use.

A potentially important habitat factor that is not considered in this model is open space. Westemeier (pers. comm.) believes that habitats with optimum winter food (SIWF = 1.0) and nesting cover (SINC = 1.0) can still be unsuitable for prairie-chickens if woody cover (e.g., tall trees, hedgerows, and pine windbreaks) is excessive. This factor was not included in the model because of inadequate literature on the subject. However, Westemeier (pers. comm.) hypothesizes that 0.0 to 0.8 km of linear woody vegetation per 2.6 km<sup>2</sup> might be optimum (suitability index = 1.0); 0.9-1.6 km/2.6km<sup>2</sup> might equal a suitability index of 0.75 (i.e., the suitability index decreases by increments of 0.25 as the amount of linear woody vegetation increases by increments of 0.8 km). Blocks of woody vegetation would have to be treated differently. Users of this model should consider this factor in areas where such woody vegetation is common.

Modifications for adjusting model resolution. The model as presented provides a relatively high level of resolution and may require more data than necessary for a particular application, or than is possible to collect due to time or budget constraints. However, the model can be adapted to situations where some lower level of resolution is adequate. When constraints prohibit use of the recommended sampling techniques, any or all suitability indices can be at least approximated using alternative sampling methods, or can be inferred from existing habitat information. For example, it can be less costly and less time consuming to estimate the type of crop present and fall and winter crop management from records kept by agricultural agencies (e.g., U.S.D.A. Agriculture Stabilization and Conservation Service or the Crop and Livestock Reporting Service of the respective State). It may be possible to approximate the average VOR of residual vegetation by considering grazing intensity and hayland management practices. Since grazing reduces the height and density of herbaceous vegetation, an intensively grazed site would be expected to have a low average VOR. The average VOR would be expected to increase as the grazing intensity decreased. The average VOR in haylands mowed during the late summer or in the fall may be inadequate in the spring for nesting cover.

If certain model elements are known to be nonlimiting or are of no concern for a given application, the model can be modified so that only the pertinent elements will have an influence in HSI calculations, and unnecessary sampling is avoided. The following examples show how this can be done by using decreasing levels of resolution. These examples are not the only possible variations; they are only intended to demonstrate ways of adapting the model to the various objectives or constraints of the user.

1. In many situations, it is not possible to sample every stand of vegetation in an entire study area (e.g., very large areas). Such an area can still be assessed with this model by sampling representative portions, and using the data to infer the suitability of the remaining area. In large study areas, it may be possible to identify cropland and cover types providing nesting cover (grassland, pasture and hayland, and herbaceous wetland) from satellite imagery. Representative portions of these cover types can then be selected for sampling. It must be assumed that the habitat variables and spatial variables in sampled portions are representative of those throughout the unsampled portions. Therefore, model use at this level of resolution would be most appropriate in relatively uniform habitats with respect to the condition of habitat variables. The accuracy of this type of model application should increase as the proportion of the study area that is sampled increases. The appropriate sampling level must be determined by the model user, based on the desired reliability of model outputs. The HSI determination procedure can still be used, but the following differences should be noted:
  - (a) Measurements for the distance between cover types need not be measured to other cover types being sampled, but should be measured to the nearest cover type providing the other life requisite whether or not it has been included in the sampling scheme.
  - (b) The relative areas calculated at step 3 in the HSI determination section will represent only the portion of the study area being sampled rather than the entire study area. Therefore, Equations 7 and 8 will replace Equations 5 and 6, respectively.

$$\text{Relative Area (\%)} \text{ for Cover Type A} = \frac{\text{Area of Cover Type A in Sampled Area}}{\text{Total Area of All Sampled Cover Types}} \times 100 \quad (7)$$

$$\text{Relative Area (\%)} \text{ for Cropland Subtype A} = \frac{\text{Area of Subtype A in Sampled Area}}{\text{Total Area of All Sampled Cover Types}} \times 100 \quad (8)$$

- Some applications may be constrained to data collection by remote sensing only. These applications can require a still lower level of resolution from the model since the variables cannot easily be measured with remote sensing. Such an application can estimate what effect the conversion of grassland to cropland has on prairie-chicken habitat, with respect to changes in composition and interspersion of grassland and cropland cover types. This can be done by setting the suitability indices of habitat variables (SIV1, SIV2, and SIV3) to 1.0, and measuring only the spatial variables. The HSI before and after grassland conversion will therefore not be influenced by the condition of individual cover types, but only by the distance between them and their proportional area. The effect of grassland conversion will be shown by the difference in HSI values. Figure 11 shows the various relationships in this model with the outlined area showing the relationships under consideration at this level of resolution.

Because the habitat variables are not measured, winter food (crop quality and availability) is assumed to be optimum, and nesting cover is assumed to be of optimum height and density (i.e., SIV1, SIV2, and SIV3 equal 1.0). This level of resolution should therefore be most accurate when the habitat conditions within cover types are known to be of high quality.

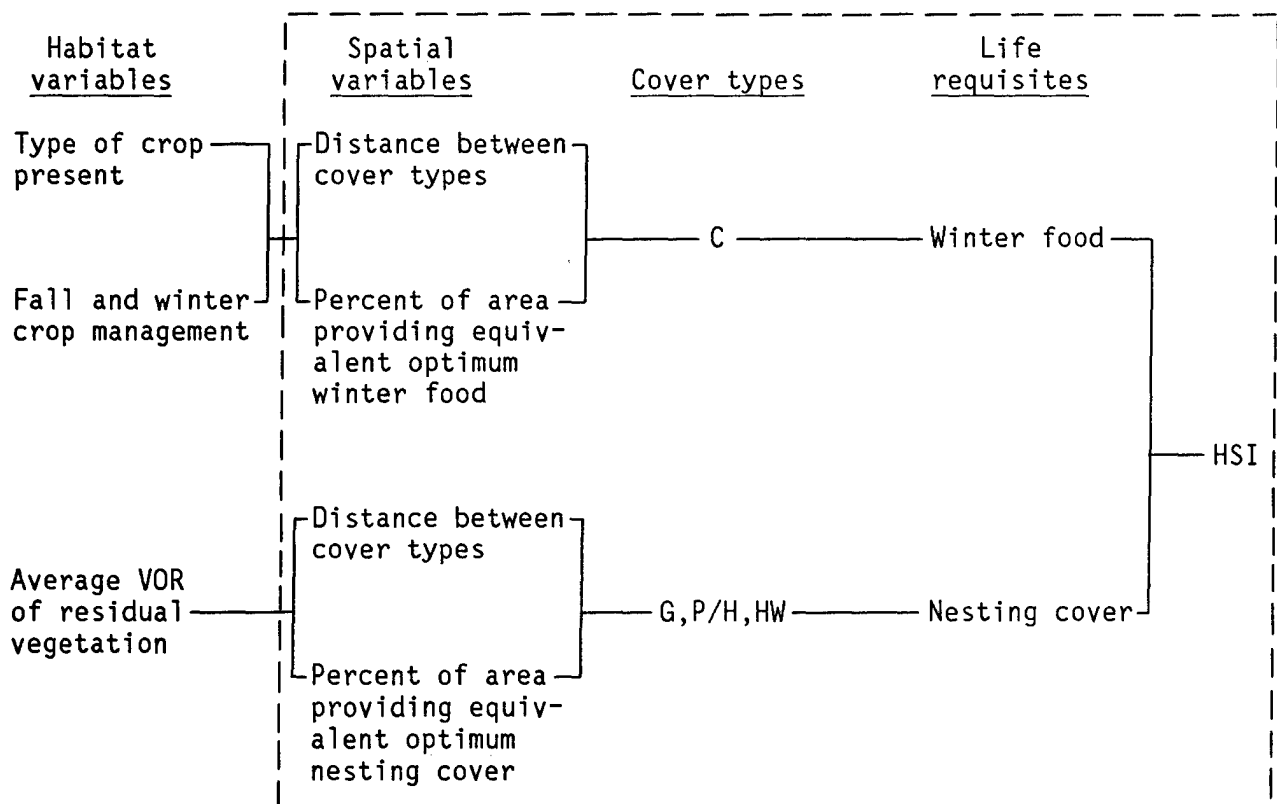

Figure 11. Various relationships in this model with the outlined area showing those under consideration at the level of resolution illustrated in example 2.

- An extremely low level of resolution would consider only the presence and absence of cover types providing life requisites. This may be useful when the user's objective is to simply identify potential greater prairie-chicken habitat such as in large area habitat inventories. Because the winter food life requisite is provided only by cropland, and the nesting cover life requisite is provided only by grassland, pasture and hayland, and herbaceous wetland, prairie-chicken habitat must include cropland and at least one cover type providing nesting cover. Areas possessing both cropland and nesting cover types are assumed to be prairie-chicken habitat and are assigned an HSI value of 1.0. Areas lacking cover types providing one or both life requisites are assumed to be unsuitable for prairie-chickens and are therefore assigned an HSI value of 0.0. Figure 12 shows the various relationships in this model, with the outlined area showing those considered at this level of resolution.

Because the habitat and spatial variables are not measured, it must be assumed that the habitat conditions within all cover types are optimum (i.e., SIV1, SIV2, and SIV3 equal 1.0), and that the distances between and proportions of cover types providing life requisites are optimum (i.e., SIV4, SIV5, and SIV6 equal 1.0).

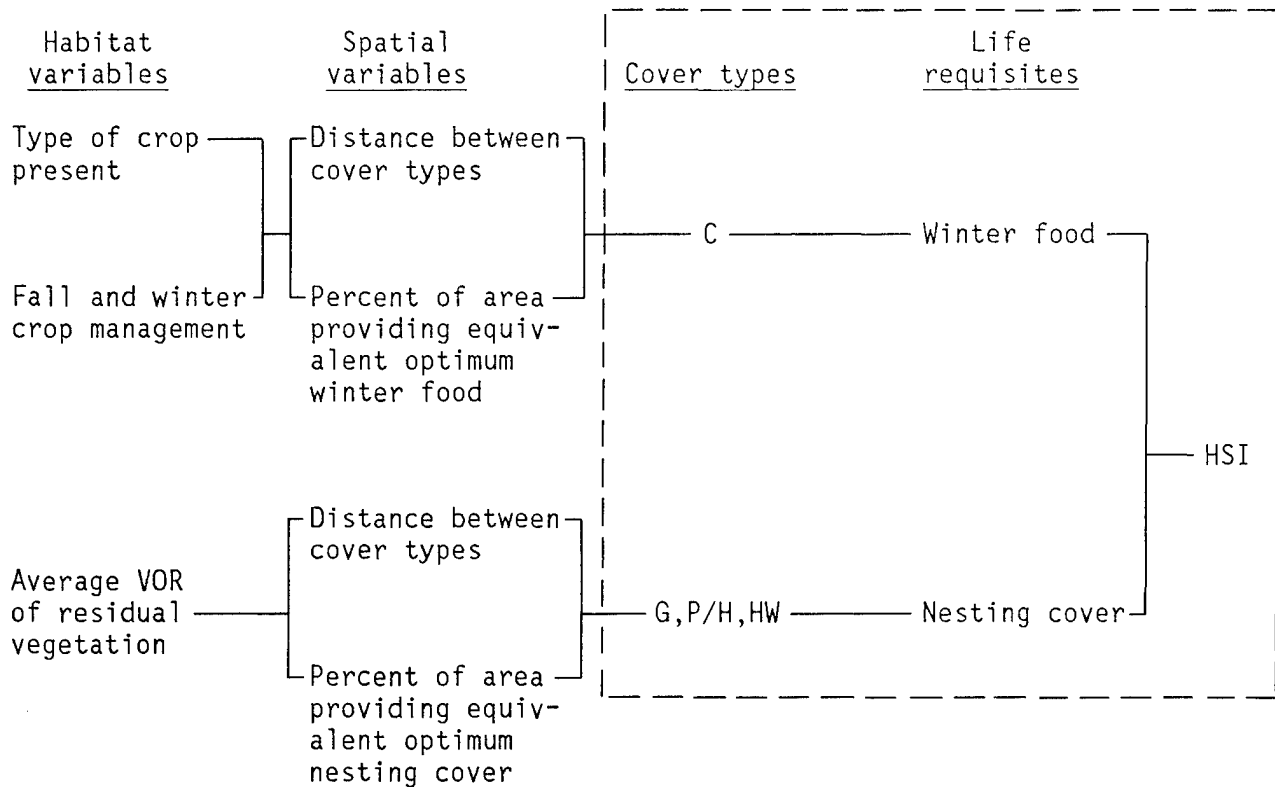

Figure 12. Various relationships in this model with the outlined area showing those under consideration at the level of resolution illustrated in example 3.

## SOURCES OF OTHER MODELS

A method for greater prairie-chicken habitat evaluation has been developed by Evans and Gilbert (1969) for northeastern Colorado. Several key habitat characteristics are evaluated and assigned numerical values. These values are based on the suitability of each characteristic and on the relative importance each has on overall habitat suitability. An overall habitat rating is calculated by summing these values. The Evans and Gilbert (1969) model is based on studies at the periphery of the greater prairie-chicken's range and, therefore, may not be directly applicable to the more central parts of the bird's range.

Another model has been developed for use in cropland and pasture and hayland cover types in Missouri (Urich et al. 1983). The model's structure is similar to that of Evans and Gilbert (1969) but results in an HSI value rather than a summed score. A major difference between the model in Urich et al. (1983) and the one presented here is in the HSI calculation. The former model results in an HSI for each cover type, while this model results in a single HSI for all cover types considered together.

## REFERENCES

- Aldrich, J. W. 1963. Geographic orientation of American Tetraonidae. *J. Wildl. Manage.* 27(4):529-545.
- Ammann, G. A. 1957. The prairie grouse of Michigan. Michigan Dept. Conserv. Tech. Bull. 200 pp.
- Baker, M. F. 1953. Prairie chickens of Kansas. Univ. Kansas Mus. Nat. Hist. and Biol. Surv. Kansas, Misc. Publ. 5. 68 pp.
- Baldassarre, G. A., R. J. White, E. E. Quinlan, and E. G. Bolen. 1983. Dynamics and quality of waste corn available to post breeding waterfowl in Texas. *Wildl. Soc. Bull.* 11(1):25-31.
- Barnes, W. B. 1952. Prairie chicken booming grounds in Indiana. *Indiana Audubon Q.* 30(1):7-9.
- Buhnerkempe, J. E., W. R. Edwards, D. R. Vance, and R. L. Westemeier. 1984. Effects of residual vegetation on prairie-chicken nest placement and success. *Wildl. Soc. Bull.* 12(4):382-386.
- Drobney, R. D., and R. D. Sparrowe. 1977. Land use relationships and movements of greater prairie chickens in Missouri. *Trans. Missouri Acad. Sci.* 10-11:146-160.
- Edminster, F. C. 1954. American game birds of field and forest. Charles Scribner's Sons, NY. 490 pp.
- Evans, K. E. 1968. Characteristics and habitat requirements of the greater prairie chicken and sharp-tailed grouse - a review of the literature. U.S. For. Serv. Conserv. Res. Rep. 12. 32 pp.



- Evans, K. E., and D. L. Gilbert. 1969. A method for evaluating greater prairie chickens habitat in Colorado. *J. Wildl. Manage.* 33(3):643-649.
- Frederick, R. B., E. E. Klaas, G. A. Baldassarre, and K. J. Reinecke. 1984. A method for sampling waste corn. *J. Wildl. Manage.* 48(1):298-303.
- Hamerstrom, F. N., Jr. 1939. A study of Wisconsin prairie chicken and sharp-tailed grouse. *Wilson Bull.* 51(2):105-120.
- Hamerstrom, F. N., Jr., and F. Hamerstrom. 1949. Daily and seasonal movements of Wisconsin prairie chickens. *Auk* 66(4):313-337.
- Hamerstrom, F. N., Jr., F. Hopkins, and A. J. Rinzel. 1941. An experimental study of browse as a winter diet for prairie chickens. *Wilson Bull.* 53(3):185-195.
- Hamerstrom, F. N., Jr., O. H. Mattson, and F. Hamerstrom. 1957. A guide to prairie chicken management. Wisconsin Conserv. Dept. Tech. Bull. 15. 128 pp.
- Hays, R. L., C. Summers, and W. Seitz. 1981. Estimating wildlife habitat variables. U.S. Fish Wildl. Serv. FWS/OBS-81/47. 111 pp.
- Horak, G. J. 1971. Population dynamics of prairie chicken in grassland and cropland areas. P-R Proj. W-23-R, Job D-3, Kansas For., Fish and Game Comm. 98 pp.
- Illinois Natural History Survey. 1984. Prairie chicken management - cycles, densities, and thresholds. Illinois Nat. Hist. Surv. Rep. 235. 4 pp.
- Janson, R. G. 1953. Prairie grouse habitat survey, 1950-1952. P-R Completion Rep., Proj. W-17-R-7, South Dakota Dept. Game, Fish and Parks. 9 pp.
- Johnsgard, P. A. 1973. Grouse and quails of North America. Univ. Nebraska Press, Lincoln. 553 pp.
- \_\_\_\_\_. 1983. Grouse of the world. Univ. Nebraska Press, Lincoln 413 pp.
- Jones, R. E. 1963. Identification and analysis of lesser and greater prairie chicken habitat. *J. Wildl. Manage.* 27(4):757-778.
- Kirsch, L. M. 1974. Habitat management considerations for prairie chickens. *Wildl. Soc. Bull.* 2(3):124-129.
- Kirsch, L. M., A. T. Klett, and H. W. Miller. 1973. Land use and prairie grouse population relationships in North Dakota. *J. Wildl. Manage.* 37(4):449-453.
- Kobriger, G. D. 1965. Status, movements, habitats, and foods of prairie grouse on a sandhills refuge. *J. Wildl. Manage.* 29(4):788-800.

- Kohn, S. C. 1976. Sharp-tailed grouse nesting and brooding habitat in southwestern North Dakota. M.S. Thesis, South Dakota State Univ., Brookings. 41 pp.
- Korschgen, L. J. 1962. Food habits of greater prairie chickens in Missouri. *Am. Midl. Nat.* 68:307-318.
- Lehmann, V. W. 1941. Attwater's prairie chicken: its life history and management. *U.S. Fish and Wildl. Serv. N. Am. Fauna* 57. 65 pp.
- Maertens, G. H. 1973. The status of the prairie chicken in Minnesota: habitat management practices. Pages 89-91 *in* W. D. Svedarsky, ed. *Proc. Conf. on the Prairie Chicken in Minnesota*. Univ. Minnesota, Crookston.
- McClure, H. E. 1943. A study of the distribution, food, nesting, and mortality of the common upland game birds in Nebraska. *Pittman-Robertson Q.* 3(3):137-139.
- Moen, A. N. 1983. *Agriculture and wildlife management*. CornerBrook Press, Lansing, NY. 367 pp.
- Mohler, L. L. 1952. Fall and winter habits of prairie chickens in southwest Nebraska. *J. Wildl. Manage.* 16(1):9-23.
- Ordendurff, C. F. 1941. The first wildlife inventory of Nebraska shelterbelts. *Nebraska Bird Rev.* 9:7-8.
- Patterson, M. L. 1973. The status of the prairie chicken in Minnesota: population and habitat trends. Pages 80-85 *in* W. D. Svedarsky, ed. *Proc. Conf. on the Prairie Chicken in Minnesota*. Univ. Minnesota, Crookston.
- Poelker, R. J., and I. O. Buss. 1972. Habitat improvement - the way to higher wildlife populations in southeast Washington. *N.W. Sci.* 46(1):25-31.
- Robel, R. J., J. N. Briggs, A. D. Dayton, and L. C. Hulbert. 1970a. Relationships between visual obstruction measurements and the weight of grassland vegetation. *J. Range Manage.* 23(4):295-297.
- Robel, R. J., J. N. Briggs, J. J. Cebula, N. J. Silvy, C. E. Viers, and P. G. Watt. 1970b. Greater prairie chicken ranges, movements, and habitat usage in Kansas. *J. Wildl. Manage.* 34(2):286-306.
- Schmidt, F. J. W. 1936. Winter food of the sharp-tailed grouse and pinnated grouse in Wisconsin. *Wilson Bull.* 48:186-203.
- Schwartz, C. W. 1945. The ecology of the prairie chicken in Missouri. *Univ. Missouri Studies* 20(1):1-99.
- Skinner, R. M. 1974. Grassland use patterns and prairie bird populations in Missouri. M.S. Thesis, Univ. Missouri, Columbia. 52 pp.

- Svedarsky, W. D. 1979. Spring and summer ecology of female greater prairie chickens in northwestern Minnesota. Ph.D. Diss., Univ. North Dakota, Grand Forks. 166 pp.
- Toney, T. E. 1980. Foods of prairie chickens on managed native prairie. Pages 81-84 in P. A. Vohs, Jr. and F. L. Knopf, eds. Proc. Prairie Grouse Symp., Oklahoma State Univ., Stillwater.
- Trippensee, R. E. 1948. Wildlife Management, Vol. I. McGraw Hill Book Co., NY. 479 pp.
- Urich, D. L., J. P. Graham, and C. C. Cook (compilers). 1983. A handbook for habitat evaluation in Missouri. Missouri Dept. Conserv., U.S. Soil Conserv. Serv. (Columbia), and U.S. Fish Wildl. Serv. (Columbia). 148 pp.
- U.S. Fish and Wildlife Service. 1981a. Standards for the development of habitat suitability index models. 103 ESM. U.S. Fish Wildl. Serv. Div. Ecol. Serv. n.p.
- \_\_\_\_\_. 1981b. The Platte River ecology study. U.S. Fish Wildl. Serv. Special Res. Rep., Northern Prairie Wildl. Res. Center, Jamestown, North Dakota. 187 pp.
- Walker, R. D. 1981. Residue management to reduce soil erosion. Pages 36-40 in Conservation tillage: regional seminar 1981. Univ. Illinois, Urbana-Champaign.
- Warner, R. E., S. P. Havera, and L. M. David. 1985. Effects of autumn tillage systems on corn and soybean harvest residues in Illinois. J. Wildl. Manage. 49(1):185-190.
- Westemeier, R. L. 1973. Prescribed burning in grassland management for prairie chickens in Illinois. Proc. Annu. Tall Timbers Fire Ecol. Conf. 12:317-338.
- \_\_\_\_\_. 1980. Greater prairie chicken status and management -- 1968-1979. Pages 8-17 in P. A. Vohs, Jr. and F. L. Knopf, eds. Proc. Prairie Grouse Symp. Oklahoma State Univ., Stillwater.
- Westemeier, R. L., and J. E. Buhnerkempe. 1983. Responses of nesting wildlife to prairie grass management on prairie chicken sanctuaries in Illinois. Proc. North Am. Prairie Conf. 8: 39-46.
- Yeatter, R. E. 1943. The prairie chicken in Illinois. Illinois Nat. Hist. Surv. Bull. 22(4):377-416.

<b>REPORT DOCUMENTATION PAGE</b>	<b>1. REPORT NO.</b> Biological Report 82(10.102)	<b>2.</b>	<b>3. Recipient's Accession No.</b>
<b>4. Title and Subtitle</b> Habitat Suitability Index Models: Greater Prairie-Chicken (Multiple Levels of Resolution)		<b>5. Report Date</b> August 1985	
<b>7. Author(s)</b> Bart L. Prose		<b>6.</b>	
<b>9. Performing Organization Name and Address</b> Western Energy and Land Use Team U.S. Fish and Wildlife Service Drake Creekside Building One 2627 Redwing Road Fort Collins, CO 80526-2899		<b>8. Performing Organization Rept. No.</b>	
<b>12. Sponsoring Organization Name and Address</b> Western Energy and Land Use Team Division of Biological Services Research and Development Fish and Wildlife Service Department of the Interior, Washington, DC 20240		<b>10. Project/Task/Work Unit No.</b>	
		<b>11. Contract(C) or Grant(G) No.</b> (C) (G)	
<b>15. Supplementary Notes</b> The Biological Report series was initiated in October 1984 to replace the FWS/OBS series published since 1976. The report number assigned to this model follows consecutively from the Habitat Suitability Index models published as FWS/OBS-82/10., now numbered as Biological Report 82(10. ).		<b>13. Type of Report &amp; Period Covered</b>	
<b>16. Abstract (Limit: 200 words)</b>		<b>14.</b>	
<p>A review and synthesis of existing information were used to develop a Habitat Suitability Index (HSI) model for the greater prairie-chicken (<u>Tympanuchus cupido pinnatus</u>). The model consolidates habitat use information into a framework appropriate for field application, and is scaled to produce an index between 0.0 (unsuitable habitat) and 1.0 (optimum habitat). HSI models are designed to be used with Habitat Evaluation Procedures previously developed by the U.S. Fish and Wildlife Service.</p>			
<b>17. Document Analysis a. Descriptors</b>			
Birds Wildlife Habitability Mathematical models			
<b>b. Identifiers/Open-Ended Terms</b>			
Greater prairie-chicken <u>Tympanuchus cupido pinnatus</u> Habitat suitability			
<b>c. COSATI Field/Group</b>			
<b>18. Availability Statement</b>		<b>19. Security Class (This Report)</b>	<b>21. No. of Pages</b>
Release unlimited		Unclassified	33
		<b>20. Security Class (This Page)</b>	<b>22. Price</b>
		Unclassified	

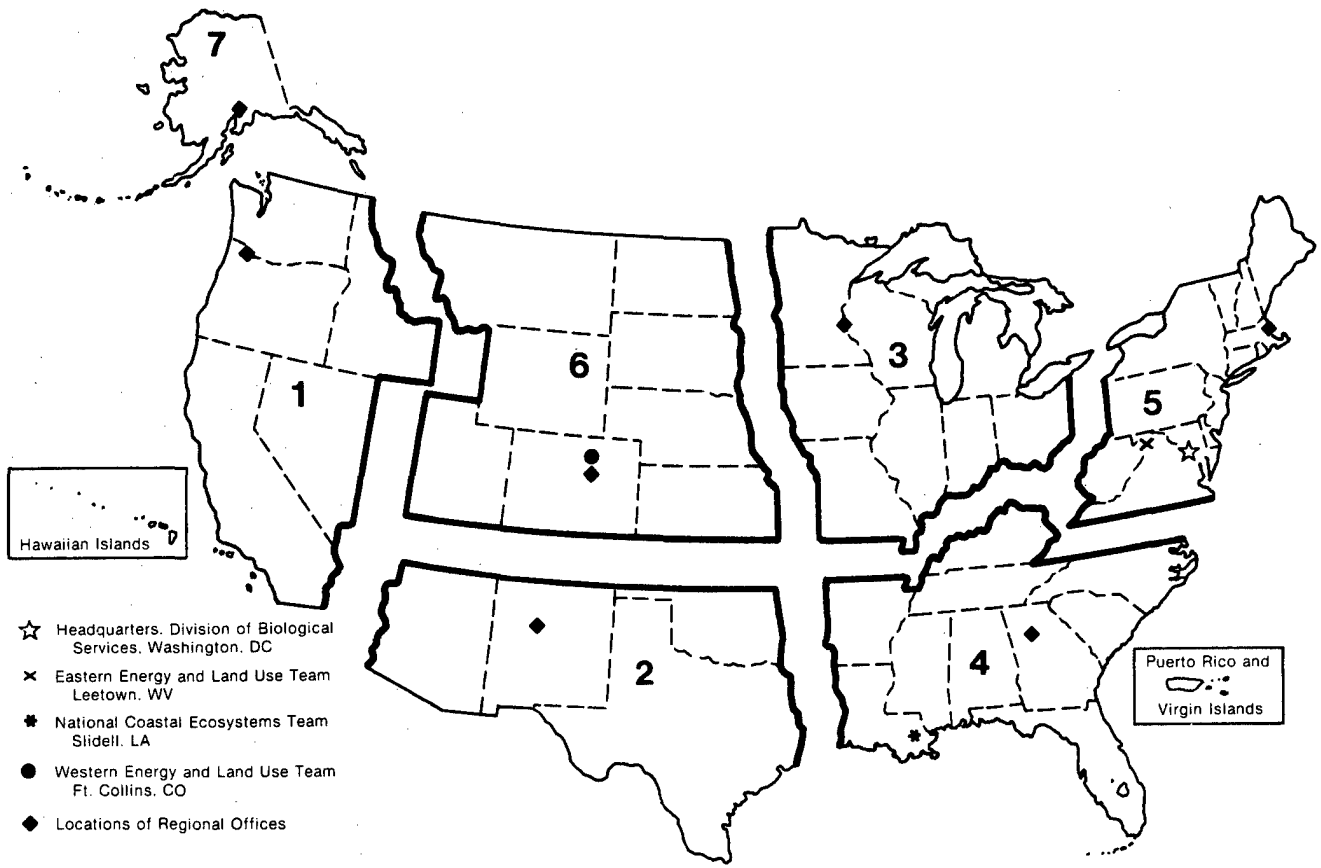

**REGION 1**

Regional Director  
 U.S. Fish and Wildlife Service  
 Lloyd Five Hundred Building, Suite 1692  
 500 N.E. Multnomah Street  
 Portland, Oregon 97232

**REGION 2**

Regional Director  
 U.S. Fish and Wildlife Service  
 P.O. Box 1306  
 Albuquerque, New Mexico 87103

**REGION 3**

Regional Director  
 U.S. Fish and Wildlife Service  
 Federal Building, Fort Snelling  
 Twin Cities, Minnesota 55111

**REGION 4**

Regional Director  
 U.S. Fish and Wildlife Service  
 Richard B. Russell Building  
 75 Spring Street, S.W.  
 Atlanta, Georgia 30303

**REGION 5**

Regional Director  
 U.S. Fish and Wildlife Service  
 One Gateway Center  
 Newton Corner, Massachusetts 02158

**REGION 6**

Regional Director  
 U.S. Fish and Wildlife Service  
 P.O. Box 25486  
 Denver Federal Center  
 Denver, Colorado 80225

**REGION 7**

Regional Director  
 U.S. Fish and Wildlife Service  
 1011 E. Tudor Road  
 Anchorage, Alaska 99503



**DEPARTMENT OF THE INTERIOR**  
**U.S. FISH AND WILDLIFE SERVICE**



As the Nation's principal conservation agency, the Department of the Interior has responsibility for most of our nationally owned public lands and natural resources. This includes fostering the wisest use of our land and water resources, protecting our fish and wildlife, preserving the environmental and cultural values of our national parks and historical places, and providing for the enjoyment of life through outdoor recreation. The Department assesses our energy and mineral resources and works to assure that their development is in the best interests of all our people. The Department also has a major responsibility for American Indian reservation communities and for people who live in island territories under U.S. administration.