

GENETIC CHARACTERIZATION OF BROWN BEARS OF THE KODIAK ARCHIPELAGO

Sandra L. Talbot¹, Judy R. Gust¹, George K. Sage¹, Anthony Fischbach¹, Kristin Amstrup¹,
William Leacock² and Larry Van Daele³

¹*U. S. Geological Survey, Alaska Science Center, 1011 East Tudor Road, MS 701, Anchorage, AK 99503*

²*U. S. Fish and Wildlife Service, Yukon Delta National Wildlife Refuge, P.O. Box 346,
Bethel, AK 99559*

³*Alaska Department of Fish and Game, Division of Wildlife Conservation, 211 Mission Rd.,
Kodiak, AK 99615*

Final Report To:

Kodiak National Wildlife Refuge
U. S. Fish and Wildlife Service
1390 Buskin River Road
Kodiak, Alaska 99615

2 February 2006

Table of Contents

Executive Summary	3
Technical Abstract	6
Materials and Methods	11
Sample Collection and Extraction	11
Genotyping and Sequencing	11
Linkage and Hardy Weinberg Equilibrium	12
Genetic Diversity	12
Genetic Differentiation	13
Population Relationships	13
Detection of Bottlenecks	13
Marker Resolution for Genetic Tagging Studies.	14
Population Demographics	14
Phylogeographic Analyses of MtDNA Sequence	14
Analysis of MHC DQB and DQA Sequences	15
Project Management and Acknowledgements	15
Results	16
Data Collection	16
Matching Samples	16
Linkage and Hardy Weinberg Equilibrium	16
Genetic Diversity	17
Sequence Diversity	17
Genetic Differentiation	17
Population Relationships	18
Contemporary and Historical Population Demographics	19
Marker Resolution for Genetic Tagging Studies	19
Phylogeographic Analyses	19
MHC DQA and DQB Analyses	20
Discussion	22
Genetic Diversity and Substructuring at Neutral DNA Markers	22
Phylogenetic Relationships	25
Major Histocompatibility Genes: DQB1 Exon 2	27
Conservation Implications	29
Literature Cited	32
Figure Legends	43

Executive Summary

Studies conducted during the last decade demonstrate that brown bears of the Aliulik Peninsula on Kodiak Island exhibit the lowest levels of genetic diversity at nuclear microsatellite loci of any brown bear population in North America. It is unclear whether the low levels of genetic variation observed at these neutral nuclear markers in bears of the Aliulik Peninsula are representative of Kodiak Island and the Kodiak Archipelago as a whole, and, if so, whether the low genetic variation observed in the neutral markers reflects low variability in functional markers involved in fitness. Furthermore, published and unpublished sequence data from the cytochrome *b* gene and the control region of the maternally-inherited mitochondrial DNA (mtDNA) from bears across a broader geographic region in the Kodiak Archipelago suggest that levels of genetic variation at the mtDNA genome are higher than those reported from several populations on mainland Alaska (the Kenai Peninsula and Izembek National Wildlife Refuge). This study was initiated to address questions regarding levels of diversity in Kodiak Archipelago populations at genetic markers that differ in mode of inheritance and rate of evolution, to provide an improved basis for conservation of the Kodiak brown bear, and to respond to objectives of the Kodiak National Wildlife Refuge to “...*assess genetic diversity of the Kodiak brown bear so as to understand gene flow between the southern and northern Archipelago, the vulnerability of Kodiak brown bears to wildlife diseases, environmental stresses, and parameters of population viability*” (Kodiak NWR 2002 Draft Comprehensive Conservation Plan Revision, 2004).

We examined genetic characteristics of brown bears of Kodiak and Afognak Islands using 14 variable nuclear microsatellite loci and nucleotide sequence information from the hypervariable I domain of the mtDNA control region, across a broader geographic range than previously studied. We also collected data from the class II DQA and DQB loci of the brown bear major histocompatibility complex (MHC), to examine levels of variation at this important immunology-mediating supergene. These data were evaluated to address the following questions: 1) are earlier findings of extremely low levels of variation at nuclear microsatellite loci representative of the Kodiak Archipelago populations as a whole? 2) Is the level and type of variation at the maternally inherited mtDNA lower, or similar to, levels found in other populations in Alaska? 3) Is there concordance between low levels of genetic variation observed

at neutral nuclear markers with levels of variation observed at functional genes? 4) What is the connectivity between populations on Afognak and those on Kodiak Island? 5) Is there population substructuring within Kodiak and Afognak islands? 6) What is the phylogeographic relationship among bears of the Kodiak Archipelago and those on nearby mainland Alaska and other western Beringian populations? 7) Do the genetic markers employed provide adequate resolution to use in future genetic tagging studies?

The results of this research demonstrate that the earlier findings of extremely low levels of genetic variation at neutral nuclear microsatellite markers in the Aliukik Peninsula are representative of the Kodiak Archipelago as a whole. Comparative data from the class II exon 2 DQB of the MHC suggest the low levels of genetic variation observed at neutral nuclear markers on the Kodiak Archipelago reflect low levels of variation at nuclear functional genes involved in fitness. Higher levels of variation at the maternally-inherited mtDNA loci are observed within the Kodiak Archipelago populations relative to some other Alaskan populations. However, the type of site substitutions observed in mtDNA sequence data comprised largely of insertions/deletions in “mutational hotspots”¹ associated with the 5’ thymine repeat region. Haplotypes defined using variation at this mutational hotspot appear to be geographically segregated across the Kodiak Archipelago. This is similar to variation in maternal lineages observed and used to examine microgeographic structuring resulting from female philopatry in brown bear populations on the island of Hokkaido, Japan. Researchers suspect that the Hokkaido population has been isolated from mainland populations since the end of the last Pleistocene glaciation, approximately 12,000 BP. Our genetic evidence suggests a similar pattern of colonization, establishment, and isolation, for brown bears of the Kodiak Archipelago. Nevertheless, Kodiak Archipelago bears share closest evolutionary relationships with populations in western Alaska, the Alaska Peninsula, and Siberia.

¹“mutational hotspots” are sites that evolve at a rate much faster than average. There are several “hotspot” regions within the mitochondrial control region.

Despite evidence of substructuring² of maternal lineages within the larger population on Kodiak Island, genetic evidence from nuclear microsatellite loci suggests bears of Kodiak Island comprise a single interbreeding population; the same is true for Afognak Island bears. This pattern is consistent with female philopatry and largely male-mediated gene flow, even at the microgeographic scale. However, gene flow between Kodiak and Afognak is small enough that Afognak comprises a genetically distinguishable population. We found that the levels of genetic diversity at loci adequate for use in genetic tagging in other populations of brown bears in Alaska are insufficiently variable for similar use in Kodiak Archipelago populations. Furthermore, it is unlikely that the use of additional variable genetic markers would improve resolution sufficient to support a robust study of population estimation using genetic tagging. The most variable gene known to occur in terrestrial vertebrates, the class II DQB1 exon 2 locus, is essentially monomorphic within the archipelago's two brown bear populations.

Low variation at the DQB1 exon 2 MHC class II locus, which plays an essential role in the recognition of, and response to, parasites (bacterial, protozoan and other parasites and pathogens), has been documented in other natural populations that have undergone recent bottlenecks. However, genetic tests for recent (from 2 – 20 generations) bottlenecks in the Kodiak Archipelago populations did not uncover a signature of a bottleneck in either the Kodiak Island or Afognak populations. Other tests, however, suggest the Kodiak Archipelago populations may be characterized by longer term (up to 100 generations) low effective population size³.

Knowledge of the relationship between MHC variation and resistance to parasites in a given individual, population or species is limited for brown bears. However, there are several

²substructuring here refers to a phenomenon whereby a population, by definition considered to be comprised of a single population of randomly interbreeding individuals, is actually comprised of two or more smaller "subpopulations" that are distinct. In this case, substructuring is observed within the female lineages on Kodiak Island, assessed using data from the maternally-inherited mitochondrial DNA.

³effective population size is the number of individuals in a population who contribute offspring to the next generation. In practice, effective population size is usually lower than the ecologically-observed population size.

well-documented cases in other species in which specific MHC haplotypes or genotypes confer resistance to parasites. On the other hand, researchers have also documented cases in which healthy natural populations are characterized by low genetic variability at MHC loci, so it is unclear whether this finding of low variation at a MHC locus necessarily reflects an unhealthy population. Presently, the archipelago's bear populations appear healthy and viable; they show no apparent genetic signature of inbreeding or phenotypic signs of inbreeding depression. Nevertheless, continued vigilance may be warranted. Because Kodiak brown bears exhibit extremely low variability at the MHC class II DQBI exon 2 gene, they may have reduced capacity to thwart novel or introduced pathogens.

Technical Abstract

In previous studies, bears of the Aliulik Peninsula on Kodiak Island were found to exhibit the lowest levels of genetic diversity at neutral nuclear microsatellite loci of any brown bear population in North America. It was unclear, however, whether the observed low genetic diversity was representative of Kodiak Archipelago as a whole, and whether this low variation in neutral markers would also be reflected in functional genes, specifically the immune-regulating major histocompatibility complex (MHC). Levels of population substructuring within the Archipelago are also unknown. We used three sets of genetic markers to characterize brown bears of Kodiak and Afognak Islands of the Kodiak Archipelago: fragment analysis of 14 variable nuclear microsatellite loci, sequence from the nuclear class II exon 2 DQB1 of the MHC (MHC DQB), and sequence from the mtDNA control region. Our data extend the earlier finding of extremely low levels of genetic variation at neutral nuclear microsatellite markers in the Aliulik Peninsula as being representative of the Kodiak Archipelago as a whole.

Comparative data from the nuclear functional gene involved in the immune response, MHC DQB, corresponds with the low levels of genetic variation observed in neutral nuclear markers. Divergence at the MHC DQB locus from mainland Alaskan bear populations also suggests that

Kodiak Archipelago bears have experienced different selection pressures since isolation. No evidence of substructuring within the Kodiak or Afognak island populations was observed in the nuclear loci. The two island populations, however, were found to be significantly differentiated from each other based on variance of nuclear microsatellite allele and mtDNA control region haplotype frequency. Variation observed at the maternally-inherited mitochondrial DNA (mtDNA) control region is lower than many, but not all, populations of brown bears elsewhere in Alaska. However, most of the observed variation in the Archipelago is found in “mutational hotspots” which has likely arisen since the isolation of brown bears on Kodiak Island subsequent to the recession of ice sheets at the end of the last Pleistocene glaciation. The variation in the mtDNA control region appears to be useful in examining segregation of maternal lineages in the Kodiak Island population. However, the low levels of variation observed at the nuclear markers likely preclude their use as “genetic tags” for individual identification.

The Kodiak National Wildlife Refuge (Kodiak NWR) supports a large population of brown bears (*Ursus arctos* L.), which are distributed throughout the Kodiak Archipelago, a group of islands that lie at the western border of the Gulf of Alaska. Extrapolation from studies conducted from five areas on Kodiak Island to comparable habitat suggest approximately 2,980 brown bears inhabit the entire Archipelago, with densities averaging 0.24 bears/km² (Alaska Department of Fish and Game 2002). Highest densities occur at Karluk Lake in southwestern Kodiak Island (0.42 bears/km²), and lowest on small, isolated islands (0.04 bears/km²) (Barnes and Smith 1998). Brown bears of the Kodiak Archipelago are generally recognized as an endemic subspecies (*U. a. middendorffi*) based on morphological and ecological characteristics (Rausch 1963, Kurtén 1973, and Hall 1984). However, phylogenetic and phylogeographic analyses based on extensive mitochondrial DNA (mtDNA) nucleotide sequence data (Talbot and Shields 1996a, b; Waits et al. 1998) have not supported the status of these bears as a unique taxonomic unit when placed within a comparative framework with other populations of brown bears in Alaska. Nevertheless, because bears of the Kodiak Archipelago are morphologically unique, hold a

special symbolic value for the public, and because genetic studies of brown bears of the Aliulik Peninsula, Kodiak Island (Paetkau et al. 1998b) have revealed the population on Kodiak has less variability at neutral nuclear loci than mainland Alaskan populations, conservation efforts continue to consider the Kodiak brown bear as a distinct subspecies or population of special conservation value (Miller and Schoen 1999).

The Kodiak brown bear is thought to have been isolated from mainland brown bears for approximately 12,000 years and has survived several periods of intense ecological disruption during the EuroAmerican settlement period, including reduction in salmon food supply, unregulated harvest, and commercial fur trade activities (Van Daele 2003). Isolation from other brown bear populations on mainland Alaska, coupled with cyclic ecological disruption, may have left the brown bears on Kodiak Island with low levels of genetic diversity. This is supported by the observation that brown bears from the Aliulik Peninsula on Kodiak Island are characterized by the lowest levels of genetic diversity at nuclear microsatellite loci recorded for any brown bear population in North America (Paetkau et al. 1998b). However, preliminary analysis of Kodiak brown bear mtDNA control region sequence information from across Kodiak has uncovered higher haplotype diversity than found on the Kenai Peninsula (Talbot, unpublished data; Jackson et al. 2005).

It is not known whether the populations inhabiting the Kodiak Archipelago are genetically substructured, either within Kodiak Island, or between Kodiak Island and other islands comprising the Archipelago, such as Afognak Island. Kodiak Island, encompassing an area of 9,375 km², affords high quality brown bear habitat. Inland habitat on Kodiak Island is contiguous and mostly intact, human activity is generally restricted to isolated areas along the coast, extent of roads is limited (< 160 km total); and bear conservation is a high priority (Alaska Department of Fish and Game 2003). The only large-scale disruption to inland habitat, development and operation of the Terror Lake hydroelectric project, minimally impacted bears (Van Daele 2003).

Afognak Island, encompassing an area of 180 km², apparently once supported an array of non-forested habitats similar in composition to those found on Kodiak Island (Tae 1997). However, habitat composition on Afognak has changed substantially since Sitkas (*Picea sitchensis*) established there, probably about 1,000 years ago (Tae 1997). Presently about 48% of the area of Afognak Island and 3% of the area of Kodiak Island are dominated by spruce

vegetation types (Fleming and Spencer 2004). In addition, during the past 25 years, Afognak Island has experienced considerable habitat alteration as a result of commercial logging, mostly on private forest lands outside of Refuge boundaries (USFWS 2004). Because monitoring the bear population on Afognak is difficult, it is not known whether these practices have impacted brown bear populations on the island. It is presumed that logging practices, thus far, have had minimal adverse impact on brown bears, due to Afognak's healthy salmon runs, good berry and grass production, low levels of direct human-bear interaction and substantial limitations to access of privately-owned logging roads (Alaska Department of Fish and Game 2002, Van Daele 2003).

Levels of gene flow between brown bear populations occupying the islands of the Kodiak Archipelago are uncharacterized, and it is not clear whether the Afognak population receives augmentation from Kodiak Island populations. The single genetic study including data from brown bears of Afognak Island (Talbot and Shields 1996a) demonstrates these bears share mitochondrial DNA cytochrome *b* haplotypes with bears of Kodiak Island. However, the addition of nucleotide sequence information from the more variable mtDNA control region collected from a small number of bears on Afognak Island ($n = 6$) afforded increased resolution over cytochrome *b* sequences alone, and at least one unique haplotype has been observed on Afognak Island (Talbot, unpublished data). It is unknown whether the low levels of genetic diversity observed at nuclear microsatellite markers on the Aliulik Peninsula on Kodiak Island (Paetkau et al. 1998b) are also characteristic of Afognak Island populations.

Restricted genetic diversity at neutral loci may reflect lower levels of diversity in the population at functional loci and, therefore, decreased fitness (Hansson and Westerberg 2002). This has raised concern over the Kodiak brown bear's ability to resist novel pathogens and other sources of environmental stress, such as habitat fragmentation, although the brown bear population on the Kodiak Refuge is considered to be healthy and its habitat adequately protected (USFWS 2004). Nevertheless, the presence of domestic cattle, small-scale livestock operations, and game ranches in the Archipelago may increase the likelihood of exposure to novel epizootic pathogens.

Currently, there are four major ranching operations on the Kodiak Archipelago. While two of these raise cattle, the other two raise a combination of cattle and semi-domesticated game, such as elk and bison. There are also numerous small-scale livestock operations run wholly on rural private lands (Tom Lance, National Conservation Service, pers. comm. 29 Sept. 2005).

Most of these livestock and game operations are along the Kodiak Island road system, but at least one is located on a remote island. Although statewide prohibitions forbid the importation of new domestic elk, and although ongoing surveillance by Alaska Department of Fish and Game personnel has uncovered no evidence for introduced diseases as a result of these domestic game operations (ADF&G 2002), history has demonstrated that human protection against wildlife epizootics is often unsuccessful without high levels of philosophical and economic commitment (see Woodson and Rossiter 1994, Wobeser 2002 and references therein). It is, therefore, sensible to assess the ability of the isolated brown bear populations on the Kodiak Archipelago to respond to novel or introduced epizootics. Determining levels of genetic diversity at other neutral, as well as functional, genes over a larger geographic range within the Kodiak Archipelago will allow Refuge staff to apply appropriate management options and frame the appropriate level of management concern.

The major histocompatibility complex (MHC) is a fundamental part of the immune system in vertebrates (Edwards and Hedrick 1998). High variability in many MHC genes is thought to play an essential role in the recognition of (and response to) parasites (viral, bacterial, protozoan and other parasites and pathogens). Documenting the levels of MHC variation in natural populations should provide insight into its potential resistance or susceptibility to various parasites. Although demonstrating the connection between MHC variation and resistance to parasites in a given population or species is difficult, there are several well-documented cases in which specific MHC haplotypes or genotypes provide resistance to certain parasites (Briles et al. 1977, Hill et al. 1991, Xu et al. 1993, Thursz et al. 1997, Paterson et al. 1998, Carrington et al. 1999). One of the complications in demonstrating association between levels of variation and susceptibility to disease is that the MHC is a multi-gene family, making it difficult to separate the effects of specific alleles from the background genotypes, or even to determine which MHC sequence is allelic and which are from other loci. Nevertheless, we have identified what we believe are alleles of the class II DQB1 exon 2 MHC gene in Alaskan brown bears (Talbot, unpublished data), a first step in testing such associations.

Here we examine genetic characteristics of brown bears of Kodiak and Afognak islands, using 14 variable nuclear microsatellite loci and nucleotide sequence information including the hypervariable domain I of the mtDNA control region (Wakely 1993). Because these markers, or a subset of them, have been used to characterize brown bears of the Kenai Peninsula (Jackson et

al. 2005), Katmai National Park, Seward Peninsula, and nine other populations in Alaska (Talbot, unpublished data), we compared levels of genetic diversity and relationships among populations when possible. In addition, we obtained preliminary comparative information from class II DQA and DQB genes of the brown bear MHC, to examine levels of variation at this important immunology-mediating supergene. These data were used to answer the following questions: 1) are earlier findings of extremely low levels of variability at nuclear (biparentally-inherited) microsatellite loci from a small geographic area (Paetkau et al. 1998b) representative of Kodiak Archipelago populations as a whole? 2) Is the level and type of variation at the maternally-inherited mtDNA lower, or similar to, levels found in other populations in Alaska? 3) Is there concordance between low levels of genetic variation observed at neutral markers with levels of variation observed at functional genes? 4) Is there population substructuring within Kodiak and Afognak islands? 5) What is the connectivity between populations on Afognak Island and Kodiak Island? 6) What are the phylogeographic relationships between bears of the Kodiak Archipelago with brown bears on mainland Alaskan and other western Beringian populations? We also test whether these markers will provide an appropriate baseline for designing genetic tagging studies for use in future research and management activities, such as mark-recapture efforts, on the Refuge.

Materials and Methods

Sample Collection and Extraction

Blood and tissue samples were collected from Kodiak Archipelago brown bears while they were handled during related radio-telemetry studies, or from harvested bears, between 1991 and 2004. Blood samples were stored in whole blood Vacutainer® tubes containing EDTA. A list of all samples and associated locale data are provided as Appendix 1; distribution of samples are listed in Figure 1. Muscle and skin biopsies were kept frozen after sampling at -80° , and shipped on wet ice from Kodiak, or from the University Alaska Museum (UAM) to the Molecular Ecology Laboratory (MEL) at the U. S. Geological Survey Alaska Science Center. Tissue samples were extracted according to Medrano et al. (1990). Blood samples were extracted using Epicentre® Masterpure™ DNA Purification Kit for Blood (Epicentre Cat. No. MG71100, Epicentre®, Madison, Wisconsin) spin-columns. Samples were diluted as appropriate to 50ng/ μ L concentration prior to further laboratory processing.

Genotyping and Sequencing

Primers targeting 14 variable nuclear microsatellite loci were selected from Ostrander et al. (1993), Taberlet et al. (1997), and Paetkau et al. (1995, 1998a, b). Microsatellite loci were assayed using the multiplex polymerase chain reaction (PCR) and fluorescently-labeled (IRD700 and IRD800) primers, using methods outlined in Jackson et al. (2005). Products were visualized on a LI-COR Long ReadIR™ 4200 automated sequencer, using a 6% denaturing polyacrylamide gel. Individuals representing each locus were compared to an M13 sequence ladder of known size, and to samples of known genotype obtained

from D. Paetkau (Wildlife Genetics International, British Columbia, Canada) to allow future calibration of datasets from different laboratories. Samples sized against these standards were used in each subsequent gel as size standards. Negative controls were included in all reactions for the detection of contamination, and 10% of all samples were re-extracted and reprocessed for quality control. Microsatellite fragment data were analyzed using Gene ImageIR™ Data Analysis software (Scanalytics, Inc., Fairfax, Virginia).

PCR primers specific to ursid mtDNA were used to amplify a target fragment including a portion of the cytochrome *b* gene, the tRNA^{thr} and tRNA^{pro} genes, and the hypervariable portion of the control region (Wakely 1993). The light-strand primer L15774b (5'-GAA TTG GAG GAC AAC CAG T-3') which anneals to the 3' end of the ursid mtDNA cytochrome *b* gene, and the heavy-strand primer anneals to the Conserved Sequence Block C of the ursid mtDNA control region (H00019: Talbot and Shields 1996a). We used the primers DQBF (5'-GAT TTC GTG TAC CAG TTT AAG GGC-3') and DQBR (5'-CCA CCT CGT AGT TGT GTC TGC A-3') to amplify a 241 base pair (bp) fragment of the putative MHC class II DQB1 exon 2. We used the primers DQAF (5'-GAT GGA GAT GAG GWG TTT TAY GTG GA-3') and DQAR (5'-CCA CRG WCA ACC GCA GGG CAC A-3') to amplify a 1121 bp fragment of the MHC class II DQA gene. Primers were synthesized with an added universal M13F(-29) and M13Rev tail on the light and heavy strand primers, respectively. PCR products were electrophoresed in TBE (89mM Tris, 89mM boric acid, 2mM EDTA) against a 100bp DNA ladder on a 1.0 1.5% agarose gel stained with ethidium bromide, and visualized under ultraviolet light. PCR products were purified using Quantum Prep® PCR Kleen Spin Columns (BIORAD: Hercules, California). Purified products were cycle-sequenced via simultaneous bidirectional sequencing (SBS: LI-COR 1998) using a commercial kit (Sequitherm LCII 2.0®: Epicentre Technologies, Madison, Wisconsin). We used fluorescently-labelled universal primers [LI-COR: M13F (-29) and M13Rev] to prime the SBS reaction. For quality control purposes, DNA from 10 individuals representing each designated subpopulation were extracted, amplified and sequenced in duplicate. MtDNA sequences were analyzed using LI-COR eSeq™ imaging software and aligned using AlignIR 2.0™ (LI-COR Inc., Lincoln, Nebraska).

Linkage and Hardy Weinberg Equilibrium

We used Excel Microsatellite Toolkit (version 2.1, Park 2001) to prepare data for analysis. All microsatellite loci were tested for gametic phase disequilibrium and for deviations from Hardy-Weinberg equilibrium (HWE) using the Fisher's Exact Test in GENEPOP 3.1 (Raymond and Rousset 1995). We set two *a priori* conditions for retention of loci for analysis: to exclude one of any pair of loci found to be significantly linked, and to exclude any loci found to deviate from HWE from any analyses requiring conformation to Hardy-Weinberg proportions.

Genetic Diversity

We estimated the mean observed heterozygosity (H_O), expected heterozygosity (H_E), mean number of alleles per locus, and allele size variance using BIOSYS-L (Swofford and Selander 1981). Allelic richness (r_g ; El Mousadik and Petit 1996) was estimated using FSTAT (ver 2.9.3, Goudet 1995, 2001). Estimates of H_O and H_E were used to generate the inbreeding coefficient ($F = 1 - [H_O / H_E]$) combined across loci for each population (Wright 1951). Significance of F was tested as described in Li and Horovitz (1953). Overall F_{IS} (inbreeding coefficient) and significance of F_{IS} was calculated using FSTAT. Average relatedness and variance (Queller and Goodnight 1989) were estimated using Identix (Belkhir et al. 2002). MtDNA control region and MHC DQA and DQB haplotypes were assigned based on at least a single nucleotide substitution or insertion/deletion (indel) found within the segment sequenced. We used ARLEQUIN 2.0 (Schneider et al. 2000) to estimate haplotype (h) and nucleotide (π) diversity (Nei 1987, Eq. 8.4 and 10.6, respectively) for mtDNA data.

Genetic Differentiation

Significance of spatial variation was assessed using F-statistics (Weir and Cockerham 1984). These measures can be viewed simply as variance components that describe the apportionment of allelic variance among individuals within (F_{IS}) and among (F_{ST}) populations. Values of F_{ST} are summary statistics ranging essentially from 0 to 1 that describe the extent of spatial variation among populations or population groups. A value of 1 at a specific locus would imply that all populations are fixed for different alleles (i.e., the total variance at that locus is segregating among populations). A value of 0 implies all populations share the same alleles in equal frequency (panmixia). Overall multilocus (microsatellite) estimates of F_{ST} variance, θ , were obtained using FSTAT (Ver 2.9.3, Goudet 2001). Estimates of interpopulational variance (θ) were derived using the program ARLEQUIN 2.0 (Schneider et al. 2000). Significance of θ values were based on random permutation tests ($n = 1,000$), whereby alleles were randomly permuted between two populations. A significant value of θ implies that a significant portion of the total genomic variation across loci is partitioned among populations. We further examined substructuring of Kodiak Archipelago brown bear populations using a Bayesian clustering approach (Structure 2.0: Pritchard et al. 2000) to estimate the likely number of populations occurring on Kodiak and Afognak islands, both pooled and unpooled. We also tested for significance of heterogeneity of microsatellite alleles between populations, as described in Raymond and Rousset (1995), using ARLEQUIN. For significance testing, all α -values were set at 0.05 and, where appropriate, adjusted using Bonferroni procedures (Rice 1995).

Heterogeneity of mtDNA haplotypes between the Kodiak and Afognak populations was assessed using Monte Carlo re-sampling of haplotype variation using REAP 4.0 (McElroy et al. 1991). We used the maximum likelihood criterion in Modeltest 3.06 (Posada and Crandall 1998) to determine the evolutionary model that best fit the sequence data. These distances were used to calculate Φ_{st} (Excoffier et al. 1992), which tests for interpopulational variance at mtDNA loci, and tested for significance using ARLEQUIN 2.0 (Schneider et al. 2000).

Population Relationships

We used allele frequencies at microsatellite loci to calculate Cavalli-Sforza and Edwards (1967) chord distances among populations and constructed multi-locus population neighbor-joining tree bootstrapped trees (3000 replicates) using the program NJBP² (J.R. Cornuet, INRA, Laboratoire de Neurobiologie Comparée des Invertébrés, Bures-sur Yvette, France). This distance method produces robust tree topologies for groups separated for time periods comparable to the brown bear populations (Takezaki and Nei 1996). We also determined population relationships based on mtDNA control region data by constructing neighbor-joining population trees using coancestry coefficient distances (Reynolds et al. 1983) using ARLEQUIN and MEGA 2.0 (Kumar et al. 2001). For the microsatellite population tree we included data from Afognak and Kodiak islands, Katmai National Park and Kamchatka, Russia, with preliminary data from 16 individual bears from southcentral Alaska added for comparative purposes. For the mtDNA population tree, we include data from 6 other populations in interior and western Alaska, and from Kamchatka.

Detection of Bottlenecks

We used BOTTLENECK 1.0 (Piry et al. 1999) to perform the Wilcoxon test to detect excess heterozygosity of polymorphic microsatellite loci resulting from a recent bottleneck (Nei et al. 1975, Cornuet and Luikart 1996). Tests were conducted under the infinite alleles model (IAM: Ohta and Kimura 1973, Maruyama and Fuerst 1985), the stepwise mutation model (SMM: Freimer and Slatkin 1996), and the two-phase model (TPM: Di Rienzo et al. 1994) of microsatellite mutation. These models span the range of mutational models hypothesized to operate on microsatellite loci. Parameters for the TPM were set at 88% SMM with a variance of 9 (Piry et al. 1999, Garza and Williamson 2001).

We also used the program AGARst (Harley 2002) to determine M , the mean ratio of number of alleles to total range in allele size (Garza and Williamson 2001). Unlike heterozygosity excess (Cornuet and Liukart 1996), M can detect reductions

within populations that occurred more historically (over 100 generations past; Garza and Williamson 2001). We used Critical_M.exe (http://santacruz.nmfs.noaa.gov/staff/carlos_garza/software.php) to infer critical M values (M_C), which were calculated using pre-bottleneck effective population sizes (N_e) of 50 to 1500 for KOD, and 25 to 250 for AFOG. These were determined as in Allendorf et al. (1991), who recommended that pre-bottleneck effective population sizes be one quarter the high and low estimates of actual population size. We used a constant mutation rate ($\mu = 5 \times 10^{-4}$ locus/year), and the TPM model whereby 88% of mutations are single-step changes and the average size of all other mutations is 3.5 repeats.

Marker Resolution for Genetic Tagging Studies.

We used the statistical program, GIMLET 1.3.2 (Valieré 2002), to generate $P_{(IDobs)}$ and $P_{(IDsib)}$ values to determine whether the microsatellite markers are sufficiently variable to allow for use in individual identification in genetic tagging studies. $P_{(IDobs)}$ is the probability at which another individual with the same genotype would be observed, given the sample frequency of the alleles observed at those loci, within the population. $P_{(IDsib)}$ estimates the probability of observing identical multilocus genotypes between two individuals sampled from a population comprised of first-order relatives (e.g., between siblings or parent-offspring). General guidelines for genetic tagging studies suggest using a suite of markers that achieve a reasonably low $P_{(ID)}$ bounded between 0.01 and 0.0001; $P_{(IDsib)}$ provides a conservative upper bound on this estimate (Waits et al. 2001).

Population Demographics

Evidence of population expansion was tested using multiple methods for mtDNA data. Rapid population expansion leads to low levels of diversity among haplotypes over large areas (Hewitt 1996), producing basal polytomy or star-like phylogenies (Avice 2000). Fu's F_S values test for neutrality of the data, and also may indicate groups that have recently expanded (Fu 1997). Negative Fu's F_S values suggest population expansion. We used ARLEQUIN to estimate haplotype and nucleotide diversities. Haplotypic diversity (h) is the probability that two randomly chosen haplotypes differ (Schneider et al. 2000) and varies from 0 to 1 (Grant and Bowen 1998). Nucleotide diversity (π) is the probability that two randomly chosen homologous nucleotides are different (Schneider et al. 2000) and varies from 0, for no divergence, to over 0.10 for deep divergences (Grant and Bowen 1998). Thus, high h and low π indicate an excess of different haplotypes with minimal variation, and suggest a rapidly expanding population (Avice 2000).

Phylogeographic Analyses of MtDNA Sequence

Phylogenetic analyses of control region sequences were conducted using PAUP*4.0b8 (Swofford 2000), using maximum likelihood (ML) and distance (minimum evolution, ME). The simplest evolutionary model of DNA substitution that was significantly better than less complex models, was determined using the hierarchical nested likelihood ratio tests implemented in MODELTEST version 3.06 (Posada and Crandall 1998) to be HKY+I+G (Hasegawa et al. 1985), incorporating a gamma distribution shape parameter of 0.4796. For this model, the transition to transversion ratio was estimated at 31.404. We thus weighted transversions 31:1 over transitions in subsequent analyses where appropriate. The HKY+I+G model was used in maximum likelihood and maximum likelihood distance tree reconstructions. Heuristic tree searches were conducted for each analysis, with 20 and 100 random additions of taxa for maximum likelihood and parsimony analyses, respectively, each followed by tree bisection-reconnection topological rearrangements. Robustness of nodes was assessed using tree reconstructions of bootstrap-resampled data sets for 1,000 replicates under distance and parsimony criteria, and 200 replicates for ML criteria. Phylogenetic comparisons were made using a dataset comprised of haplotypes observed among 14 populations of brown bears in Alaska as well as those observed in 6 bears of Kamchatka and elsewhere in eastern Siberia (Talbot, unpublished data; Leacock, unpublished data).

Analysis of MHC DQB and DQA Sequences

Our first concern with the MHC loci was to correctly identify the MHC genes, since these genes occur as families and varying levels of multiformity has been observed (Bowen et al. 2004). Once identified, we then compared levels of genetic diversity (in terms of number of observed alleles) at the identified locus between populations inhabiting the Kodiak Archipelago, and those of a less isolated population (KAT), to determine if the low level of genetic diversity at neutral genetic markers is also reflected in the MHC loci. To identify the genes, we used FUGUE (Shi et al. 2001) and BLAST (Altschul et al. 1997) analyses to compare sequences we obtained from the putative MHC genes with homologous sequences already identified for other species and available on public databases. All sequences were aligned with MHC DQB or DRB sequences from elephant seal (*Zalophus californianus*; Bowen et al. 2002), wolf (*Canis lupus*; Seddon and Ellegren 2002), human (*Homo sapiens*; Apple et al. 1993, Kimura, unpublished data) and polar bear (*Ursus maritimus*, Wei and Happ, unpublished data) and translated into corresponding amino acid sequences using MEGA (Ver. 2.0, Kumar et al. 2001). Amino acid positions involved in peptide binding were identified by comparison with the peptide binding groove structure of the human class II molecule (Brown et al. 1993). Relative frequencies of nonsynonymous (dN) and synonymous (dS) substitutions were calculated for the peptide binding region, the non-peptide-binding region, and the entire sequence according to Nei and Gojobori (1986) using the Jukes-Cantor (1969) correction. All dN and dS frequencies and standard errors were estimated using MEGA. Genetic distance matrices were estimated using the Kimura 2-parameter model (Kimura 1980). Phylogenetic relationships among alleles were estimated using minimum evolution (neighbor-joining) methods, using MEGA.

Project Management and Acknowledgements

Study concept and design was performed by T. Fischbach, L. Van Daele and S. Talbot. The bulk of the laboratory work was conducted by G. K. Sage, J. R. Gust, K. Amstrup and S. L. Talbot. G. K. Sage, J. R. Gust and S. L. Talbot processed and proofed genetic data. All laboratory analyses were conducted at the Alaska Science Center's (ASC) Molecular Ecology Laboratory (MEL) in Anchorage, Alaska. Data analyses were conducted by S. Talbot, G. K. Sage and J. Gust. Sample acquisition was performed by L. Van Daele and T. Fischbach for Kodiak Archipelago bears, with additional samples provided by the ASC from archived specimens. Nucleotide sequence data from brown bears from other populations (Alaska, Siberia and Turkey) were provided by S. Talbot; data from Kamchatka brown bears were collected from samples funded by field work of W. Leacock as part of his Ph. D. dissertation research. A portion of the microsatellite data from Kamchatka was collected by J. Jackson and G. Petersen, ASC. Microsatellite data from Katmai National Park were provided in part by K. Scribner (ASC, MSU) and S. Talbot. Curation of Kodiak Archipelago samples was provided by T. Fischbach and J. Gust. Critical reviews and comments of analyses were contributed by J. Pearce, D. Derksen, and B. Pyle. We thank the University of Alaska Museum, as well as numerous staff members of the U. S. Fish and Wildlife Service and the Alaska Department of Fish and Game,

for providing samples. Financial support for analyses was provided by U. S. Fish and Wildlife Service, Kodiak National Wildlife Refuge, the U. S. Geological Survey Alaska Science Center, and the Alaska Department of Fish and Game.

Results

Data Collection

We obtained data from brown bears of Afognak Island (AFOG; $n = 29$), and Kodiak Island (KOD; $n = 218$). General sample locations are given in Figure 1. Data include 1) fragment analysis of 14 microsatellite loci, 2) nucleotide sequence data from 589 – 592 base pair (bp) segment of mtDNA (comprising 106 bp of the cytochrome *b* gene, 70 bp of the tRNA-thr, 65 bp of the tRNA-pro, and 348-351 bp of the hypervariable portion of the control region, 3) a 228 bp segment from the putative ursid MHC class II DQB1 gene, and 4) a 1194 bp segment from the putative ursid MHC DQA1 gene. For comparative purposes, we include allele and haplotype frequency data from brown bears from Katmai National Park, Alaska (KAT; $n = 29 - 41$) and Kamchakta, Russia (KAM, $n = 11$), and phylogeographic comparison involving 358 brown bears from among 14 populations in Alaska, two populations in Russia, and from Turkey (Talbot, unpublished data; Leacock, unpublished data).

Matching Samples

Among the 218 individuals from KOD, 14 bears involved in 9 pair-wise comparisons possessed identical genotypes at all 12 polymorphic loci (Appendix 2). One of each pair was eliminated from further analysis. Thus, 209 brown bears from KOD were included in all subsequent analyses of microsatellite data. No individuals from AFOG shared multilocus genotypes.

Linkage and Hardy Weinberg Equilibrium

The KOD population exhibited significant deviations from HWE at three loci (G1A, $p = 0.008$; G10J, $p = 0.049$; UAR μ 50, $p = 0.029$; $\alpha = 0.050$; Table 1), due to heterozygote deficit. AFOG exhibited no deviations from HWE at any locus. Two loci were monomorphic in both AFOG and KOD (G10H, G10M; Table 1). After excluding these 5 loci, we found no significant

linkage disequilibrium among loci in either population. The three loci found to deviate from HWE were excluded from any analysis that depends upon Hardy-Weinberg proportions. Because we present levels of polymorphism as one type of genetic diversity, we calculated comparative genetic diversity indices using all 14 loci.

Genetic Diversity

Levels of genetic diversity at 14 microsatellite loci for bears of the Kodiak Archipelago, KAT and KAM are given in Table 1. Genetic diversity values (polymorphism, heterozygosity and allelic richness) in Kodiak Archipelago populations were substantially lower than values observed in KAT and KAM (Table 2). H_O for brown bears on AFOG was 0.259 (SE = 0.049); H_E was 0.270 (SE = 0.050). Overall H_O for KOD was 0.263 (SE = 0.058); H_E was 0.280 (SE = 0.062) (Tables 1 and 2). Allelic richness was 2.01 and 2.26 for AFOG and KOD, respectively. The mean inbreeding coefficient was not significantly different from zero ($F = 0.041 - 0.061$; $\chi^2 < 3.84$, $df = 1$) for KOD and AFOG (Table 2), and F_{IS} was not significantly different from zero ($F_{IS} = -0.021$ and 0.040 ; $p > 0.05$, Bonferroni correction applied). Average relatedness was similar across populations; variance was highest for AFOG (Table 2).

Sequence Diversity

Seven mtDNA control region haplotypes were identified among 124 Kodiak brown bears; one haplotype was observed among 28 bears from AFOG (Table 2, 3). Four haplotypes occurring on KOD were unique (private haplotypes); one haplotype was shared by AFOG (and one with Magadan, Russia), and one haplotype was also observed in seven other populations in Alaska (see Figure 2 and associated legends). Fifteen polymorphic sites, including 5 insertions/deletions (indels) and 10 transitions, separated the haplotypes (Table 3). Haplotype (h) and nucleotide diversity (π) was lowest in AFOG (Table 2). In AFOG, F_u 's F_S was positive (not significant), and Tajima's D was not significantly different from zero; F_u 's F_S and Tajima's D were both for negative for KOD and significantly different from zero (Table 2).

Genetic Differentiation

STRUCTURE analysis detected only one population each in AFOG ($\ln \Pr(X | K) = -360.1$; $\log P = 0.634$; based on 12 loci), and KOD ($\ln \Pr(X | K) = -2253.3$; $\log P = 0.208$; based

on 9 loci). When AFOG and KOD were pooled under an admixture model, STRUCTURE detected two populations ($\ln \Pr(X | K) = -2338.9$, $\log P = 0.9866$). These results are consistent with lack of sub-structuring within KOD and AFOG. Analysis of variance indicated that > 99% of variation at microsatellite loci occurred among individuals within both KOD, and AFOG (data not shown). Pairwise θ values between AFOG and KOD were significantly different from zero ($\theta = 0.116$, $p = 0.000 \pm 0.000$; Table 4). However, pairwise ρ values were not significantly different between AFOG and KOD ($\rho = 0.038 \pm -0.0072$, $p = 0.045$, $\alpha = 0.005$). Analysis of mtDNA sequence data, using Modeltest 3.06 (Posada and Crandall 1998) suggested the best evolutionary model fit to the data was the HKY+I_(0.7107)+Γ_(0.4796) model (Hasegawa et al. 1985); this model was used to generate pairwise distances used in AMOVA analysis (see below). We detected significant difference between AFOG and KOD in the distribution of mtDNA haplotypes using Monte Carlo simulation ($p = 0.000 \pm 0.000$), and when F_{ST} values were based on frequency alone ($F_{ST} = 0.307$, $p = 0.000 \pm 0.000$), but not in the variance in haplotype frequency when a model of evolution was invoked ($\Phi_{ST} = -0.012$; $p = 0.559 \pm 0.0158$; Table 4). Both AFOG and KOD were significantly differentiated from KAT and KAM at both microsatellite loci and mtDNA (Table 4). Expanded analyses including comparison of mtDNA variance in haplotype frequency involving pair-wise comparisons among 14 populations of brown bears in Alaska, and KAM, demonstrated that both KOD and AFOG are significantly differentiated from all other populations assayed in Alaska (data not shown).

Population Relationships

The neighbor-joining tree based on overall genetic similarities among populations, calculated using Cavalli-Sforza and Edwards (1967) chord distances for microsatellite data, placed AFOG and KOD together with high bootstrap support (100%, see Figure 3), clustering away from KAT and south central Alaska (SCEN); the latter were also placed together with high bootstrap support. KAM clustered together with KAT and SCEN, away from KOD and AFOG, but without bootstrap support (Figure 3). A similar topology was obtained using net shared alleles (data not shown). The neighbor joining tree based on the coancestry coefficient (Reynolds et al. 1983) from the mtDNA control region data placed Seward Peninsula (SPEN) together with AFOG (Figure 4), both clustered with KOD.

Contemporary and Historical Population Demographics

There was no evidence of significant heterozygosity excess, expected in the case of a recent contemporary bottleneck (within the past two to 20 generations; G. Luikart, pers. comm.), on either KOD or AFOG using the Wilcoxon one-tailed test under any of the models of evolution, after the application of Bonferroni corrections ($p > 0.005$, Table 5). A significant deficit of heterozygosity was observed in KOD under the SMM using the Wilcoxon one-tailed test for heterozygosity deficit ($p = 0.003$, Table 5). Values of M for both AFOG and KOD (0.375 and 0.600, respectively) were significantly lower than the calculated range of critical values ($M_C = 0.650 - 0.739$, depending upon estimated theta values of 3 to 0.05). Locus G10D (Paetkau 1998a, b) was excluded from the calculation of M , due to the presence of a single base pair difference in allele size.

Negative Fu's F_S values (Table 2) were obtained for all populations except AFOG. For KOD in particular, these values corroborate haplotypes and nucleotide diversity values and the star-like topology of the phylogenetic trees (see results in *Phylogeographic Analyses* section below), suggesting rapid historical (post-Pleistocene) population expansion.

Marker Resolution for Genetic Tagging Studies

Probability of identity values for AFOG and KOD are given in Table 6. A 12-locus genotype appears adequate to distinguish an individual from among 4184 individuals on AFOG ($P_{(ID_{obs})} = 0.000239$; $P_{(ID_{sib})} = 0.020422$), and among 5649 individuals on KOD ($P_{(ID_{obs})} = 0.000177$; $P_{(ID_{sib})} = 0.015098$). Nevertheless, match statistics (Appendix 2) suggested these 12 loci were not able to distinguish among 14 individual brown bears on KOD. $P_{(ID_{obs})}$ and $P_{(ID_{sib})}$ values are larger within both AFOG and KOD than recommended by Waits et al. (2001). Comparative data from KAT suggest the same 12-locus suite is adequate to distinguish an individual among 294,550 first order relatives ($P_{(ID_{sib})} = 0.00000339$; data not shown).

Phylogeographic Analyses

Similar to results shown in earlier research that compared nucleotide sequence information from the brown bear cytochrome *b* and two tRNA genes (Talbot and Shields 1996a), our mtDNA control region data show that brown bears in Alaska fall into three distinct clusters: 1) a “western Beringian” cluster, corresponding to Clade III of Talbot and Shields, 1996a); 2) an

“eastern Beringian” cluster, corresponding to Clade II of Talbot and Shields 1996a), and a cluster comprised of individuals inhabiting the islands of the Alexander Archipelago, corresponding to Clade I, Talbot and Shields 1996 (Figure 2a, b). Bears of the Kodiak Archipelago fall clearly within the “western Beringian” cluster, in an unresolved, star-like phylogeny (Figure 2b). Haplotypes found in the Kodiak Archipelago cluster more closely with haplotypes from SPEN and Brooks Range (BR) than the Alaska Peninsula [KAT, Izembek NWR (IZE)] or KAM. Nevertheless, bootstrap support for the placement of SPEN and BR close to haplotypes in the Kodiak Archipelago is not high (Figure 2a).

MHC DQA and DQB Analyses

Initial screening of 1194 bp of the DQA gene uncovered four DQA haplotypes among six individual bears from three different populations in south central Alaska and the Kodiak Archipelago (SCEN, n = 3; KAT, n = 1; KOD, n = 3). Similar screening of 228 bp of DQB gene uncovered 11 haplotypes among 13 bears screened from Alaska (SCEN, n = 2, KAT, n = 4, KOD, n = 2, KEN, n = 3, SEAK, n = 2; data not shown). Due to overall lower levels of haplotypic and nucleotide diversity among brown bears of Alaska at the larger DQA locus relative to the DQB locus (data not shown), we dropped this locus from further consideration and concentrated on obtaining data at the more variable DQB locus. Variation at the DQA locus is shown in Appendix 3.

Ten different sequences (alleles) were observed among the 80 bears typed among KOD, AFOG and KAT at the DQB locus (Table 7). BLAST (Altschul et al. 1997) and FUGUE (V2.s.07, Shi et al. 2001) analyses suggest the ten sequences obtained from brown bears in Alaska are homologous with the MHC class II DQB1 exon 2 sequences (Z-score 9.17 to 23.41, $p < 0.01$) from humans and mice (*Mus musculus*). We illustrate this in an alignment comparing the DNA sequences of all 10 DQB alleles and five outgroup sequences (Figure 5) and an alignment of translated sequences using the same outgroups (Figure 6). We observed no indels, and no stop codons (indicative of pseudogenes of DQB1 exon 2, Bowen et al. 2002). The amino acid alignment illustrates the conservation of motifs between brown bear, gray wolf, elephant seal, and human DQB1 exon 2 sequences that are not shared with human DQB2 sequences or sequence from the polar bear MHC DRB gene. This, and the finding that multiple amplification of the same individuals never revealed more than the observed sequences (data not shown),

suggest we were successful at amplifying a single locus from the brown bear and that the amplified locus is homologous to the human leucocyte antigen and the dog leucocyte antigen (DLA) DQB1 exon 2 locus.

Polymorphisms at MHC class II loci, including DQBI, occur predominantly in exon 2, which codes for a majority of the peptide binding region (PBR). The exon translates into a sequence length of 83 amino acids with 16 possible amino acid binding sites (ABS) for presentation to foreign peptides (Brown et al. 1993). Here we have information from 228 base pairs that code for 76 amino acids for the *U. arctos* DQB1 exon 2 gene (*UrarDQB1*; Figure 5 and Figure 6) with 15 possible ABSs. Seventeen polymorphic sites, including 7 transitions and 10 transversions, were observed among all brown bears sequences (Figure 5). Only two of the 17 site substitutions were synonymous (e.g. did not result in a change of amino acid), neither of which are at putative ABSs (Figure 6); the remainder of variable sites resulted in nonsynonymous substitutions (Figure 6). In an alignment of the 76 inferred exon amino acid sequences obtained for *UrarDQB1*, we found that the majority (67%) of amino acid changes (at residues 21, 23, 30, 54, 60 and 67) were at putative ABSs (Figure 6). In the total sequence examined, there were 15 positions that were ABS and 61 that were non-ABS.

The relative frequency of non-synonymous substitutions ($dN = 0.084$, $SE = 0.000$) was larger than the frequency of synonymous substitutions ($dS = 0.000$, $SE = 0.000$) in the ABS for all alleles, with a dN/dS ratio greater than one. This suggests selection for diversity (balancing selection) in these positions (Tamura and Nei 1989). In the non-ABS region, non-synonymous substitution occurred less frequently ($dN = 0.018$, $SE = 0.008$) than synonymous substitutions ($dS = 0.024$, $SE = 0.013$); the dN/dS ratio is less than unity for the non-ABS region.

One of the 10 sequences typed was observed in AFOG; this same sequence type (allele) was found in 31 of the 32 bears typed from KOD (Table 7). The substitutions observed between the two sequences found on KOD were non-ABS, but were non-synonymous changes. Eight of the 10 sequences were observed in bears of KAT (Table 7). We observed little evidence of heterozygous individuals (single individuals with more than one allele at this locus) within Kodiak Archipelago brown bears, which would have been detectable as comigration of fragments terminated at more than one base. However, there was evidence of heterozygosity within KAT (data not shown). The ability to discern the level of heterozygosity within the KAT populations will require additional development.

A neighbor-joining tree for the 10 *UrarDQB1* nucleotide sequences was constructed using outgroup sequences derived from human, elephant seal, dog, and polar bear. Genetic distances were estimated using the Tamura-Nei (Tamura and Nei 1993) and Kimura 2-parameter (Kimura 1980) distance model. Both distance models produced strongly supported trees of equal topology, revealing 2 evolutionary lineages; Figure 7 shows Tamura-Nei distances. Within lineage I, the two alleles found within the Kodiak Archipelago cluster closely together, away from alleles found in bears from KAT, while lineage II comprises *UrarDQB1*004* and *UrarDQB1*007*. The neighbor joining tree suggests the alleles from the Kodiak Archipelago (*UrarDQB1*001* and *UrarDQB1*002*), which cluster together with 75% bootstrap support, are recently derived. Other nodes also show high bootstrap support, but in general the topology within lineage I is shallow.

Discussion

Genetic Diversity and Substructuring at Neutral DNA Markers

Our microsatellite data based on larger geographic coverage across Kodiak Island and increased sample sizes confirm earlier findings of low levels of genetic variation in Kodiak brown bear based on similar data from brown bears from the Aliulik Peninsula of Kodiak Island alone (Paetkau et al. 1998b). This pattern of low genetic variation is also evident within AFOG. We found little statistical evidence of substructuring within KOD or AFOG, based on nuclear microsatellite loci. Nevertheless, we found significant spatial differentiation between KOD and AFOG at both nuclear microsatellite and mtDNA loci, when analyses of variance consider allele or haplotype frequencies only (without incorporating a model of evolution). This finding suggests that the two populations within the Archipelago are evolutionarily recently diverged but not sufficiently connected via recent gene flow to maintain panmixia. This is surprising, given the small distances between the two islands and the demonstrated ability of brown bears to swim across large bodies of water (see discussion in Paetkau 1998a). Analyses of molecular variance (e.g. when considering a model of evolution in addition to frequency of alleles) failed to reject the null hypothesis of panmixia. If these two populations are more subject to drift and migration (e.g., the populations are very recently diverged and differentiation, while significant, is still shallow), then F_{ST} -based tests are more appropriate than tests invoking a model of evolution

(Slatkin 1995), such as R-statistics for microsatellite loci and Φ_{ST} values for mitochondrial DNA which incorporate a model of evolution.

Levels of genetic variation at the mtDNA in KOD are higher than on AFOG. We observed seven mtDNA control region haplotypes on KOD among 124 bears, and one on AFOG (among 28 bears). Fewer haplotypes were observed on KOD (and AFOG) than on KAT, where nine haplotypes were observed among 41 bears. However, it is also important to distinguish the *type* of variation that differentiates haplotypes within the Kodiak Archipelago and that observed on the mainland population of KAT and elsewhere in Alaska. Haplotypes (and thus haplotype diversity) are defined based on a single site difference, and such differences can include indels as well as site substitutions (transitions and transversions). However, not all site differences are equally likely to occur. Among the site changes observed among the seven haplotypes typed in bears on the Kodiak Archipelago, only two (UARCR30 and UARCR33) involved site substitutions (transitions); the remainder of the differences occurred as differences in the number of thymine (T_n) repeats at the 5' end of the control region (indels). Conversely, eight of the nine haplotypes observed among KAT bears, and all four of the haplotypes found in KAM, were defined by both transition substitutions and T_n repeats.

Variation in the T_n repeat number at the 5' end of the brown bear control region likely occurs through DNA replication slippage in cells similar to the type explaining mutation at microsatellite loci (Levinson and Gutman 1987, Hancock 1999). Such hypervariable sites within the control region are considered “mutational hotspots”, or nucleotide sites that evolve at a rate much faster rate than average (Stoneking 2000). This type of variation has been observed in control region sequences of bears in all other populations in Alaska (except on the Kenai Peninsula; S. Talbot, unpublished data; Jackson et al. 2005). Mutations at the T_n repeat region within brown bears may occur more frequently than site substitutions (Matsuhashi et al. 1999), and thus haplotype diversity values based on differences at this site may be biased upward, resulting in misleading levels of comparative haplotypic diversity. It is possible that variation observed at the T_n repeat in Kodiak bears may be the result of mutation occurring subsequent to the immigration and isolation of brown bears (possessing different lineages) on the Kodiak Archipelago. This scenario has been proposed for bears of Hokkaido, Japan (Matsuhashi et al. 1999), which, like Kodiak Island, are thought to have been isolated from mainland populations for about 12,000 years.

In addition to the T_n repeats at the 5' end of the control region, we have also observed 10 bp repeat arrays (SLT, unpublished data) at the 3' end of the control region in Alaskan brown bears. Such repeats, found in other mammals (Hayasaka et al. 1991, Wilkinson and Chapman 1991, Hoelzel 1994, Casane et al. 1997, Lunt et al. 1998), were reported for Hokkaido bears (Matsuhashi et al. 1999) and used to understand post-immigration relationships of bears of Hokkaido. In bears of KOD, this repeat array includes an 11 bp motif, ACGTACGCATA, that repeats approximately 29 times (S. Talbot, unpublished data). This region may be useful in assessing microgeographic variation within subpopulations of brown bears on Kodiak, since this array, like the 5' T_n repeat array, may be more likely to occur than site substitutions (Matsuhashi et al. 1999). However, the 3' repeat arrays show heteroplasmy (more than one copy within an individual) in some individuals within populations in Alaska (SLT, data not shown) and Hokkaido (Matsuhashi et al. 1999), perhaps due to natural DNA replication errors, or to artificial slippage via PCR (Madsen et al. 1993). Conversely, heteroplasmy was not observed at the 5' T_n repeat array. Duplicate PCR amplification and sequencing, including use of different sequencing platforms and protocols, yielded identical 5' T_n repeat arrays for the same individual, suggesting little or no heteroplasmy at this repeat. We suggest the 5' sequence patterns observed within KOD and AFOG may provide a more useful tool for investigating microgeographic population structure as well as potentially providing an additional marker for individual identification, since low $P_{(ID_{obs})}$ values for 14 microsatellite loci for KOD and AFOG suggest additional markers would be required for genetic tagging studies.

For example, in the brown bear population on Hokkaido, different mtDNA lineages based on these 5' (T_n) and 3' repeat arrays were found to be geographically segregated. This may be due to female philopatry and the tendency of dispersing females to establish territories adjacent to their mothers (Rogers 1987, Schwartz and Franzmann 1992, Craighead et al. 1998). Although STRUCTURE analysis failed to uncover substructuring within KOD or AFOG based on nuclear microsatellite data, an obvious next step in the research is to plot female haplotypes across the landscape and determine whether substructuring occurs at the mtDNA. An initial exploration of our control region data suggests substructuring does occur at mtDNA; simply mapping mtDNA haplotype frequencies (for females only) across the archipelago suggests that mtDNA lineages are arranged non-randomly, and indeed appear to be geographically segregated (Figure 8). Again, this pattern, coupled with the lack of substructuring observed at nuclear microsatellite

data, is consistent with the tendency of young female brown bears to settle in home ranges closer to their mother's home ranges (female philopatry), and of males to disperse farther, leading to largely male-mediated gene flow. It is of interest that the haplotype observed on Afognak (UarCR30) is observed at highest frequency in the northern portion of Kodiak Island, the most likely source of colonizers (Figure 8).

Phylogenetic Relationships

Three taxonomic hypotheses give subspecies status (*U. a. middendorffi*) to bears of Kodiak Island and, presumably, to the rest of the Kodiak Archipelago, including Afognak Island (Rausch 1963, Kurtén 1973, Hall 1984). While we observed six unique haplotypes on the Kodiak Archipelago, the second most common haplotype on the Archipelago, UARCR9 (the most common type found on KOD), also occurs to varying degrees in all other regions of mainland Alaska examined here, except in southcoastal Alaska and the Alexander Archipelago (Figure 2a,b). Thus, our phylogenetic analyses of haplotypes suggest that Kodiak Archipelago bears share a close evolutionary relationship to bears of BR, KAT, SP and SCEN (Figure 2a, b). Examination of Figure 2 (a, b) suggests this relationship is shallow, without the deeper, reciprocally monophyletic lineages characterizing a taxon that is evolving independently over (on average) $2N_{ef}$ generations (Zink 2003). By this criterion, the relationship among Alaskan populations or clades/clusters, based on mtDNA sequence information, presented in Figure 2a, suggests subspecies status of Kodiak Archipelago brown bears is less defensible than subspecies status of bears of the Alexander Archipelago of southeastern Alaska, given criteria based on the evolutionary history of Kodiak Island based on neutral genetic markers alone.

Talbot and Shields (1996a) report findings similar to those presented here, but based largely on mtDNA cytochrome *b* information; they suggest that KOD may have been colonized by bears from mainland western Alaska. However, Talbot and Shields (1996a) did not include samples from Kamchatka, so were unable to test Kurtén's (1973) hypothesis that bears of the Kodiak Archipelago are more closely allied to bears of Kamchatka than elsewhere in either Alaska or eastern Siberia. Our control region data lend little support for that hypothesis.

The presence of private haplotypes on KOD, and complete pairwise differentiation relative to the population on KAT (based on variance of allele and haplotype frequency), is suggestive of very low gene flow to and from mainland Alaskan populations.

Surprisingly, the most common haplotype on KOD is not found on AFOG, although the second most common haplotype, UARCR30, is shared between the two islands as well as with bears from eastern Siberia. UARCR30 differs from the most common KOD haplotype (UARCR9) by a single site substitution at position 287(C – T), and by a deletion in the 5' thymine T_n repeat array. That the most common haplotype on KOD is not present on AFOG can at least partially explain our results that frequency-only based F_{ST} measures of variance at mtDNA loci suggested significant differentiation between AFOG and KOD, yet this difference disappears upon invoking a model of evolution (Φ_{ST}).

Although our data suggest bears of the Kodiak Archipelago share recent evolutionary ancestry with bears on mainland Alaska, KAM and Siberia, AMOVA suggests that populations on the Kodiak Archipelago are experiencing very limited gene flow with mainland Alaskan bears. This is demonstrated by significant differentiation between KOD and KAT, and between AFOG and KAT, at microsatellite loci (data not shown for R-statistic analysis). Similarly, Kodiak Archipelago populations are significantly differentiated from all other populations examined in Alaska for mtDNA, whether a model of evolution is used or not (data not shown). This pattern reflects significant long-term geographic isolation of the populations on the Kodiak Archipelago, perhaps at least since the last glacial maximum. This pattern is also observed at the DQB1 exon 2 locus, which is under balancing selection (see below). The two alleles observed on the Kodiak Archipelago are not observed on the mainland population of KAT, suggesting isolation and perhaps different responses to past selection pressures on the protein binding region (PBR) of the MHC DQB1 exon 2 gene of the Kodiak Archipelago populations.

Biogeographic events resulting from Pleistocene glaciation and retraction are thought to have significantly influenced the generation of modern species diversity (Lovette 2005). The Pleistocene epoch was a time of dramatic oscillations of global climate, with unprecedented cycles of global cooling occurring about every 100,000 years and resulting in continental glaciation (Berger 1984). These ice ages were periodically interrupted by warming similar to conditions characterizing the Holocene (the last 10,000 years). The evolutionary histories of organisms in the northern latitudes were profoundly impacted by these glacial-interglacial cycles.

At least two unglaciated regions (refugia) were separated by full glacial advance in North America. One was the Beringian sub-continent, which joined North America and Asia, and one was in the lower latitudes, south of the reaches of glacial ice. Additional ice-free regions have

been hypothesized for the Pacific coast, mostly for the area currently known as the Alexander Archipelago in southeastern Alaska and British Columbia (e.g., Moodie and Reimchen 1976, O'Reilly et al. 1993, Heaton et al. 1996, Byun et al. 1997, 1999). Following the late Wisconsin glacial period, some mammals, such as wolves (Klein 1965), are thought to have repopulated Alaska from regions south of the glacial extent, since the glaciated coast range to the north and northeast presented a physical barrier to access from the interior of Alaska (Pedersen 1982). Other mammals, including caribou, moose and wolves isolated in the Beringian sub-continent, are thought to have expanded to the south, repopulating areas following the retreat of the ice.

Since Kodiak Island was glaciated during the Wisconsin period, it is likely that brown bears colonized Kodiak after glacial retreat some 10-12,000 years ago, although Kurtén (1973) suggests a refugium large enough to support plants may have existed on Kodiak Island. The mtDNA genetic data, however, are more consistent with a pattern of rapid expansion of populations from refugia on the Beringian sub-continent of Asia into a recently deglaciated region, followed by isolation and *de novo* mutations, rather than the existence of a Kodiak glacial refugium that subsequently remained isolated from the rest of western Beringia. In the latter case, we would expect to uncover deeper phylogenetic lineages rather than the shallow, starlike phylogeny characterizing haplotype relationships on the Kodiak Archipelago. We find no genetic evidence of expansion from a southern (continental United States) refugium, which would likely have resulted in the presence of haplotypes currently observed in the eastern Beringian and/or Alexander Archipelago clusters (Figure 2a, b), as observed for the same gene region assayed in Alaskan gray wolves (Weckworth et al. 2005).

Major Histocompatibility Genes: DQB1 Exon 2

A comparison of amino acid sequences showed polymorphism within the PBR of the ursid DQB1 exon 2 locus. The relative frequencies of nonsynonymous substitutions exceed that of synonymous substitutions in the ABS, suggesting observed allelic polymorphism in brown bears of Alaska is maintained by positive selection between populations (Hughes and Nei 1989). However, the differences observed between the two haplotypes found on Kodiak Island were not at ABS sites, and therefore the observed mutation may be neutral (see Seddon and Ellegren 2004). Mechanisms responsible for retaining polymorphism at MHC loci include overdominance, frequency-dependent selection (driven by pathogens), and disassortative (non-

random) mating (Potts et al. 1991). Levels of variation in our comparative regional samples of western Alaskan brown bears at both selected (DQB1 exon 2) and neutral (microsatellite loci, mtDNA) loci were similar and concordant, as has been reported for other species (Boyce et al. 1997, Hedrick et al. 2001, Landry and Bernatchez 2001). Thus, we find that low levels of variation at neutral nuclear markers reflect low levels of variation at a nuclear marker associated with fitness (in this case, disease resistance).

The major histocompatibility complex is a family of highly polymorphic genes encoding a set of transmembrane proteins critical to the generation of immune responses (Klein and Sato 2000a, b). These cell-surface glycoproteins play a key role in the initiation of immune response by binding foreign peptides and presenting them to T-cells (Klein and Sato 2000a,b). Polymorphism at MHC-encoded proteins ultimately determines the ability of the individuals to respond to infectious diseases. High levels of variation at class I and class II proteins is thought to be an adaptation to the large numbers of pathogens encountered by natural populations (Klein and Takahata 1990), and infectious disease epidemics may have played a central role in determining MHC allele frequencies observed in extant populations (Yuhki and O'Brien 1990). Genetic and antigenic diversity at the MHC may play an important role in an individual's ability to respond to rapidly-evolving infectious diseases that periodically sweep through natural populations. A lack of population-wide variation at the MHC and fixation at novel alleles relative to source populations may be the result of past differential pathogen pressure (Babik et al. 2005) and may increase susceptibility of isolated populations to infectious disease epidemics (Yuhki and O'Brien 1990). Because of the key role of MHC diversity in disease susceptibility, characterizing and understanding polymorphism at these genes is critical in the study of infectious disease ecology at the population level.

Genes within the MHC are divided into at least three major types (class I, II and III). Here we have characterized a locus within one of the three broad classes of MHC molecules, the class II molecules. Class II molecules primarily bind peptides from proteins originating outside of the cell, such as those produced by extracellular bacteria, and are expressed only on antigen presenting cells, such as macrophages. Class I genes code for proteins that bind peptides from proteins degraded in the cytosol, such as those produced during viral infections, and are present in all somatic cells. Class III molecules are structurally unrelated to class I and II molecules and are also unrelated to antigen presentation (Wagner et al. 1999). Although there is no class II

DQB sequence information publicly available for *U. arctos*, class II DQB gene information from the domestic dog (Sarmiento et al. 1992, 1993; Schreiber et al. 1998; Wagner et al. 1996a, b, 1999) show that the canine DQB gene products are polymorphic and may be important in generating peptide-binding diversity.

Our data suggest the levels of allelic diversity at the MHC class II DQB1 exon 2 gene within brown bears of the Kodiak Archipelago are much lower than levels observed in populations elsewhere in Alaska; however, only one mainland population (KAT) has been reasonably well-characterized. Low levels of variation at the MHC have been observed in populations that are also characterized by low levels of variation at neutral genetic markers attributable to severe recent demographic bottlenecks (Hoelzel et al. 1993, Bonnell and Selander 1994). Although the brown bears of the Kodiak Archipelago are characterized by low genetic variation at microsatellite loci, we found no signature of a recent demographic bottleneck (within the last 2 to 20 generations, G. Luikart pers. comm.) in either AFOG or KOD. Garza's M , however, was significantly lower than the critical value expected, consistent with longer term (over the past 100 generations) small effective population size (Garza and Williamson 2001). Although low levels of variation in the MHC in endangered species have been implicated in their response to infectious disease (O'Brien and Evermann 1988), it is not certain whether this effect necessarily applies to brown bears of the Kodiak Archipelago. Although high allelic diversity is thought to establish a stronger host defense and increase individual fitness (Hughes and Nei 1989, Takahata and Nei 1990), some studies have shown that species with low MHC diversity are still viable (Hoelzel et al. 1999, Mikko et al. 1999). The Kodiak Archipelago bears appear viable (USFWS 2002) and show no apparent phenotypic signs of inbreeding depression. Nevertheless, the populations on the Kodiak Archipelago may have a smaller chance at mounting immune responses against pathogens over the long term, given the low variability at the MHC class II DQB1 exon 2 gene. The DQB1 exon 2 alleles present within the Kodiak Archipelago are not found on Katmai (and vice versa), and these differences are at sites that are apparently under selection. This suggests the Archipelago populations have been subjected to a different selection regime since differentiation from mainland bears.

Conservation Implications

Although mtDNA haplotypes and microsatellite alleles are shared between Kodiak Archipelago bears and those in mainland Alaska populations, they occur at different frequencies and those differences are significant and indicative of genetic isolation. However, divergences are much more shallow than those observed among other Alaskan populations (Talbot and Shields 1996a, Waits et al. 1998, Paetkau et al. 1998a), and thus there is little support for currently hypothesized subspecies designation applied to bears of the Kodiak Archipelago. Nevertheless, the importance of the Linnean rank of subspecies to conservation policy is under critical appraisal (Zink 2003). Although Mayr (1970) suggested that subspecific variation represents local adaptation, Crandall et al. (2000) suggest the subspecies may reflect adaptive variation critical to the species' survival, regardless of pattern of mtDNA reciprocal monophyly. Because many subspecies that fail to exhibit reciprocal monophyly at the mtDNA genome, but exhibit geographic pattern in morphology (phenotypic variation) that may reflect local adaptations (probably important in the species' future survival), there appears to be a conflict between the use of a historical approach advocated by Zink (2003) and that advocated by Crandall et al. (2002; see Moritz 2002). Because phenotypic variation can evolve quite rapidly, but reciprocal monophyly of neutral markers requires much longer to evolve, restoration of historical groups would take much longer than the restoration of phenotypic variation characterizing subspecies (Moore and Atkins 2003). Zink (2003) argues that the preservation of reciprocally monophyletic groups and attendant "significant bouts of independent history" will concomitantly preserve adaptive phenotypic variation included in such groups (see Crokrak and Merila 2002). This debate is not new and will not be resolved in the near future.

Regardless of future resolution of operational criteria for delineation of subspecies, it is clear that Kodiak Archipelago brown bear populations are genetically isolated from mainland populations, and apparently genetically isolated from each other, although certainly more recently. Contemporary demographic independence may leave island populations more vulnerable to environmental disruptions, including habitat fragmentation or disease, particularly if those populations are characterized by low levels of variation at markers thought to be involved in immune response.

Genetic variation in neutral nuclear loci is so low on KOD and AFOG that it is unlikely that a suite of 14 microsatellite loci (of which only 12 are polymorphic in Kodiak Archipelago populations) are adequate to provide individual identification for genetic tagging studies on

AFOG or KOD. Even genes in the most variable portion of the MHC supergene (class II, exon 2 peptide-binding regions) are essentially monomorphic in Kodiak Archipelago populations. It is possible that additional markers can be added to this suite to boost exclusion probabilities, but such a large suite of loci may be impractical for robust genetic tagging studies due to technical considerations (Paetkau 2003).

Literature Cited

- Alaska Department of Fish and Game (2002) Kodiak Archipelago Bear Conservation and Management Plan. Alaska Department of Fish and Game, Anchorage, Alaska, Division of Wildlife Conservation. 240 pp.
- Altschul SF, TL Madden, AA Schäffer, J Zhang, Z Zhang, W Miller and DJ Lipman (1997) Gapped BLAST and PSI-BLAST: a new generation of protein database search programs. *Nucleic Acids Res.* **25**:3389-3402.
- Allendorf FW and RF Leary (1986) Heterozygosity and fitness in natural populations of animals. In: (ed. ME Soulé), *Conservation Biology: the Science of Scarcity and Diversity*, pp. 57-76. Sinauer Associates, Inc., New York.
- Allendorf FW, RB Harris and LH Metzgar LH (1991) Estimation of effective population size of grizzly bears by computer simulation. In: *Proceedings of the Fourth International Congress of Systematics and Evolutionary Biology*, pp. 650-654. Fourth Discords Press, Portland, OR.
- Apple R, C Weeler, T Becker, W Klitz and H Erlich (1993) HLA DR-DO disease associations in Hispanic cervical carcinoma. *Hum. Immunol.* **37**:62.
- Apple RJ, TL Bugawan, R Griffith, JD Chang and HA Erlich (1993) A new DRB1 allele and a novel DR4 haplotype found in a Filipino family. *Tissue Antigens* **41**(1): 51-54.
- Avise JC (2000) Phylogeography, the history and formation of species. Harvard University Press, Cambridge, United Kingdom.
- Babik W, W Durka and J Radwan (2005) Sequence diversity of the MHC DRB gene in the Eurasian beaver (*Castor fiber*). *Molecular Ecology* **14**:4249-4257.
- Barnes Jr. VG and RB Smith (1998) Estimates of brown bear abundance on Kodiak Island, Alaska. *Ursus* **10**:1-9.
- Belkhir K, V Castric and F Bonhomme (2002) IDENTIX, a software to test for relatedness in a population using permutation methods. *Mol. Ecol. Notes* **2**:611-614.
- Berger A (1984) Accuracy and frequency stability of the Earth's orbital elements during the Quarternary. In: (eds A Berger, J Imbrie, J Hays, G Kukla, B Salzmann) *Milankovitch and Climate, Part I*, pp. 527-537. Reidel: Dordrecht.

- Bonnell ML and RK Selander (1974) Elephant seals: genetic variation and near extinction. *Science* **184**:908-909.
- Bowen L, BM Aldridge, F Gulland, J Woo, W Van Bonn, R DeLong, JL Stott and ML Johnson (2002) Molecular characterization of expressed DQA and DQB genes in the California sea lions (*Zalophus californianus*). *Immunogenetics* **54**:332-347.
- Bowen L, BM Aldridge, F Gulland, W Van Bonn, R DeLong, S Melin, LJ Lowenstine, JL Stott and ML Johnson (2004) Class II multiformity generated by variable MHC-DRB region configurations in the California sea lion (*Zalophus californianus*). *Immunogenetics* **56**:12-27.
- Boyce WM, PW Hedrick, NE Muggli-Cockett, S Kalinowski, MC Penedo and RR Ramey (1997) Genetic variation of major histocompatibility complex and microsatellite loci: a comparison with bighorn sheep. *Genetics* **145**:421-433.
- Brown JH, TS Jardetzky, JC Gorda, LJ Stern, RG Urban, JL Stominger and DC Wiley (1993) Three-dimensional structure of the human class II histocompatibility antigen HLA-DR1. *Nature* **364**:33-39.
- Briles WE, HA Stone and RK Cole (1977) Marek's disease: effects of B histocompatibility alloalleles in resistant and susceptible chicken lines. *Science* **195**:193-195.
- Byun SA, BF Koop and TE Reimchen (1997) North American black bear mtDNA phylogeography: implication for morphology and the Haida Gwaii glacial refugium controversy. *Evolution* **51**:1647-1653.
- Byun SA, BF Koop and TE Reimchen (1999) Coastal refugia and postglacial recolonization routes: a reply to Demboski, Stone, and Cook. *Evolution* **53**:2013-2015.
- Carrington MG, W Nelson, MP Martin, T Kissner, D Vlahov, JJ Goedert, R Kaslow, S Buchbinder, K Hoots and SJ O'Brien (1999) *HLA* and *HIV-1*: heterozygote advantage and *B*35-C2*04* disadvantage. *Science* **238**:1748-1752.
- Casane D, N Dennebouy, H DeRochambeau, JC Mounolou and M Monnerot (1997) Nonneutral evolution of tandem repeats in the mitochondrial DNA control region of Lagomorphs. *Mol. Biol. Evol.* **14**:779-789.
- Cavalli-Sforza LL and AWF Edwards (1967) Phylogenetic analysis: models and estimation procedures. *Evolution* **21**:550-570.

- Cornuet J-M and G Luikart (1996) Description and power analysis of two tests for detecting recent population bottlenecks from allele frequency data. *Genetics* **144**:2001-2014.
- Craighead FL, D Paetkau, HV Reynolds, C Strobeck and ER Vyse (1998) Use of microsatellite DNA analysis to infer breeding behavior and demographic processes in an Arctic grizzly bear population. *Ursus* **10**:323-327.
- Crandall KA, ORP Bininda-Emonds, GM Mace and RK Wayne (2000) Considering evolutionary processes in conservation biology. *Trends Ecol. Evol.* **15**:290-295.
- Crokrak P and J Merila (2002) Genetic population divergence: markers and trait. *Trends Ecol. Evol.* **17**:501.
- Di Rienzo A, AC Peterson, JC Garza, AM Valdes, M Slatkin and NB Freimer (1994) Mutational processes of simple-sequence repeat loci in human populations. *Proc. Natl. Acad. Sci. USA* **91**:3166-3170.
- Edwards SV and PW Hedrick (1998) Evolution and ecology of MHC molecules: from genomics to sexual selection. *TREE* **13**:305-311.
- El Mousadik A and RJ Petit (1996) High level of genetic differentiation for allelic richness among populations of the argan tree [*Argania spinosa* (L.) Skeels] endemic of Morocco. *Theor. App. Gen.* **92**:832-839.
- Excoffier L, PE Smouse and JM Quattro (1992) Analysis of molecular variance inferred from metric distances among DNA haplotypes: Application to human mitochondrial DNA restriction data. *Genetics* **131**:479-491.
- Fleming MD and P Spencer (2004) Covertypes descriptions of Kodiak Archipelago. USGS in-house report. USGS Alaska Science Center, Geography Branch, Anchorage, AK. 65 pp.
- Freimer NB and M Slatkin (1996) Microsatellites: evolution and mutational processes. *Ciba Found. Symp.* **197**:51-72.
- Fu Y-X (1997) Statistical tests of neutrality of mutation against population growth, hitchhiking and background selection. *Genetics* **147**:915-925.
- Garza JC and Williamson (2001) Detection of reduction in population size when using data from microsatellite loci. *Molecular Ecology* **10**:305-318.
- Goudet J (1995) FSTAT(ver 1.2): A computer program to calculate F-statistics. *J. Hered.* **86**:485-486.

- Goudet J (2001) FSTAT, a program to estimate and test gene diversities and fixation indices (version 2.9.3). Available from <http://www.unil.ch/izea/software/fstat.html>. Updated from Goudet (1995)
- Grant WS and BW Bowen (1998) Shallow population histories in deep evolutionary lineages of marine fishes: insights from sardines and anchovies and lessons for conservation. *Journal of Heredity* **89**:445-426.
- Hall ER (1984) Geographic variation among brown and grizzly bears (*Ursus arctos*) in North America. University of Kansas Museum of Natural History Special Publication Vol 13.
- Hancock JM (1999) Microsatellites and other simple sequences: genomic context and mutational mechanisms. In: (Eds. DB Goldstein, C Schlotterer) *Microsatellites: Evolution and Applications*, pp. 1-9. Oxford University Press.
- Hansson B and L Westerberg (2002) On the correlation between heterozygosity and fitness in natural populations. *Molecular Ecology* **11**:2467-2474.
- Harley EH (2002) AGARst: a program for calculating allele frequencies, G_{st} and R_{st} from microsatellite data plus a number of other population genetic estimates and outputting files formatted for various other population genetic programs, <http://web.uct.ac.za/dept/chempath/genetic/htm>.
- Hasegawa M, K Kishino and T Yano (1985) Dating the human-ape splitting by a molecular clock of mitochondrial DNA. *Journal of Molecular Evolution* **22**:160-174.
- Hayasaka K, T Ishida and S Horai (1991) Heteroplasmy and polymorphism in the major noncoding region of mitochondrial DNA in Japanese monkeys: association with tandemly repeated sequences. *Molecular Biology and Evolution* **14**:779-789.
- Heaton TH, SL Talbot and GF Shields (1996) An ice age refugium for large mammals in the Alexander Archipelago, southeastern Alaska. *Quaternary Research* **46**:186-192.
- Hedrick PW, GA Gutierrez-Espeleta and RN Lee (2001) Founder effect in an island population of bighorn sheep. *Molecular Ecology* **10**:851-857.
- Hewitt GM (1996) Some genetic consequences of ice ages, and their role in divergence and speciation. *Biological Journal of the Linnean Society*, **58**:247-276.
- Hill AVS, CEM Allson, D Kwiatkowski, NM Anstey, P Twunasi, PA Rowe, S Bennett, D Brewster, AJ McMichael and BM Greenwood (1991) Common West African HLA antigens are associated with protection from severe malaria. *Nature* **352**:595-600.

- Hoelzel AR, J Halley, SJ O'Brien, C Campagna, T Arnbom, J Le Boeuf, K Ralls and GA Dover (1993) Elephant seal genetic variation and the use of simulated models to investigate historical bottlenecks. *Journal of Heredity* **84**:443-449.
- Hoelzel AR, JV Lopez, GA Dover and SJ O'Brien (1994) Rapid evolution of a heteroplasmic repetitive sequence in the mitochondrial DNA control region of carnivores. *Journal of Molecular Evolution* **39**:191-199.
- Hoelzel AR, J Stephens and SJ O'Brien (1999) Molecular genetic diversity and evolution at the MHC DQB locus in four species of pinnipeds. *Molecular Biology and Evolution* **16**:611-618.
- Hughes AL and M Nei (1989) Nucleotide substitution at major histocompatibility complex class II loci, evidence for overdominant selection. *Proceedings of the National Academy of Sciences USA* **86**:958-962.
- Jackson JV, SL Talbot and S Farley (2005) Genetic characterization of Kenai brown bears (*Ursus arctos*): microsatellite and mitochondrial DNA control region variation in brown bears of the Kenai Peninsula, southcentral Alaska. *Conservation Genetics*: in review.
- Jukes TH and CR Cantor (1969) Evolution of protein molecules. Pp. 21-132 In. Munro HM (ed.) *Mammalian Protein Metabolism*. Academic Press, NY.
- Kimura M (1980) A simple method for estimating evolutionary rates of base substitutions through comparative studies of nucleotide sequences. *Journal of Molecular Evolution* **16**:111-120.
- Klein DR (1965) Post glacial distribution patterns of mammals in the southern coastal regions of Alaska. *Arctic* **10**:7-10.
- Klein J and A Sato (2000a) The HLA system: first of two parts. *New England Journal of Medicine* **343**:702-709.
- Klein J and A Sato (2000b) The HLA system: second of two parts. *New England Journal of Medicine* **343**:789-786.
- Klein J and N Takahata (1990) The major histocompatibility complex and the quest for origins. *Immunological Reviews* **113**:5-26.
- Kumar S, TK Koichiro, IB Jakobsen and M Nei (2001) MEGA2: molecular evolutionary genetics analysis software. *Bioinformatics* **17**:1244-1245.

- Kurtén B (1973) Transberingian relationships of *Ursus arctos* Linné (brown and grizzly bears) *Commentat. Biol.* **65**:1-10.
- Landry C and L Bernatchez (2001) Comparative analysis of population structure across environments and geographical scales at major histocompatibility complex and microsatellite loci in Atlantic salmon (*Salmo salar*). *Molecular Ecology* **10**:2525-2539.
- Levinson G and GA Gutman (1987) Slipped strand mispairing: a major mechanism for DNA sequence evolution. *Molecular Biology and Evolution* **4**:203-221.
- Li CC and DG Horovitz (1953) Some methods for estimating the inbreeding coefficient. *American Journal of Human Genetics* **5**:107-117.
- LI-COR (1999) Sequencing Protocols. Section 4 in: DNA Sequencing Manual: Global Edition, IR2 System. Lincoln, Nebraska.
- Lovette I (2005) Glacial cycles and the tempo of avian speciation. *Trends in Ecology and Evolution* **20**:57-59.
- Luikart G and J-M Cornuet (1998) Empirical evaluation of a test for identifying recently bottlenecked populations from allele frequency data. *Conservation Biology* **12**:228-237.
- Lunt DH, LE Whipple and BC Hyman (1998) Mitochondrial DNA variable number of tandem repeats (VNTRs): utility and problems in molecular ecology. *Molecular Ecology* **7**:1441-1455.
- Madsen CS, SC Ghivizzani and WW Hauswirth (1993) *In vivo* and *in vitro* evidence for slipped mispairing in mammalian mitochondria. *Proceedings of the National Academy of Sciences USA* **90**:7671-7675
- Maruyama T and PA Fuerst (1985) Population bottlenecks and nonequilibrium models in population genetics. II. Number of alleles in a small population that was formed by a recent bottleneck. *Genetics* **111**:675-689.
- Matsushashi T, R Masuda, T Mano and C Yoshida (1999) Microevolution of the mitochondrial DNA control region in the Japanese brown bear (*Ursus arctos*) population. *Molecular Biology and Evolution* **16**:676-684.
- Mayr E (1970) *Populations, Species and Evolution*. Belknap, Cambridge MA.
- McElroy D, P Moran, E Bermingham and I Kornfield (1991) REAP: The Restriction Enzyme Analysis Program, Version 4.0. Dept. Zool., Univ. Maine, Orono, ME.

- Medrano JF, E Aasen and J Sharrow (1990) DNA extraction from nucleated red blood cells. *Biotechniques* **8**:43.
- Mikko S, K Roed, S Schmutz and L Andersson (1999) Monomorphism and polymorphism at MHC DRB loci in domestic and wild ruminants. *Immunological Reviews* **167**:169-178.
- Miller S and J Schoen (1999) Brown bear conservation action plan for North America. In: (eds. S Herrero, B Peyton) *Bears – Status survey and conservation action plan: ICUM/SSC bear and polar bear specialist groups*, Chapter 6. Gland, Switzerland.
- Moodie GEE and TE Reimchen (1976) Glacial refugia, endemism and stickleback populations of the Queen Charlotte Islands. *Canadian Field Naturalist* **90**:471-474.
- Mooers AØ and RA Atkins (2003) Indonesia's threatened birds: over 500 years of evolutionary heritage at risk. *Animal Conservation* **6**:183-188.
- Moritz C (2002) Strategies to protect biological diversity and the processes that sustain it. *Systematic Biology* **51**:238-254.
- Nei M and T Gojobori (1986) Simple methods for estimating the numbers of synonymous and nonsynonymous nucleotide substitutions. *Molecular Biology and Evolution* **3**:418-426.
- Nei M (1987) *Molecular Evolutionary Genetics*. New York: Columbia University Press.
- Nei M, T Maruyama and R Chakraborty (1975) The bottleneck effect and genetic variability in populations. *Evolution* **29**:1-10.
- Ohta T and K Kimura (1973) The model of mutation appropriate to estimate the number of electrophoretically detectable alleles in a genetic population. *Genetical Research* **22**:201-204.
- O'Brien SJ and JF Evermann (1988) Interactive influence of infectious disease and genetic diversity in natural population. *Trends in Ecology and Evolution* **3**:254-259.
- O'Reilley P, TE Reimchen, R Beech and C Strobeck (1993) Mitochondrial DNA in *Gasterosteus* and Pleistocene glacial refugium on Queen Charlotte Islands, British Columbia. *Evolution* **47**:678-694.
- Ostrander EA, GF Sprague and J Rine (1993) Identification and characterization of di-nucleotide repeat (CA)_n markers for genetic mapping in dog. *Genomics* **167**:207-213.
- Paetkau D, W Calvert, I Stirling and C Strobeck (1995) Microsatellite analysis of population structure in Canadian polar bears. *Molecular Ecology* **4**:347-354.

- Paetkau D, GF Shields and C Strobeck (1998a) Gene flow between insular, coastal and interior populations of brown bears in Alaska. *Molecular Ecology* **7**:1283-1292.
- Paetkau, D, LP Waits, PL Clarkson, L Craighead and C Strobek (1998b) Dramatic variation in genetic diversity across the range of North American brown bears. *Conservation Biology* **12**:418-429.
- Paetkau D (2003) An empirical exploration of data quality in DNA-based population inventories. *Molecular Ecology* **12**:1375-1387.
- Park SDE (2001) Trypanotolerance in west African cattle and the population genetics effects of selection. Ph. D. thesis, University of Dublin.
- Paterson S, K Wilson and JM Pemberton (1998) Major histocompatibility complex variation associated with juvenile survival and parasitic resistance in a large unmanaged ungulate population (*Ovis ares* L.). *Proceedings of the National Academy of Sciences. USA* **95**:3714-3719.
- Pedersen S (1982) Geographical variation in Alaskan wolves. In: (eds. FH Harrington, PC Paquet) *Wolves of the World*, pp. 334-344. Noyes Publishers, Park Ridge, NJ.
- Piry S, G Luikart and J-M Cornuet (1999) BOTTLENECK: A computer program for detecting recent reductions in the effective population size using allele frequency data. *Journal of Heredity* **90**:502-503.
- Posada D and KA Crandall (1998) Modeltest: testing the model of DNA substitution. *Bioinformatics* **14**:817-818.
- Potts WK, CJ Manning and EK Wakeland (1991) Mating patterns in seminatural populations of mice influenced by MHC genotype. *Nature* **352**:619-621.
- Pritchard JK, M Stephens and P Donnelly (2000) Inference of population structure using multi locus genotype data. *Genetics* **155**:945-959.
- Queller DC and KF Goodnight (1989) Estimating relatedness using genetic markers. *Evolution* **43**:258-275.
- Rausch RL (1963) Geographic variation in size in North American brown bears, *Ursus arctos* L. as indicated by condylobasal length. *Canadian Journal of Zoology*. **41**:33-45.
- Raymond M and F Rousset (1995) GENEPOP (Ver 1.2): population genetics software for exact tests and ecumenicism. *Journal of Heredity* **86**:248-249.

- Reynolds JB, S Weir and CC Cockerham (1983) Estimation of the coancestry coefficient: basis for short term genetic distance. *Genetics* **105**:767-779.
- Rice WR (1989) Analyzing tables of statistical tests. *Evolution* **43**:223-225.
- Roff DA and P Bentzen (1989) The statistical analysis of mitochondrial DNA polymorphism: χ^2 and the problem of small samples. *Mol. Biol. Evol.* **6**:539-545.
- Rogers LL (1987) Effects of food supply and kinship on social behavior, movements, and population growth of black bears in northeastern Minnesota. *Wildlife Monographs* **97**:1-72.
- Sarmiento UM, S DeRose, JI Sarmiento and R Storb (1992) Allelic variation in the DQ subregion of the canine major histocompatibility complex: I. DQA. *Immunogenetics* **35**:416-420.
- Sarmiento UM, S DeRose, JI Sarmiento and R Storb (1993) Allelic variation in the DQ subregion of the canine major histocompatibility complex: 2. DQB. *Immunogenetics* **37**:148-152.
- Sarmiento UM, JI Sarmiento and R Storb (1990) Allelic variation in the DR subregion of the canine major histocompatibility complex. *Immunogenetics* **32**:13-19.
- Schneider S, D Roessli and L Excoffier (2000) Arlequin ver. 2.000: a software for population genetics data analysis. Genetics and Biometry Laboratory, University of Geneva, Switzerland. Available: <http://anthropologie.unige.ch/arlequin>.
- Schreiber A, K Eulenberger and K Bauer (1998) Immunogenetic evidence for the phylogenetic sister group relationships of dogs and bears (Mammalia, Carnivora: Canidae and Ursidae), a comparative determinant analysis of carnivoran albumin, c3 complement and immunoglobulin micro-chain. *Experimental and Clinical Immunogenetics* **15**:154-170.
- Schwartz CC and AW Franzmann (1992) Dispersal and survival of subadult black bears from the Kenai Peninsula, Alaska. *Journal of Wildlife Manage.* **56**:426-431.
- Seddon JM and H Ellegren (2002) MHC class II genes in European wolves: a comparison with dogs. *Immunogenetics* **54**:490-500.
- Seddon JM and H Ellegren (2004) A temporal analysis shows MHC loci in the Scandinavian wolf population are consistent with neutral evolution. *Proceedings of the Royal Society London, Series B* **271**: 2283-2291.

- Shi J, TL Blundell and K Mizuguchi (2001) FUGUE: sequence-structure homology recognition using environment-specific substitution tables and structure-dependent gap penalties. *Journal of Molecular Biology* **310**:243-257.
- Slatkin M (1995) A measure of population subdivision based on microsatellite allele frequencies. *Genetics* **139**:457-462.
- Spencer CC, JE Neigel and PL Leberg (2000) Experimental evaluation of the usefulness of microsatellite DNA for detecting demographic bottlenecks. *Molecular Ecology* **9**:1517-1528.
- Stoneking M (2000) Hypervariable sites in the mtDNA control region are mutational hotspots. *Am. J. Hum. Genet.* **67**:1029-1032.
- Swofford DL (2000) PAUP*: Phylogenetic Analysis Using Parsimony (*and other methods). Version 4. Sinauer Associates, Sunderland, Mass.
- Swofford DL and RB Selander (1981) BIOSYS-1: A FORTRAN program for the comprehensive analysis of electrophoretic data in population genetics and systematics. *Journal of Heredity* **72**:281-283.
- Taberlet P, JJ Camarra and S Griffin (1997) Non-invasive genetic tracking of the endangered Pyrenean brown bear population. *Molecular Ecology* **6**:869-876.
- Tae KE (1997) Processes controlling the range expansion of Sitka spruce on Kodiak Island, Alaska. M.S. Thesis, University of Alaska Fairbanks, Fairbanks, AK.
- Tajima F (1983) Evolutionary relationship of DNA sequences in finite populations. *Genetics* **105**:437-460.
- Tajima F (1989) The effect of change in population size on DNA polymorphism. *Genetics* **123**:597-601.
- Takahata N and M Nei (1990) Allelic genealogy under overdominant selection and frequency-dependent selection and polymorphism of major histocompatibility complex loci. *Genetics* **124**:967-978.
- Takezaki N and M Nei (1996) Genetic distances and reconstruction of phylogenetic trees from microsatellite DNA. *Genetics* **144**:389-399.
- Talbot SL and GF Shields (1996a) Phylogeography of brown bears (*Ursus arctos*) of Alaska and paraphyly within the Ursidae. *Molecular Phylogenetics and Evolution* **5**:477-494.

- Talbot SL and Shields GF (1996b) A phylogeny of the bears (Ursidae) inferred from complete sequences of three mitochondrial genes. *Molecular Phylogenetics and Evolution* **5**:567-575.
- Tamura K and M Nei (1989) Positive Darwinian selection observed at the variable-region genes of immunoglobulins. *Molecular Biology and Evolution* **6**:447-459.
- Tamura K and M Nei (1993) Estimation of the number of nucleotide substitutions in the control region of mitochondrial DNA in humans and chimpanzees. *Molecular Biology and Evolution* **10**:512-526.
- Thursz MR, HC Thomas, BM Greenwood and AVS Hill (1997) Heterozygote advantage for HLA class-II type in hepatitis E virus infection. *Nat. Genet.* **17**:11-12.
- U. S. Fish and Wildlife Service (2004) Draft Revised Comprehensive Conservation Plan and Environmental Impact Statement for Kodiak National Wildlife Refuge. U. S. Fish and Wildlife Service, Anchorage, AK.
- Valieré N (2002) GIMLET: a computer program for analyzing genetic individual identification data. *Molecular Ecology Notes* **2**:377-379.
- Van Daele LJ (2003) *The History of Bears on the Kodiak Archipelago*. Anchorage, Alaska: Alaska Natural History Association. 83 pp.
- Wagner JL, R Burnett and R Storb (1996a) Molecular analysis of the DLA DR region. *Tissue Antigens* **48**:549-553.
- Wagner JL, RC Burnett, JD Works and R Storb (1996b) Molecular analysis of DLA-DRBBI polymorphism. *Tissue Antigens* **48**:554-561.
- Wagner JL, R Burnett and R Storb (1999) Organization of the canine major histocompatibility complex; current perspectives. *Journal of Heredity* **90**:35-38.
- Waits LP, SL Talbot, RH Ward and GF Shields (1998) Mitochondrial DNA phylogeography of the North American brown bear and implications for conservation. *Conservation Biology* **12**:408-417.
- Waits LP, G Luikart and P Taberlet (2001) Estimating the probability of identity among genotypes in natural populations: cautions and guidelines. *Molecular Ecology* **10**:249-256.
- Wakely J (1993) Substitution rate variation among sites in hypervariable region 1 of human mitochondrial DNA. Ph.D. dissertation, University of California, Berkeley.

- Weckworth BV, SL Talbot and JA Cook (2005) Tracking wolves (*Canis lupus*) across North America with signatures of genetic footprints. *Journal of Evolutionary Biology*: in review.
- Weir BS and CC Cockerham (1984) Estimating F-statistics for the analysis of population structure. *Evolution* **38**:1358-1370.
- Wilkinson GS and AM Chapman (1991) Length and sequence variation in evening bat D-loop mtDNA. *Genetics* **128**:607-617.
- Wobeser G (2002) Disease management strategies for wildlife. *Rev. Sci. Tech. Off. Int. Epiz.*, **21**:159-178.
- Woodford MH and PB Rossiter (1994) Disease risks associated with wildlife translocation projects. In: (eds. GM Mace, ATC Feistner) *Creative Conservation: Interactive Management of Wild and Captive Animals*, pp. 178-200. Chapman and Hall, London, United Kingdom.
- Wright S (1951) The genetical structure of populations. *Annals of Eugenics* **15**:323-354.
- Yuhki N and S O'Brien (1990) Nature and origin of polymorphism in feline MHC class II *DRA* and *DRB* genes. *Journal of Immunology*. **158**:2822-2833.
- Xu A, MJT Van Eijk, C Park and HA Lewin (1993) Polymorphism on *Bo LA-DRB3* exon 2 correlates with resistance to persistent lymphocytosis caused by bovine leukemia virus. *Journal of Immunology* **151**:6977-6985.
- Zink RM (2003) The role of subspecies in obscuring avian biological diversity and misleading conservation policy. *Proceedings of the Royal Society London, Series B* **271**:561-564.

Figure Legends

FIGURE 1. Sample locations. Distribution of samples on Kodiak and Afognak Island characterized at: a) nuclear microsatellite loci, b) the mtDNA control region, and c) the MHC class II DQBI exon 2 gene.

FIGURE 2. Distance (minimum evolution, neighbor-joining) tree describing evolutionary relationships among 45 haplotypes resolved on the basis of sequence information from a 589-592 bp fragment of the mitochondrial DNA genome encompassing portions of the cytochrome *b*

gene, the tRNA-pro, tRNA-thr genes, and a portion of the hypervariable domain I of the control region. Pairwise haplotypic relationships are based on the Hasegawa et al. (1985) model incorporating a gamma distribution of 0.4796. a) traditional phenogram, rooted using haplotypes found in the Alexander Archipelago; bootstrap values exceeding 50%, based on 1000 replicates, are given at the nodes, and populations in which haplotypes are found are listed to the right; b) radiation tree illustrating the same relationships, without rooting. Population designators are: [Alexander Archipelago: ADM = Admiralty Island; CHI = Chichagof Island; BAR = Baranof Island] [Eastern and Western Beringia: ANWR = Arctic National Wildlife Refuge; INT = Fairbanks area; BR = Brooks Range; AKR = Alaska Range; SCOA = southcoastal Alaska; KAT = Katmai National Park; IZE = Izembek National Wildlife Refuge; SCEN = southcentral Alaska; KOD = Kodiak Island; AFOG = Afognak Island; SPEN = Seward Peninsula; KAM = Kamchatka, Russia; ESIB = Eastern Siberia/Sea of Okhotsk/Magadan, Russia].

FIGURE 3. Neighbor-joining tree based on Cavalli-Sforza and Edward's (1967) chord distances, based on 12 nuclear microsatellite loci. Values on branches are bootstrap values based on 3000 permutations.

FIGURE 4. Neighbor-joining tree based on the coancestry coefficient (Reynolds et al. 1983), using mtDNA sequence data. Label designations: AFOG = Afognak; BR = Brooks Range; IZE = Izembek National Wildlife Refuge; KAM = Kamchatka, Russia; KAT = Katmai National Park; KOD = Kodiak; SCEN = Southcentral Alaska; SPEN = Seward Peninsula.

FIGURE 5. Nucleotide sequence identity between *Ursus arctos* class II MHC DQB1 exon 2 clones (*Urar*DQB1) and human, canine, elephant seal and other DQB sequences. Abbreviations for individual species MHC molecules are as follows: *Urar* = brown bear (*Ursus arctos*; this study); *Zaca*-DQB = elephant seal (*Zalophus californianus*; GenBank Accession No. AF503407; Bowen et al. 2002); *Calu*-DQB1 = wolf (*Canis lupus*; GenBank Accession No. AY126652; Seddon and Ellegren 2002); *HLA*-DRB1 = human MHC DRB1 exon 2 gene (GenBank Accession No. M84188; Apple et al. 1993); *Urma*-DRB = polar bear DRB1 exon 2 (*Ursus maritimus*; GenBank Accession No. AF458914; Wei and Happ, unpublished data); *HLA*-DQB2 = human MHC DQB2 exon 2 gene (GenBank Accession No. M83891; Kimura 1991). The

complete sequence of *Uar*DQB1*001 is shown. Single letters and dots below the nucleotide sequence represent nucleotides that are, respectively, distinct from or identical to *Uar*DQB1*001. The allelic numbers for the brown bear are assigned according to multispecies guidelines (Klein et al. 1990), with the assumption of a single DQB1 lineage based on close sequence homology between individual clones.

FIGURE 6. Alignment of amino acid sequences from the 10 sequences of MHC class II DQB1 exon 2 alleles of *Ursus arctos*, given in Figure 5. Sequence similarity to *Urar*DQB1*001 is indicated by a dot, while amino acid changes are represented by single letter codes. An asterisk indicates putative sites involved in peptide binding (ABS) as determined by Brown et al. 1993.

FIGURE 7. Neighbor-joining tree for brown bear sequences from the class II MHC DQB1 exon 2 gene, and outgroup sequences [Zaca = elephant seal (*Zalophus californianus*; GenBank Accession No. AF503407; Bowen et al. 2002); Calu = wolf (*Canis lupus*; GenBank Accession No. AY126652; Seddon and Ellegren 2002); Urma = polar bear (*Ursus maritimus*; GenBank Accession No. AF458914; Wei and Happ, unpublished data); HumanDRB1-1105 = human MHC DRB1 exon 2 gene (GenBank Accession No. M84188; Apple et al. 1993); HumanDQB2 = human MHC DQB2 exon 2 gene (GenBank Accession No. M83891; Kimura 1991)]. The numbers indicate bootstrap values for internal nodes. Distances are based on the Tamura-Nei model (Tamura and Nei 1993).

FIGURE 8. Distribution of brown bear mtDNA control region haplotypes for females only. Pie charts represent frequencies of each haplotype within the specific hunt areas.

Table 1. A description of 14 microsatellite loci and summary of allelic variation among three populations of brown bears (*U. arctos*) in Alaska (AFOG, KOD, KAT) and one in Kamchatka, Russia (KAM).

Locus ID	Na ¹	Size Range ²	AFOG (n = 29)			KOD (n = 218)			KAT (n = 29)			KAM (n = 11)		
			\underline{H}_E ³	\underline{H}_O ⁴	\underline{P} ⁵	\underline{H}_E	\underline{H}_O	\underline{P}	\underline{H}_E	\underline{H}_O	\underline{P}	\underline{H}_E	\underline{H}_O	\underline{P}
G1A	6	184-194	0.353	0.345	3	0.657	0.594*	3	0.639	0.448*		0.615	0.727	5
G10B	9	140-164	0.132	0.138	3	0.047	0.048	2	0.671	0.767		0.827	0.909	7
G10C	6	201-211	0.440	0.345	3	0.502	0.488	2	0.752	0.767		0.558	0.636	3
G1D	10	172-176	0.373	0.414	2	0.414	0.411	3	0.850	0.967		0.697	0.636	4
G10H	11	221-259	0.000	0.000	1	0.000	0.000	1	0.788	0.767		0.532	0.545	6
G10J	6	178-200	0.448	0.379	2	0.494	0.425*	2	0.669	0.667		0.645	0.364*	5
G10L	8	147-175	0.131	0.138	2	0.038	0.039	2	0.722	0.633		0.745	0.818	6
G10M	6	206-216	0.000	0.000	1	0.000	0.000	1	0.728	0.633		0.519	0.636	4
G10P	8	133-161	0.494	0.621	2	0.465	0.431	3	0.605	0.533		0.701	0.727	5
G10X	8	129-149	0.131	0.138	2	0.060	0.053	2	0.578	0.600		0.840	0.909	7
Uarμ26	9	170-192	0.068	0.069	2	0.374	0.373	5	0.689	0.667		0.723	1.000	7
Uarμ50	11	106-138	0.533	0.414	3	0.056	0.048*	3	0.768	0.733		0.714	0.636	7
UaCμ59	10	227-249	0.321	0.321	2	0.426	0.426	5	0.699	0.600		0.788	0.818	6
CXX203	8	104-124	0.354	0.310	2	0.389	0.370	5	0.769	0.700		0.818	0.727	5
Mean			0.270	0.259		0.280	0.263		0.709	0.677		0.694	0.721	
SE			0.050	0.049		0.062	0.058		0.020	0.033		0.029	0.044	

¹total number of alleles/haplotypes found among the populations and groups studied

²size range in base pairs for microsatellite loci, including primers

³expected heterozygosity (Nei 1987; eq. 7.39, pg. 164)

⁴observed heterozygosity

⁵total number of alleles found within population or group

*significant deviation from HWE

Table 2. Genetic variation at 14 microsatellite loci and mtDNA control region within populations of *U. arctos* of the Kodiak Archipelago (AFOG, KOD) and Katmai NP (KAT), Alaska, and Kamchatka Peninsula, Russia (KAM).

POPULATION	Microsatellites									mtDNA					
	P ¹	N ²	A ³	r _e ⁴	PA ⁵	H _O ⁶	H _E ⁷	F ⁸	R (var) ⁹	N ²	K ¹⁰	h (var) ¹¹	π (var) ¹²	D ¹³	F _S ¹⁴
AFOG	78.57	29	2.14	2.01	1	0.259	0.270	0.041	-0.034 (0.133)	28	1	0.069 (0.063)	0.0000 (0.000)	0.000	ns
KOD	57.14	218	3.14	2.26	5	0.263	0.280	0.061	-0.005 (0.109)	124	7	0.717 (0.187)	0.0001 (0.0002)	-1.2*	-14.05*
KAT	100.00	29	5.57	4.86	22	0.677	0.709	0.045	-0.098 (0.035)	41	8	0.605 (0.079)	0.0009 (0.001)	-1.02*	-6.32*
KAM	100.00	11	5.50	5.56	24	0.721	0.694	-0.039	-0.035 (0.047)	6	4	0.800 (0.172)	0.0020 (0.002)	-0.45	-1.45*

¹Percentage of polymorphic loci (0.95 criterion)

²number of individuals sampled

³average number of alleles at 14 microsatellite loci

⁴allelic richness (El Mousadik and Petit 1996)

⁵number of private alleles

⁶observed heterozygosity

⁷unbiased expected heterozygosity (Nei 1987; eq. 7.39, pg. 164)

⁸inbreeding coefficient (Wright 1951)

⁹R (var) = relatedness and variance (Queller and Goodnight 1989) based on the 12 polymorphic loci.

¹⁰number of mtDNA haplotypes

¹¹h (var) = haplotype diversity (Nei 1987; eq. 8.4, p. 178) and variance of h (Nei 1987; eq. 8.12, p. 180)

¹²π (var) = nucleotide diversity (Nei 1987, eq. 10.4, p. 257) and variance of π (Tajima 1983)

¹³Tajima's D (Tajima 1989)

¹⁴Fu's F_S (Fu 1997)

Table 3. Distribution of mtDNA control region haplotypes among brown bears of AFOG, KOD, KAT and KAM.

Haplotype	Position	Number of Haplotypes per Population			
		AFOG	KOD	KAT	KAM
	022333333344445				
	868133333634585				
	737523457664076				
UARCR9	ACCTTTT-CCACGAA	-	43	2	-
UARCR20--.....	-	26	-	-
UARCR21	..T.....G.	-	-	23	-
UARCR22	.TT.....	-	-	2	-
UARCR23--.....G.	-	-	1	-
UARCR24	..TC.....G.	-	-	1	-
UARCR28	.TT.....	-	-	2	-
UARCR30	..T.....	28	42	-	-
UARCR32--.....	1	7	-	-
UARCR33	G.....T.....	-	2	-	-
UARCR34T.....	-	2	-	-
UARCR35T-.....	-	2	-	-
UARCR36	..T.....G.	-	-	7	-
UARCR37	..T.....G.	-	-	1	-
UARCR38	..T.....	-	-	2	-
UARCR39--.....A.G	-	-	-	3
UARCR40--.....G...G	-	-	-	1
UARCR41--.....G	-	-	-	1
UARCR42--.....TA.G	-	-	-	1

Table 4. Pairwise measures of mtDNA and microsatellite differentiation. Above diagonal: Φ_{ST} (Excoffier et al. 1992), based on the HKY+I+ Γ model of site substitution (Hasegawa et al. 1985). Below diagonal: θ (Weir and Cockerham 1984) across nine microsatellite loci that conform to HWE expectations in all populations (see text). Values significantly different from zero are shown in bold face ($P < 0.05$; θ values adjusted by a sequential Bonferroni correction).

	AFOG	KOD	KAT	KAM
1 AFOG	-	-0.012	0.843	0.891
2 KOD	0.116	-	0.905	0.933
3 KAT	0.348	0.409	-	0.838
4 KAM	0.444	0.469	0.176	-

Table 5. Wilcoxon tests for heterozygosity in four populations of brown bear (*U. arctos*).

Values for heterozygote excess are based on 9 microsatellite loci. Values in bold are significant at $P < 0.05$, Bonferroni correction applied.

Population (N) ¹	WILCOXON TEST					
	IAM ³		TPM ³		SMM ³	
	<u>H² excess</u>	<u>H deficit</u>	<u>H excess</u>	<u>H deficit</u>	<u>H excess</u>	<u>H deficit</u>
AFOG (58)	0.248	0.787	0.545	0.500	0.715	0.326
KOD (418)	0.674	0.367	0.986	0.018	0.998	0.002
KAT (60)	0.018	0.988	0.469	0.594	0.711	0.344
KAM (22)	0.014	0.990	0.102	0.918	0.589	0.456

¹Number of alleles compared

²Ratio of heterozygote excess or deficit (Cornuet and Luikart 1996)

³IAM, TPM, SMM = infinite alleles, two-phase and stepwise mutational models of microsatellite evolution, respectively (see text)

Table 6. Probability of identity given the observed allele frequencies ($P_{(ID)}$) and probability of identity given the population is comprised of first-order relatives ($P_{(ID)sib}$) computed for each of 12 polymorphic microsatellite loci in brown bear populations on AFOG and KOD, Alaska. Locus specific values are given in scientific notation.

Locus	<u>AFOG</u>		<u>KOD</u>	
	$P_{(ID)}$	$P_{(ID)sib}$	$P_{(ID)}$	$P_{(ID)sib}$
G1A	4.23E-01	6.91E-01	1.89E-01	4.70E-01
G10B	7.41E-01	8.75E-01	9.08E-01	9.54E-01
G10C	3.66E-01	6.32E-01	3.71E-01	5.93E-01
G1D	4.46E-01	6.84E-01	4.03E-01	6.45E-01
G10J	3.94E-01	6.32E-01	3.77E-01	5.98E-01
G10L	7.49E-01	8.78E-01	9.26E-01	9.63E-01
G10P	3.73E-01	6.03E-01	3.84E-01	6.15E-01
G10X	7.49E-01	8.78E-01	8.84E-01	9.41E-01
Uar μ 26	8.62E-01	9.35E-01	4.06E-01	6.66E-01
Uar μ 50	2.90E-01	5.66E-01	8.90E-01	9.45E-01
Uar μ 59	4.92E-01	7.22E-01	3.75E-01	6.32E-01
CXX203	4.62E-01	6.98E-01	4.31E-01	6.65E-01
$P_{(ID)multilocus}$	0.000239	0.020422	0.000177	0.015098
P_{shadow}	1/4184	1/50	1/5649	1/66

Table 7. Distribution of MHC DQB1 exon 2 alleles among brown bears of AFOG, KOD and KAT

Haplotype	Position	Number of Haplotypes per Population		
		AFOG	KOD	KAT
	00000000001111112			
	55555668991226670			
	15678279588341280			
UarDQB1*001	GCTCCCTAATGCTCAA	27	31	-
UarDQB1*002C.G...C	-	1	-
UarDQB1*003AGTCAGGGTC	-	-	7
UarDQB1*004	.GGTG.CAGTCAGGGTC	-	-	7
UarDQB1*005	A....A.AG.CAG..TC	-	-	1
UarDQB1*006A..CAG..TC	-	-	2
UarDQB1*007	.GGTG.CAG.CAGGGTC	-	-	1
UarDQB1*008	A.....AG.CAG..TC	-	-	1
UarDQB1*009A..CAGGGTC	-	-	1
UarDQB1*010A.TCAGGG.C	-	-	1

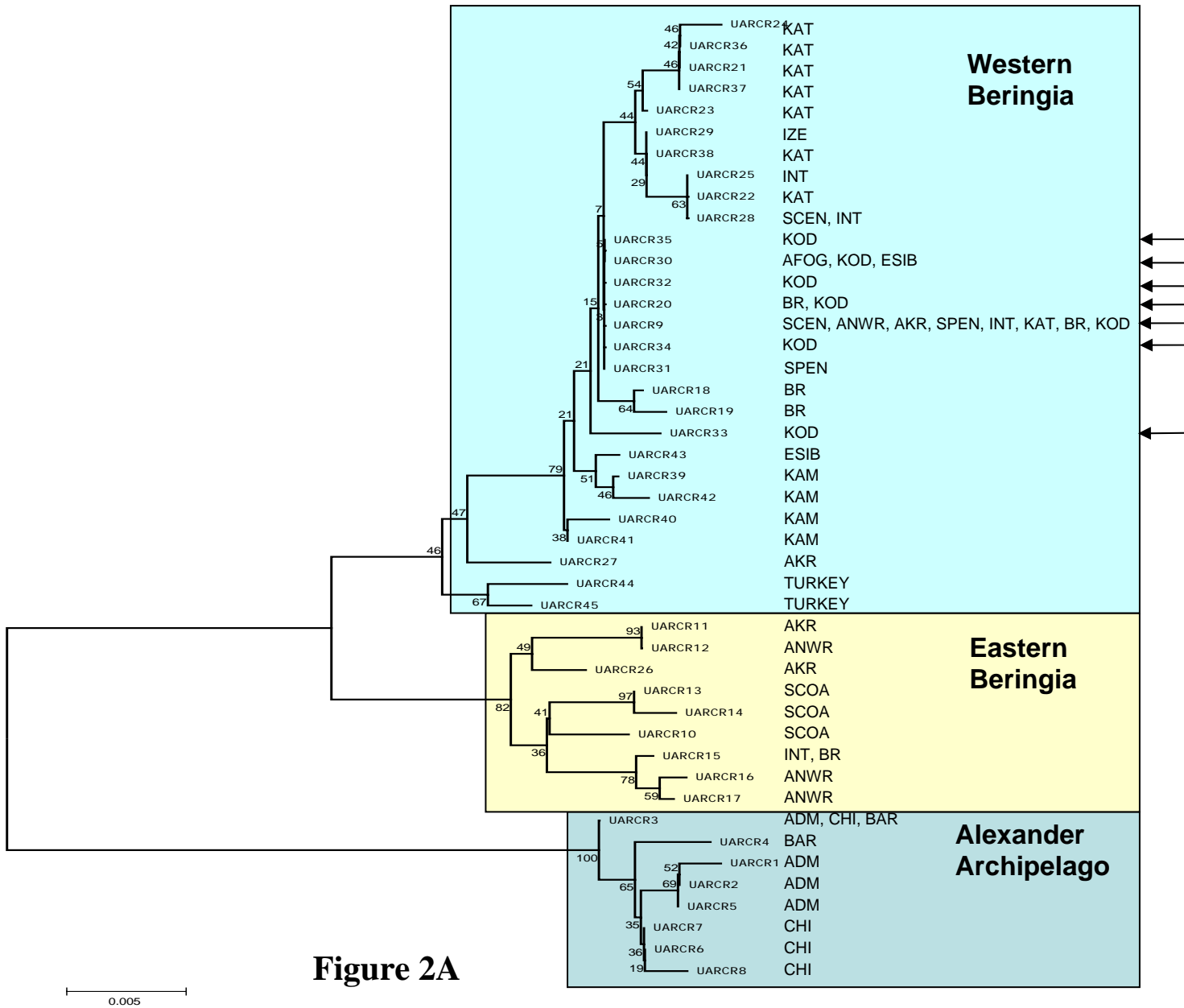

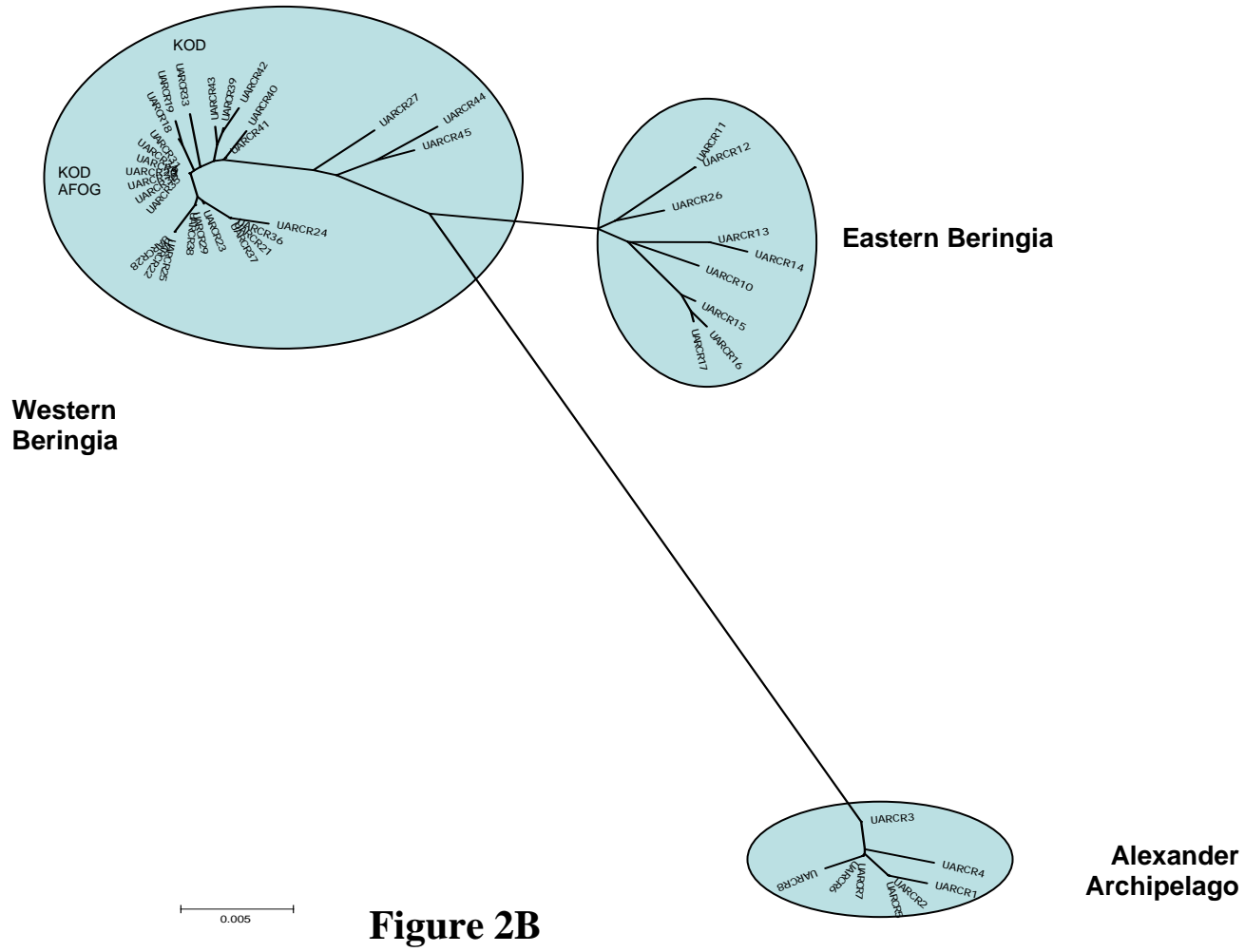

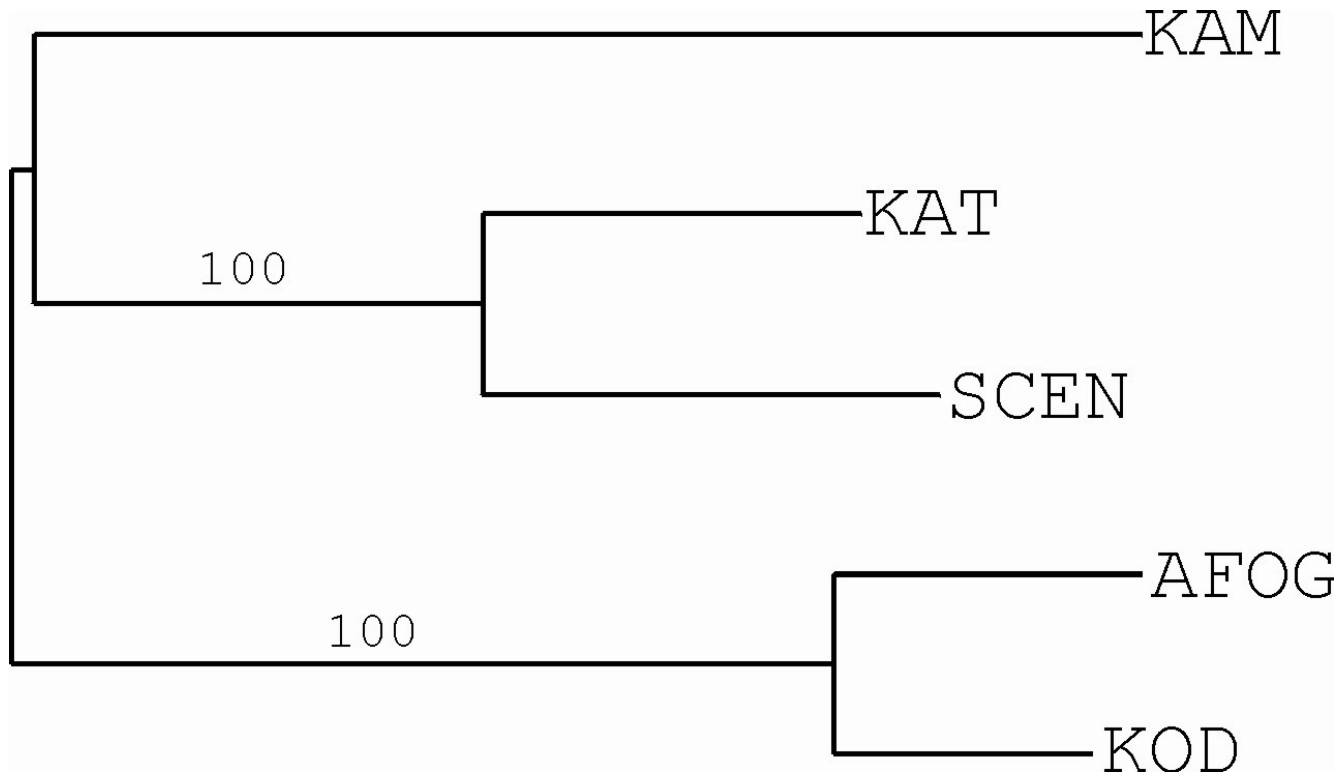

Figure 3

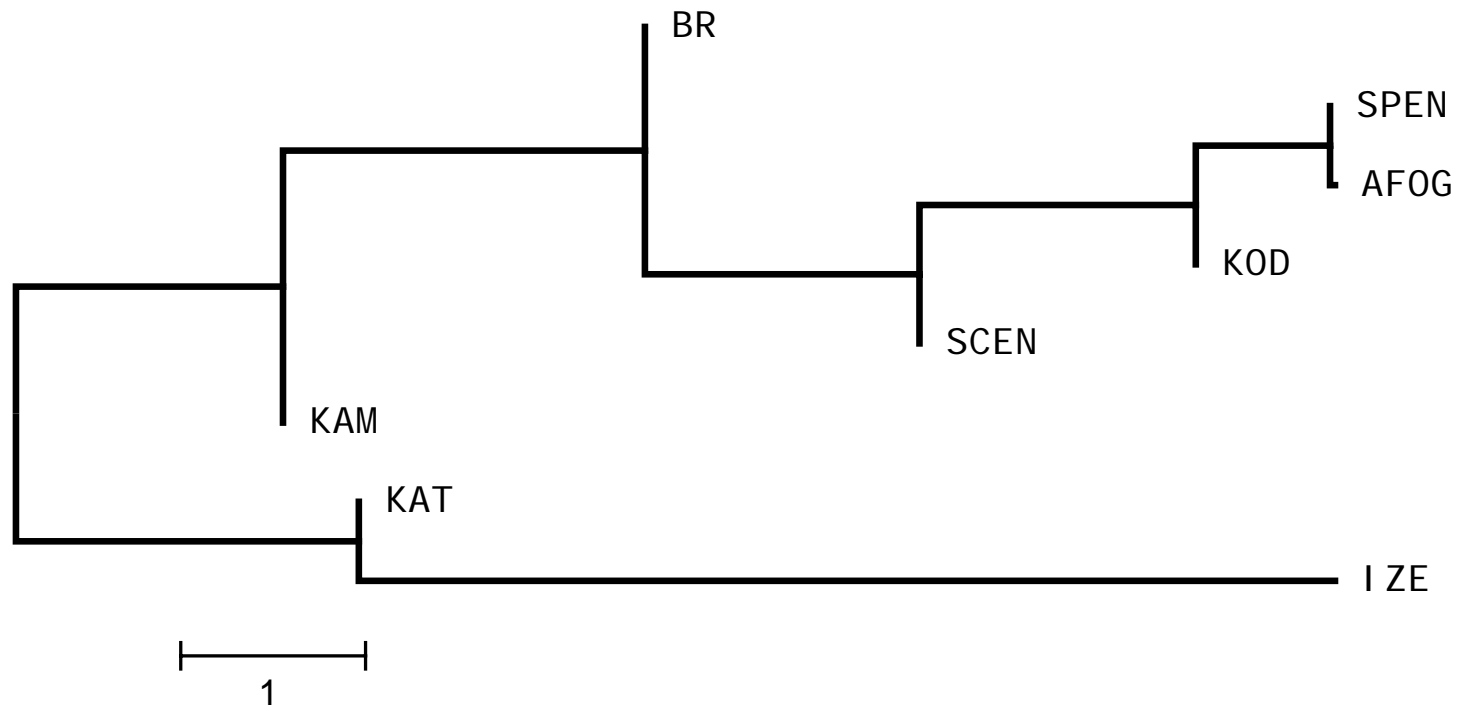

Figure 4

Figure 5. Continued.

	Nucleotide Position																									
	111	111	111	111	111	111	111	111	111	111	111	111	111	111	122	222	222	222	222	222	222	222	222	222	222	222
<u>Sequence ID</u>	555	666	666	666	677	777	777	778	888	888	888	999	999	999	900	000	000	001	111	111	111	222	222	222	789	
	789	012	345	678	901	234	567	890	123	456	789	012	345	678	901	234	567	890	123	456	789	012	345	678		
<i>UrarDQB1*001</i>	TAC	TTC	AAC	CAG	CAG	AAG	GAC	ATC	ATG	GAG	CAG	ACG	CGG	GCC	GAG	GTG	GAC	ACG	GTG	TGC	AGA	CAC	AAC	TAC		
<i>UrarDQB1*002</i>C.		
<i>UrarDQB1*003</i>GG	T..C.		
<i>UrarDQB1*004</i>GG	T..C.		
<i>UrarDQB1*005</i>	T..C.		
<i>UrarDQB1*006</i>	T..C.		
<i>UrarDQB1*007</i>GG	T..C.		
<i>UrarDQB1*008</i>	T..C.		
<i>UrarDQB1*009</i>GG	T..C.		
<i>UrarDQB1*010</i>GGC.		
#Zaca-DQB*11GG	..T	AGC	C..G.C.T		
#Calu-DQB1*01GG	...	GG.G	...	T..G.	.A.	C..		
#HLA-DRB1-1105GG	...	AGC	T..	C..	..A	G.C	.G.C.C	TAC		
#Urma-DRB*01	.C.	.GGC.G	C..	T..G.	G..C.C	TAC		
#HLA-DQB2	.GG	AA.	...	T.T	A..	G.C	TT.	T.G	GA.	C..	G..	CG.	GCC	..G	.T.	.AC	A.G	GT.	TGC	A.A	CAC	A..	T..	G.G		

Figure 6.

	* * *		* *	* *		*	*	*	** *	* *
	1	1111111112	2222222223	3333333334	4444444445	5555555556	6666666667	777777]		
	1234567890	1234567890	1234567890	1234567890	1234567890	1234567890	1234567890	123456]		
#UrarDQB1*001	VYQFKGECYF	TNGTERVRL	TRYIYNREEF	VHYDSDVGEY	RPVTELGRPD	AEYFNQKDI	MEQTRAEVDT	VCRHNY		
#UrarDQB1*002H	.A.....A...		
#UrarDQB1*003Y	.RF.....H	.A.....	...W....FA...		
#UrarDQB1*004GV	..H.....Y	.RF.....H	.A.....	...W....FA...		
#UrarDQB1*005	N.....Y	.R.....H	.A.....FA...		
#UrarDQB1*006YH	.A.....FA...		
#UrarDQB1*007GV	..H.....Y	.R.....H	.A.....	...W....FA...		
#UrarDQB1*008Y	.R.....H	.A.....FA...		
#UrarDQB1*009YH	.A.....	...W....FA...		
#UrarDQB1*010Y	..F.....H	.A.....	...W....A...		
#Zaca-DQB*11	.F.....SY	.RF.....W.S...	L.R...A..		
#Calu-DQB1*01	A.N.....	.RF.....	.A.....W	...W.G..E	L.RK...L..		
#HLA-DRB1-1105	LEYST...H	F.....F	D..F..Q..Y	.RF.....F	.A.....	E..W.S...F	L.DR..A...Y		
#URma-DRB*01	.RMY.A..HF	A.S.....	ARF.....	.A.....R	..SW.P..EL	L.RA..A...Y		
#HLA-DQB2	?V....M...GV	A.....G.Y	GRF.....F	QA.....SI	EDWN.YKDFL	EQERA.VDKV	CRHNYE		

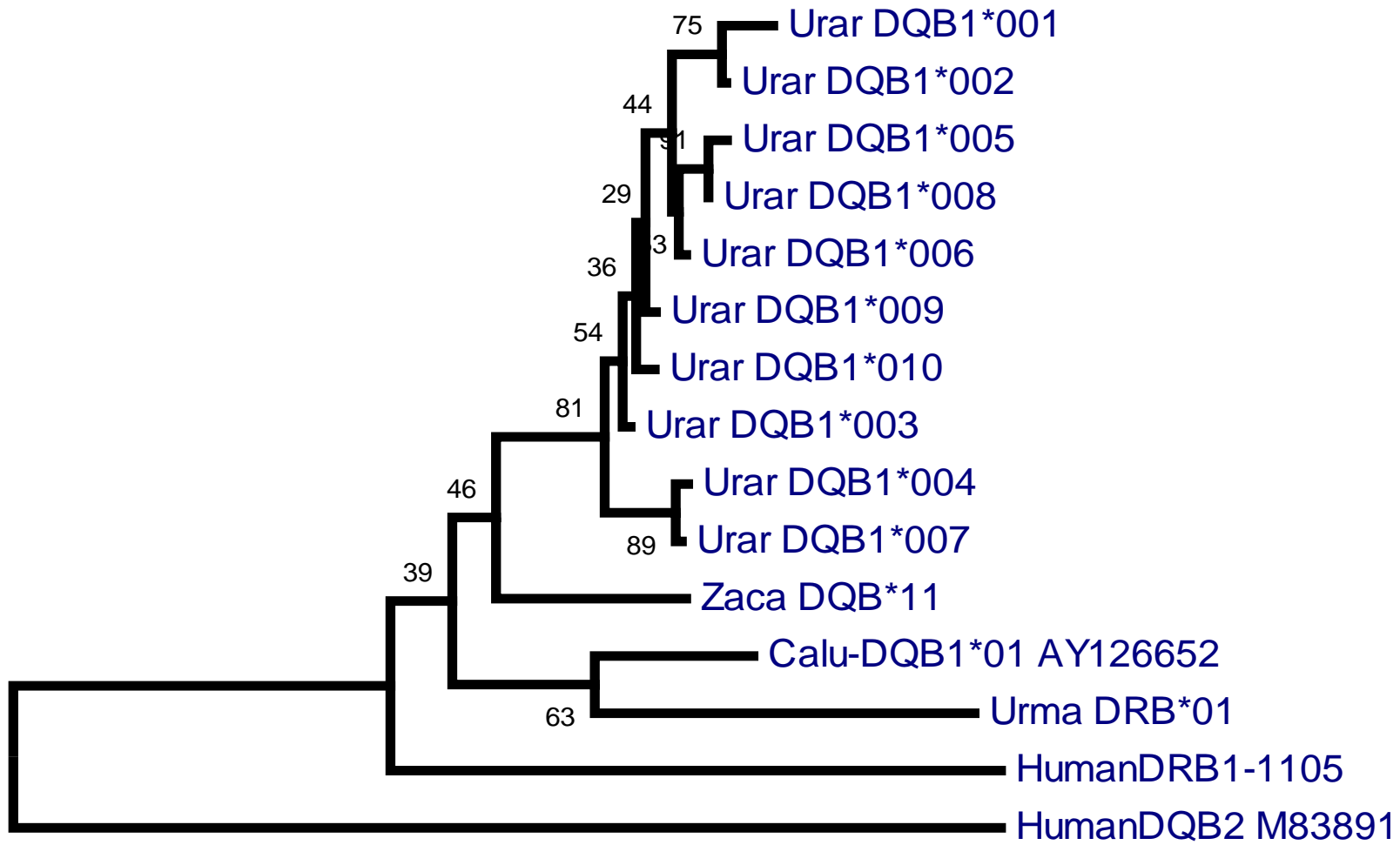

Figure 7

**APPENDIX 1
SAMPLE AND LOCALE DATA**

Specimen ID	Cert#	Type/ Status	Sex	Age	StudyArea	Location	Date Collected	UCU#	HAP Control Region	HAP DQB	# Microsats collected	Total skull measure	Comments
UAR (20)510657(1)	UAM Cat# 510657	Muscle/ EtOH	F	6	Kodiak	Terror Bay, east of Baumann Creek	23-Apr-93	302		DQB1	14		
UAR (21)510648(2)	UAM Cat# 510648	Muscle/ EtOH					17-Nov-93						
UAR (22)510476(3)	UAM Cat# 510476	Muscle/ EtOH	M	4	Kodiak	Sharatin Bay	13-May-93	330	CR30		14		
UAR (23)510479(4)	UAM Cat# 510479	Muscle/ EtOH	F	4	Kodiak	Kizhuyak Bay, Dovolino Point	15-May-93	330	CR9	DQB1	14		
UAR (24)510579(5)	UAM Cat# 510579	Muscle/ EtOH	M	5	Kodiak	S. Arm Uganik Bay, east side	02-May-93	304	CR9	DQB1	14		
UAR (25)510472(6)	UAM Cat# 510472	Muscle/ EtOH	M	15	Kodiak	Red Lake	12-May-93	312			14		
UAR (26)510454(7)	UAM Cat# 510454	Muscle/ EtOH	F	13	Kodiak	Uganik Lake, upper end	08-May-93	305	CR30		14		
UAR (27)510578(8)	UAM Cat# 510578	Muscle/ EtOH	F	3	Kodiak	Kiliuda Bay, 3 mi W of Pivot Point	01-May-93	319	CR34		14		
UAR (28)510573(9)	UAM Cat# 510573	Muscle/ EtOH	M	4	Kodiak	Karluk River, head of Karluk Lagoon	03-May-93	309	CR20		14		
UAR (29)510569(10)	UAM Cat# 510X69	Muscle/ EtOH					17-Nov-93						Hunter (originally listed w/ cert# 510X69)
UAR (30)(11)	?1	Muscle/ EtOH					17-Nov-93						Hunter
UAR (31)(12)	?2	Muscle/ EtOH					17-Nov-93						Hunter
UAR (32)(13)	?3	Muscle/ EtOH					17-Nov-93						Hunter
UAR (33)51045(14)	UAM Cat# 51045						17-Nov-93						

UAR (34)510652(15)	UAM Cat# 510652	Muscle/ EtOH	F	6	Kodiak	Spiridon Bay, 5 mi W of Weasel Cv	17-Apr-93	306	CR9		14		
UAR (35)510455(16)	UAM Cat# 510455	Muscle/ EtOH	M	5	Kodiak	Uganik Lake, head of lake	04-May-93	305	CR30		14		
UAR (36)510410(17)	UAM Cat# 510410	Muscle/ EtOH	M	9	Kodiak	Karluk Lake, Alder Creek	09-May-93	310	CR32		14		
UAR (37)510637(18)	UAM Cat# 510687	Muscle/ EtOH	M	7	Kodiak	Frazer Lake, east side	30-Apr-93	313	CR9		14		
UAR (38)510667(19)	UAM Cat# 510667	Muscle/ EtOH	M	9	Kodiak	Terror Bay, W side opposite Falls	22-Apr-93	302	CR30	DQB1	14		
UAR (39)510679(20)	UAM Cat# 510679	Muscle/ EtOH	F	6	Kodiak	Karluk Lake, Falls Creek	26-Apr-93	310	CR20	DQB1	14		
UAR (40)510656(21)	UAM Cat# 510656	Muscle/ EtOH	M	16	Kodiak	Zachar Bay, 3 mi up Zachar River	18-Apr-93	307	CR9	DQB1	14		
UAR (41)(22)	UAM Cat# 510XXX	Muscle/ EtOH					17-Nov-93						Hunter
UAR (42)522099(23)	?	Muscle/ EtOH					17-Nov-93						Hunter (MEL records have cert# 522099)
UAR (43)510664(24)	UAM Cat# 510664	Muscle/ EtOH	F	14	Kodiak	Deadman Bay, Hepburn Peninsula	24-Apr-93	315	CR9	DQB1	14		
UAR (44)510577(25)	UAM Cat# 510577	Muscle/ EtOH	M	11	Kodiak	Uyak Bay, 3 mi SW of Alf Island	03-May-93	308	CR30	DQB1	14		
UAR (45)510406(26)	UAM Cat# 510406	Muscle/ EtOH	F	26	Kodiak	Ayakulik River, Bare Creek	25-Apr-93	312	CR9		14		
UAR (46)510567(27)	UAM Cat# 510567	Muscle/ EtOH					17-Nov-93						Hunter (originally listed w/ cert# 510X67)
UAR (47)510692(28)	UAM Cat# 510692	Muscle/ EtOH	F	3	Kodiak	Ouzinkie Narrows, Neva Cove	05-May-93	329	CR30		14		
UAR (48)510693(29)	UAM Cat# 510693	Muscle/ EtOH	M	11	Kodiak	Portage Bay	02-May-93	316			14		
UAR (49)510698(30)	UAM Cat# 510698	Muscle/ EtOH	M	9	Kodiak	Kiliuda Bay, Shearwater	07-May-93	320	CR9		14		

						Peninsula							
UAR (50)510400(31)	UAM Cat# 510400	Muscle/ EtOH					17-Nov-93						
UAR (51)510673(32)	UAM Cat# 510673	Muscle/ EtOH	M	5	Kodiak	Uyak Bay, 2.5 mi N of head of bay	27-Apr-93	308	CR33		14		
UAR (52)510671(33)	UAM Cat# 510671	Muscle/ EtOH	F	5	Afognak	Afognak Is, Muskomee Bay	28-Apr-93	206	CR30	DQB1	14		
UAR (53)510169(34)	UAM Cat# 510169	Muscle/ EtOH					17-Nov-93						
UAR (54)510655(35)	UAM Cat# 510655	Muscle/ EtOH	F	12	Kodiak	Zachar Bay, N side near cannery	20-Apr-93	307			14		
UAR (55)(36)	XX6454	Muscle/ EtOH					17-Nov-93						Hunter
UAR (56)510677(37)	UAM Cat# 510677	Muscle/ EtOH	F	4	Kodiak	Spiridon Bay, head of bay	01-May-93	306	CR30		14		
UAR (57)(38)	XX5004	Muscle/ EtOH					17-Nov-93						Hunter
UAR (58)510561(39)	UAM Cat# 510581	Muscle/ EtOH	F	4	Kodiak	Karluk Lake, b/t Camp Is & Omalley	07-May-93	310	CR9		14		
UAR (59)510467(40)	UAM Cat# 510467	Muscle/ EtOH	M	9	Afognak	Shuyak Isalnd, Big Fort Island	10-May-93	201	CR30	DQB1	14		
UAR (60)510408(41)	UAM Cat# 510408	Muscle/ EtOH	M	14	Kodiak	Kiluda Bay, SW Arm	07-May-93	319	CR20		14		
UAR (61)510404(42)	UAM Cat# 510404	Muscle/ EtOH	M	11	Kodiak	Terror Bay, near Falls Creek	12-Apr-93	302	CR30		14		
UAR (62)54X453(43)	54X453	Muscle/ EtOH					17-Nov-93						Hunter
UAR (63)54751(44)	54751	Muscle/ EtOH					17-Nov-93						
UAR (64)510672(45)	UAM Cat# 510672	Muscle/ EtOH	M	4	Kodiak	Deadman Bay, head of bay	28-Apr-93	315			14		
UAR (65)510411(46)	UAM Cat# 510411	Muscle/ EtOH	M	11	Kodiak	Karluk Lake, Falls Creek	08-May-93	310	CR20		14		
UAR (66)417193(47)	417193	Muscle/ EtOH					17-Nov-93						Hunter
UAR (67)(48)	XXX890	Muscle/ EtOH					17-Nov-93						Hunter

UAR (68)50572(49)	UAM Cat# 50572	Muscle/ EtOH					17-Nov-93						
UAR (69)51667(50)	51667	Muscle/ EtOH					17-Nov-93						
UAR 07902	A-07902	Muscle/ TPB	F	~5	Kodiak	Dog Salmon River	05-May-03	313	CR20		14		
UAR 07912	A-07912	Muscle/ TPB	M	~12	Kodiak	Deadman Bay, Alpine Cove	03-May-03	315	CR33				
UAR 07913	A-07913	Muscle/ TPB	M	AD	Kodiak	Deadman Bay, Alpine Cove	03-May-03	315	CR30		14		
UAR 07934	A-07934	Muscle/ TPB	M	AD	Kodiak	Uyak Bay, Old Uyak	05-Mar-03	309	CR20		14		
UAR 07938	A-07938	Muscle/ TPB	M	~6	Afognak	Afognak Is, Malina Creek	12-May-03	206	CR30	DQB1	14		
UAR 07939	A-07939	Muscle/ TPB	F	~2	Kodiak	Karluk River, Portage	15-May-03	309			14		
UAR 07982(1)		Tissue/ TPB	M		Kodiak						14		
UAR 07983(2)		Tissue/ TPB	M		Kodiak						14		
UAR 07984(3)		Tissue/ TPB	M		Kodiak					DQB1	14		
UAR 07985(4)		Tissue/ TPB	M		Kodiak						14		
UAR 07986(5)		Tissue/ TPB	F		Kodiak					DQB1	14		
UAR 07988(6)		Tissue/ TPB	M		Kodiak					DQB1	14		
UAR 07995(7)		Tissue/ TPB	M		Kodiak						14		
UAR 07996(8)		Tissue/ TPB	F		Kodiak					DQB1	14		
UAR 07997(9)		Tissue/ TPB	M		Kodiak						14		
UAR 08969	A-08969	Muscle/ TPB	F	AD	Kodiak	Kiliuda Bay, North Arm	29-Oct-03	319	CR9		14		
UAR 08971	A-08971	Muscle/ TPB	F	~3	Kodiak	Kiliuda Bay, Pivot Point	28-Oct-03	320	CR34		14		
UAR 08972	A-08972	Muscle/ TPB	F	~3	Kodiak	Ugak Bay, Little Eagle Harbor	27-Oct-03	321	CR30		14		

UAR 08994	A-08994	Muscle/ TPB	F	~8	Kodiak	Anton Larsen Bay, Red Cloud Cr	07-Nov-03	329	CR30		14		
UAR 08995(304952)	A-08995	Muscle/ TPB	M	AD	Kodiak	Lake Catherine, Womens Bay	09-Nov-03	329	CR30		14		SKL304952
UAR 17013(10)	A17013	Tissue/ TPB	M	3	Kodiak	Uyak Bay	04-Nov-04				14		
UAR 17014(11)	A17014	Tissue/ TPB	M	5	Kodiak	Spiridon Head	30-Oct-04			DQB1	14		
UAR 17017(12)	A17017	Tissue/ TPB	F	5	Afognak	N. Malina Bay	01-Nov-04		CR30	DQB1	14		
UAR 17020(13)	A17020	Tissue/ TPB	M	7	Kodiak	Kalugnak Bay	05-Nov-04			DQB1	14		
UAR 17021(14)	A17021	Tissue/ TPB	M		Kodiak	Sturgeon River	01-Nov-04			DQB1	14		
UAR 17022(15)	A17022	Tissue/ TPB	M	20	Afognak	Shuyak Is	25-Oct-04		CR30	DQB1	14		
UAR 17023(16)	A17023	Tissue/ TPB	M	12	Kodiak	Head of Larsen Bay	07-Nov-04				14		
UAR 17024(17)	A17024	Tissue/ TPB	F		Afognak	Malina Bay	07-Nov-04		CR30	DQB1	14		
UAR 17025(18)	A17025	Tissue/ TPB	F		Kodiak	Old Harbor Village	09-Nov-04						
UAR 17026(19)	A17026	Tissue/ TPB	M		Kodiak	Horse Marine	08-Nov-04				14		
UAR 17027(20)	A17027	Tissue/ TPB	F	4	Kodiak	Halibut Bay	02-Nov-04			DQB1	14		
UAR 17028(21)	A17028	Tissue/ TPB	M	14	Kodiak	Zachar River	07-Nov-04				14		
UAR 17029(22)	A17029	Tissue/ TPB	M	5	Kodiak	Kalugnak Bay	09-Nov-04				14		
UAR 17031(23)	A17031	Tissue/ TPB	M	4	Kodiak	Saltery River	08-Nov-04			DQB1	14		
UAR 17032(24)	A17032	Tissue/ TPB	M	6	Kodiak	Red River	10-Nov-04				14		
UAR 17033(25)	A17033	Tissue/ TPB	F	12	Kodiak	N of Alpine Cove	07-Nov-04				14		
UAR 17034(26)	A17034	Tissue/ TPB	F		Kodiak	Portage Karluk River	10-Nov-04				14		
UAR 17036(27)	A17036	Tissue/ TPB	F		Kodiak	Uganik Cannery	20-Oct-04				14		

UAR 17037(28)	A17037	Tissue/ TPB	F		Kodiak	Kiliuda Bay North	12-Nov-04				14		
UAR 17038(30)	A17038	Tissue/ TPB	M		Kodiak	Buskin Valley	17-Nov-04				14		
UAR 17039(29)	A17039	Tissue/ TPB	M	16	Kodiak	Sturgeon Bay	17-Nov-04				14		
UAR 17040(31)	A17040	Tissue/ TPB	F		Kodiak	Sitkalidak Is	19-Nov-04				14		
UAR 17044(32)	A17044	Tissue/ TPB	M		Kodiak	Akalura Lk	19-Nov-04				14		
UAR 17045(33)	A17045	Tissue/ TPB	M		Kodiak	Sitkalidak Is	25-Nov-04				14		
UAR 17046(34)	A17046	Tissue/ TPB	M	14	Kodiak	Uganik Is	25-Nov-04				14		
UAR 17047(35)	A17047	Tissue/ TPB	M	13	Kodiak	Terror Bay	27-Nov-04				14		
UAR 20268	A-20268	Muscle/ TPB	M	~6	Kodiak	Summit Lake	16-Nov-03	326	CR20		14		
UAR 20273	A-20273	Muscle/ TPB	U		Kodiak	Port Bailey	01-Nov-03	301	CR30		13		
UAR 20274	A-20274	Muscle/ TPB	F	AD	Kodiak	Port Bailey	01-Nov-03	301	CR30		14		
UAR 20276	20276	Tissue&Hair/ TPB&Dry	M		Kodiak	OLGA BAY	06-Apr-04			DQB1	14	27.5	
UAR 20277	20277	Tissue&Hair/ TPB&Dry	M		Afognak	BIG TONKI	07-Apr-04		CR30	DQB1	14	25	
UAR 20278	20278	Tissue&Hair/ TPB&Dry	M		Afognak	PERENOSA BAY	12-Apr-04		CR30	DQB1	14	26.81	
UAR 20280	20280	Tissue&Hair/ TPB&Dry	M		Kodiak	HEITMAN MTN	16-Apr-04			DQB2	14	22.26	
UAR 20281	20281	Tissue&Hair/ TPB&Dry	M		Kodiak	KAGUYAK BAY	18-Apr-04			DQB1	14	28.38	
UAR 20283	20283	Tissue&Hair/ TPB&Dry	M		Kodiak	STURGEON RIVER	18-Apr-04				14	25.88	
UAR 20284	20284	Tissue&Hair/ TPB&Dry	M		Kodiak	GRANTS LAGOON	21-Apr-04			DQB1	14	25.44	
UAR 20287	20287	Tissue&Hair/ TPB&Dry	M		Afognak	DUCK BAY	22-Apr-04		CR30	DQB1	14	25.62	

UAR 20288	20288	Tissue&Hair/ TPB&Dry	M		Afognak	NE SHUYAK ISLAND	16-Apr-04		CR30	DQB1	14	24.94	
UAR 20289	20289	Tissue&Hair/ TPB&Dry	M		Kodiak	RED RIVER	24-Apr-04				14	28.07	
UAR 20291	20291	Tissue&Hair/ TPB&Dry	M		Kodiak	EAST ARM UGANIK	23-Apr-04				14	26.63	
UAR 20293	20293	Tissue&Hair/ TPB&Dry	F		Kodiak	KARLUK LAKE	26-Apr-04			DQB1	14	24.37	
UAR 20294	20294	Tissue&Hair/ TPB&Dry	M		Kodiak	NE SHARATIN MTN	25-Apr-04				14	27.38	
UAR 20295	20295	Tissue&Hair/ TPB&Dry	M		Kodiak	SOUTH ARM UGANIK	25-Apr-04					20	
UAR 20298	20298	Tissue&Hair/ TPB&Dry	M		Kodiak	FRAZER LAKE	26-Apr-04				14	29.07	
UAR 20299	20299	Tissue&Hair/ TPB&Dry	M		Kodiak	FRAZER LAKE	25-Apr-04				14	25.88	
UAR 20300	20300	Tissue&Hair/ TPB&Dry	M		Afognak	RASPBERRY ISLAND	26-Apr-04		CR30	DQB1	14	25.31	
UAR 20313	A-20313	Brain&Hair/ TPB	M	AD	Kodiak	Sitkalidak Is, Rolling Bay	11-Apr-03	317	CR30		14		
UAR 20314	A-20314	Muscle/ TPB	M	~4	Kodiak	Viekoda Bay	17-Apr-03	301	CR30		14		
UAR 20315	A-20315	Brain&Muscle/ TPB	F	AD	Kodiak	NE Arm Uganik Bay	17-Apr-03	304	CR30		14		
UAR 20316	A-20316	Brain&Muscle/ TPB	F	~3	Kodiak	Monashka Bay, Neva Creek	20-Apr-03	329			14		
UAR 20317	A-20317	Muscle/ TPB	F	~6	Kodiak	Halibut Bay	21-Apr-03	311			14		
UAR 20318	A-20318	Muscle/ TPB	M	~12	Kodiak	Grants Lagoon	19-Apr-03	311	CR20		14		
UAR 20320	A-20320	Muscle/ TPB	M	~7	Kodiak	Pasagshak Bay, Rose Tead	23-Apr-03	326	CR9		14		
UAR 20322	A-20322	Muscle/ TPB	M	~10	Kodiak	Red Lake, Southeast Creek	24-Apr-03	312	CR9		14		
UAR 20325	A-20325	Muscle/ TPB	M	~12	Kodiak	Karluk Lake, Canyon Creek	23-Apr-03	310	CR20		14		

UAR 20327	A-20327	Muscle/ TPB	M	~12	Afognak	Afognak Is, Paramanof Bay	26-Apr-03	204	CR30	DQB1	14		
UAR 20329	A-20329	Muscle/ TPB	M	AD	Kodiak	Frazer Lake, NE end	26-Apr-03	313			14		
UAR 20331	A-20331	Skin/ TPB	M	~17	Kodiak	Terror Bay, head of bay	11-May-03	302			14		
UAR 20332	A-20332	Muscle/ TPB	M	AD	Kodiak	Red Lake, Southeast Creek	27-Apr-03	312	CR9		14		
UAR 20334	A-20334	Muscle/ TPB	M	~4	Kodiak	Red Lake	28-Apr-03	312	CR9		14		
UAR 20337	A-20337	Muscle/ TPB	M	AD	Kodiak	Larsen Bay, head of bay	24-Apr-03	309	CR9		14		
UAR 20342	A-20342	Muscle/ TPB	F	~2	Kodiak	Spiridon Lake	30-Apr-03	306	CR30				
UAR 20347	A-20347	Muscle/ TPB	M	~3	Kodiak	Karluk Lake, Canyon Creek	02-May-03	310	CR32		14		
UAR 20398(304619)	A-20398	Muscle/ TPB	F	AD	Kodiak	Red Lake	06-May-03	312			14		SKL304619
UAR 20399	A-20399	Skin/ TPB	M	~17	Kodiak	Dog Salmon River	07-May-03	313					
UAR 20701	20701	Tissue&Hair/ TPB&Dry	F		Afognak	RASPBERRY ISLAND	27-Apr-04		CR30	DQB1	14	21.06	
UAR 20702	20702	Tissue&Hair/ TPB&Dry	M		Kodiak	DOG SALMON RIVER	23-Apr-04				14	25.56	
UAR 20703	20703	Tissue&Hair/ TPB&Dry	M		Kodiak	DOG SALMON RIVER	27-Apr-04				14	22.62	
UAR 20705	20705	Tissue&Hair/ TPB&Dry	M		Kodiak	UGANIK RIVER	22-Apr-04				14	27.75	
UAR 20706	20706	Tissue&Hair/ TPB&Dry	M		Kodiak	UGANIK BAY SOUTH	27-Apr-04				14	25.38	
UAR 20707	20707	Tissue&Hair/ TPB&Dry	M		Kodiak	ZACHAR RIVER	26-Apr-04				14	21	
UAR 20708	20708	Tissue&Hair/ TPB&Dry	F		Kodiak	SITKALIDAK ISLAND	28-Apr-04				14	21.88	
UAR 20709	20709	Tissue&Hair/ TPB&Dry	F		Kodiak	SOUTH OLGA LAKES	29-Apr-04				14	19.06	

UAR 20710	20710	Tissue&Hair/ TPB&Dry	M		Kodiak	SOUTH OLGA LAKES	24-Apr-04				14	24.37	
UAR 20712	20712	Tissue&Hair/ TPB&Dry	M		Kodiak	SHAG BLUFF	27-Apr-04				14	28.56	
UAR 20713	20713	Tissue&Hair/ TPB&Dry	M		Kodiak	KIAVAK BAY	29-Apr-04				14	25.12	
UAR 20714	20714	Tissue&Hair/ TPB&Dry	F		Kodiak	KARLUK LAKE	30-Apr-04				14	24.88	
UAR 20715	20715	Tissue&Hair/ TPB&Dry	F		Kodiak	KILIUDA BAY	27-Apr-04				14	22.44	
UAR 20716	20716	Tissue&Hair/ TPB&Dry	M		Afognak	MCDONALD LAGOON	01-May-04		CR30	DQB1	14	21.01	
UAR 20717	20717	Tissue&Hair/ TPB&Dry	M		Kodiak	VIEKODA BAY	02-May-04				14		
UAR 20718	20718	Tissue&Hair/ TPB&Dry	M		Kodiak	SHARATIN BAY	03-May-04				14	25.38	
UAR 20719	20719	Tissue&Hair/ TPB&Dry	F		Kodiak	PACKERS SPIT	03-May-04				14	21.94	
UAR 20721	20721	Tissue&Hair/ TPB&Dry	F		Kodiak	LAKE MIAM	01-May-04				14	21.32	
UAR 20723	20723	Tissue&Hair/ TPB&Dry	M		Kodiak	KARLUK LAKE	02-May-04				14	24.63	
UAR 20724	20724	Tissue&Hair/ TPB&Dry	M		Kodiak	KARLUK LAKE	02-May-04				14	26.19	
UAR 20731	20731	Tissue&Hair/ TPB&Dry	M		Kodiak	KALSIN RIDGE	04-May-04				14	22.75	
UAR 20732	20732	Tissue&Hair/ TPB&Dry	F		Kodiak	KALSIN RIDGE	04-May-04				14	22.81	
UAR 20733	20733	Tissue&Hair/ TPB&Dry	M		Kodiak	GREYBACK MTN	04-May-04				14	24.94	
UAR 20734	20734	Tissue&Hair/ TPB&Dry	M		Kodiak	KILIUDA BAY	05-May-04				14	24.88	
UAR 20735	20735	Tissue&Hair/ TPB&Dry	M		Kodiak	BOULDER BAY	05-May-04				14	27.82	
UAR 20736	20736	Tissue&Hair/ TPB&Dry	M		Kodiak	BEAR VALLEY	05-May-04				14	18.19	

UAR 20737	20737	Tissue&Hair/ TPB&Dry	F		Kodiak	UGANIK BAY	05-May-04				14	19.31	
UAR 20741	20741	Tissue&Hair/ TPB&Dry	F		Kodiak	SULUA BAY	04-May-04				14	21.5	
UAR 20743	20743	Tissue&Hair/ TPB&Dry	M		Kodiak	ANVIL LAKE	04-May-04				14	25.94	
UAR 20744	20744	Tissue&Hair/ TPB&Dry	M		Kodiak	KARLUK LAKE	04-May-04				14	26.57	
UAR 20745	20745	Tissue&Hair/ TPB&Dry	F		Kodiak	RED LAKE	04-May-04					22.19	
UAR 20746	20746	Tissue&Hair/ TPB&Dry	M		Kodiak	UGAK BAY	03-May-04				14	28	
UAR 20769(304912)	A-20769	Muscle/ TPB	F	AD	Kodiak	Uganik Island, north end	11-Nov-03	312	CR30		14		SKL304912
UAR 22653	UAM Cat# 49381	Muscle/ EtOH	M		Kodiak	Kizhuyak Bay	26-Oct-98		CR30	DQB1	14		
UAR 22654	UAM Cat# 49382	Muscle/ EtOH	F		Kodiak	Buskin River	30-Oct-98		CR35		14		Cert# 522099.
UAR 22655	UAM Cat# 49383	Muscle/ EtOH	M		Kodiak	Frazer Lake; Middle Creek	27-Oct-98		CR20	DQB1	14		Cert# 522096.
UAR 22656	UAM Cat# 49384	Muscle/ EtOH	F		Afognak	Mary Anderson Bay	28-Oct-98				14		Cert# 522052. (double check against UAR 22674)
UAR 22657	UAM Cat# 49385	Muscle/ EtOH	F		Kodiak	Cascade Creek, Karluk Lake	26-Oct-98		CR20		14		
UAR 22658(41)	UAM Cat# 49386	Muscle/ EtOH	F		Kodiak	Horse Marine Lake	30-Oct-98		CR20	DQB1 DQB1	14		Cert# 522151.
UAR 22659	UAM Cat# 49387	Muscle/ EtOH	M		Kodiak	Sulua Bay	26-Oct-98				14		
UAR 22660	UAM Cat# 49388	Muscle/ EtOH	M		Kodiak	Lake Genevieve, Kodiak Town	01-Nov-98		CR30	DQB1	14		
UAR 22663	UAM Cat# 49389	Muscle/ EtOH	F		Kodiak	Red Lake	27-Oct-98				14		Cert# 522097.

UAR 22664	UAM Cat# 49390	Muscle/ EtOH	M		Afognak	Discoverer Bay	30-Nov-98		CR30	DQB1	14	Duplicate AF: was AF22662. Relabeled 08Apr99.
UAR 22665	UAM Cat# 49391	Muscle/ EtOH	M		Kodiak	Deadman Bay	05-Nov-98		CR9			
UAR 22666	UAM Cat# 49392	Brain&Muscle/ EtOH	F		Kodiak	Biekoda Bay/Rolling Point			CR30		14	
UAR 22667	UAM Cat# 49393	Brain&Muscle/ EtOH	M		Kodiak	Buskin River	07-Nov-99		CR30		14	
UAR 22668	UAM Cat# 49394	Muscle/ EtOH	F		Kodiak	South Frazer Lake	08-Nov-98		CR9		14	Duplicate AF: was AF22653. Relabeled 08Apr99. Salted skull meat.
UAR 22669	UAM Cat# 49395	Muscle/ EtOH	Unk		Kodiak	Karluk Lagoon	01-Nov-98		CR20		14	Cert# 522153.
UAR 22670	UAM Cat# 49396	Brain&Muscle/ EtOH	Unk		Kodiak	Kaguyak Bay	10-Nov-99		CR9		14	
UAR 22671	UAM Cat# 49397	Muscle/ EtOH	M		Kodiak	American River	16-Nov-98		CR30		14	Duplicate AF: was AF 22655. Relabeled 08Apr99.
UAR 22672	UAM Cat# 49398	Muscle/ EtOH	M		Kodiak	Sturgeon Lagoon	05-Nov-98		CR32		14	Duplicate AF: was AF22654. Relabeled 08Apr99. Cert# 522072
UAR 22673	UAM Cat# 49399	Muscle/ EtOH	M		Afognak	Kazakof Bay	15-Nov-98		CR30	DQB1	14	Cert# 522053.

UAR 22674	UAM Cat# 49400	Muscle/ EtOH	M		Kodiak	Kalsin Bay	21-Nov-98		CR30		14		Duplicate AF: was AF22656. Relabeled 08Apr99 (check against UAR 22656)
UAR 22675	UAM Cat# 49401	Muscle/ EtOH	Unk		Kodiak	Narrow Cape	25-Nov-98		CR30		13		Duplicate AF: was AF22657. Relabeled 08Apr99.
UAR 22676	UAM Cat# 49402	Muscle/ EtOH	F		Kodiak	Buskin River	29-Nov-98		CR35		14		Duplicate AF: was AF22658. Relabeled 08Apr99.
UAR 22677	UAM Cat# 49403	Muscle/ EtOH	M		Kodiak	Buskin Lake	03-Nov-98		CR30		14		
UAR 22678	UAM Cat# 49404	Muscle/ EtOH	M		Kodiak	Amook Pass, Uyak Bay	01-Nov-98				14		Cert# 522152.
UAR 27586	UAM Cat# 49410	Brain&Muscle/ EtOH	M		Kodiak	Specific locality unknown.	23-Nov-98		CR30				
UAR 27587	UAM Cat# 49405	Brain&Muscle/ EtOH	F		Kodiak	Specific locality unknown.	23-Nov-98		CR30		14		
UAR 27588	UAM Cat# 49406	Brain&Muscle/ EtOH	M		Kodiak	Specific locality unknown.	23-Nov-98		CR30		14		
UAR 27589	UAM Cat# 49407	Brain&Muscle/ EtOH	M		Kodiak	Specific locality unknown.	23-Nov-98		CR30		14		
UAR 27590	UAM Cat# 49408	Muscle/ EtOH	Unk		Kodiak	Old Harbor	25-Jul-98		CR30		14		
UAR 27591	UAM Cat# 49409	Muscle/ EtOH	F		Kodiak	Larsen Bay	23-Oct-98		CR20		14		
UAR 27600	UAM Cat# 50498	Brain&Muscle/ EtOH	F		Kodiak	No specific locality recorded.	22-Apr-99		CR9		14		

UAR 27601	UAM Cat# 50499	Muscle/ EtOH	M		Kodiak	S Red Lake	21-Apr-99		CR20		13		Duplicate AF: was AF22668. Relabeled 08Apr99.
UAR 27602	UAM Cat# 50500	Muscle/ EtOH	M		Afognak	head of Danger Bay	23-Apr-99		CR30		14		
UAR 27603	UAM Cat# 50501	Brain&Muscle/ EtOH	M		Kodiak	Red Lake	23-Apr-99		CR32		14		
UAR 27604	UAM Cat# 50502	Brain&Muscle/ EtOH	M		Kodiak	S Uyak Bay	24-Apr-99		CR9		14		
UAR 27605	UAM Cat# 50503	Brain&Muscle/ EtOH	M		Kodiak	Uganik R	24-Apr-99		CR9		14		
UAR 27606	UAM Cat# 50504	Brain&Muscle/ EtOH	M		Kodiak	Kaguyak Bay	24-Apr-99				14		
UAR 27607	UAM Cat# 50505	Brain&Muscle/ EtOH	M		Kodiak	Olga Bay, W of Anchor Bay	26-Apr-99		CR20		14		
UAR 27608	UAM Cat# 50506	Brain&Muscle/ EtOH	M		Kodiak	S of Kodiak, Portage Bay	29-Apr-99		CR30		14		
UAR 27609	UAM Cat# 50507	Brain&Muscle/ EtOH	M		Kodiak	Karluk Lake; Salmon Creek	28-Apr-99		CR9		14		
UAR 27610	UAM Cat# 50508	Brain&Muscle/ EtOH	M		Kodiak	Uyak Bay; head of the bay	30-Apr-99				12		
UAR 27611	UAM Cat# 50509	Muscle/ EtOH	M		Kodiak	Kalsin Bay; 5 mi up Olds River	01-May-98		CR9		14		
UAR 27612	UAM Cat# 50510	Brain&Muscle/ EtOH	M		Kodiak	N of Karluk River	25-Apr-99		CR20		14		
UAR 27613	UAM Cat# 50511	Muscle/ EtOH	F		Afognak	Afognak Is	05-May-99		CR30	DQB1	14		
UAR 27614	UAM Cat# 50512	Brain&Muscle/ EtOH	M		Kodiak	Larsen Bay (village)	02-May-99		CR20		14		
UAR 27615	UAM Cat# 50513	Muscle/ EtOH	Unk		Afognak	Kitoi Bay	06-May-99		CR30	DQB1	14		
UAR 27616	UAM Cat# 50514	Muscle/ EtOH	M		Afognak	Raspberry Strait	05-May-99		CR30	DQB1	14		
UAR 27617	UAM Cat# 50515	Brain&Muscle/ EtOH	M		Kodiak	Uyak Bay	05-May-99		CR30		14		

UAR 27618	UAM Cat# 50516	Brain&Muscle/ EtOH	F		Kodiak	Chief Cove	04-May-99		CR30		14		
UAR 27619	UAM Cat# 50517	Brain&Muscle/ EtOH	F		Kodiak	Deadman Bay	04-May-99		CR9		14		
UAR 27620	UAM Cat# 50518	Brain&Muscle/ EtOH	M		Kodiak	Halibut Bay	04-May-99		CR20		14		
UAR 27621	UAM Cat# 50519	Muscle/ EtOH	M		Afognak	Malina Bay, S side	04-May-99		CR30	DQB1 DQB1	14		
UAR 27622	UAM Cat# 50520	Brain&Muscle/ EtOH	M		Kodiak	Uyak Bay	07-May-99				14		
UAR 27623	UAM Cat# 50521	Brain&Muscle/ EtOH	M		Kodiak	Ayakulik R	04-May-99		CR30		14		
UAR 27624	UAM Cat# 50522	Brain&Muscle/ EtOH	M		Kodiak	Red Lake	05-May-99			DQB1	14		
UAR 27625	UAM Cat# 50523	Brain&Muscle/ EtOH	M		Kodiak	Red Lake	07-May-99				14		
UAR 27626	UAM Cat# 50524	Brain&Muscle/ EtOH	M		Kodiak	Terror Bay	06-May-99		CR30		14		
UAR 27627	UAM Cat# 50525	Brain&Muscle/ EtOH	F		Kodiak	Frazer Lake; Middle Creek	04-May-99		CR32		14		
UAR 27628	UAM Cat# 50526	Brain&Muscle/ EtOH	F		Kodiak	Horse Marine Lagoon	08-May-99		CR32		13		
UAR 27629	UAM Cat# 50527	Brain&Muscle/ EtOH	M		Kodiak	Kodiak	07-May-99		CR9	DQB1	14		
UAR 27630	UAM Cat# 50528	Brain&Muscle/ EtOH	F		Kodiak	Aliulik Peninsula; Cape Trinity	11-May-99		CR9	DQB1	14		
UAR 27631	UAM Cat# 50529	Brain&Muscle/ EtOH	F		Kodiak	Frazer Lake; Middle Creek	12-May-99		CR20	DQB1	14		
UAR 27632	UAM Cat# 50530	Brain&Muscle/ EtOH	M		Kodiak	Seven Rivers; Aliulik Peninsula	15-May-99		CR9	DQB1	14		
UAR 27633	UAM Cat# 50531	Brain&Muscle/ EtOH	Unk		Kodiak	E fork of the Dog Salmon R	15-May-99		CR9				
UAR 510407	510407	Muscle/ EtOH	M	6	Kodiak	East Fork Ayakulik River	25-Apr-93	311					
UAR 510452	510452	Muscle/ EtOH	F	4	Kodiak	Barling Bay	05-May-93	318					

UAR 510453	510453	Muscle/ EtOH	M	15	Afognak	Afognak Is., Dolphin Point	08-May-93	206					
UAR 510456	510456	Muscle/ EtOH	F	5	Kodiak	Uganik Lake, midway along lake	06-May-93	304					
UAR 510468	510468	Muscle/ EtOH	M	13	Afognak	Afognak Is., Marmot Strait	07-May-93	211					
UAR 510475	510475	Muscle/ EtOH	M	18	Kodiak	Ugak Bay, Eagle Harbor	14-May-93	321					
UAR 510572	510572	Muscle/ EtOH	F	5	Kodiak	Uganik Bay, South Arm, 2 mi up	01-May-93	304					
UAR 510651	510651	Muscle/ EtOH	M	14	Kodiak	Viekoda Bay, south side	16-Apr-93	301					
UAR 510653	510653	Muscle/ EtOH	M	15	Kodiak	Dog Salmon River	17-Apr-93	313					
UAR 510660	510660	Muscle/ EtOH	F	3	Kodiak	Middle Bay, American River	23-Apr-93	328					
UAR 510664	510664	Muscle/ EtOH	F	14	Kodiak	Deadman Bay, Hepburn Pen.	24-Apr-93	315					
UAR 510668	510668	Muscle/ EtOH	F	23	Kodiak	Terror River, SW side, 4 mi up	24-Apr-93	305					
UAR 510676	510676	Muscle/ EtOH	F	4	Kodiak	Spiridon Bay, head of bay	01-May-93	306					
UAR 510680	510680	Muscle/ EtOH	M	12	Kodiak	Karluk Lake, Falls Creek	20-Apr-93	310					
UAR 510686	510686	Muscle/ EtOH	F	4	Kodiak	Uganik Island, behind KNWR cabin	30-Apr-93	303					
UAR 510688	510688	Muscle/ EtOH	M	9	Kodiak	Sturgeon River, 6 mi upriver	28-Apr-93	311					
UAR 510690	610690	Muscle/ EtOH	M	16	Kodiak	Alitak Bay, Aliulik Pen, Cape Trinity	04-May-93	316					
UAR 510691	510691	Muscle/ EtOH	M	11	Kodiak	Uyak Bay, south of Larsen Bay	04-May-93	308					
UAR 510697	510697	Muscle/ EtOH	F	8	Kodiak	Portage Bay, south side of mouth	06-May-93	316					
UAR 74338	74338		M	6	Kodiak	Moser Bay	24-Apr-91	314	CR9		14		

UAR 74342	74342		M	6	Kodiak	Deadman Bay, N.side Alpine Cove	26-Apr-91	315	CR30		14		
UAR 74343	74343		F	3	Kodiak	Deadman Bay, Alpine Cove	26-Apr-91	315					
UAR 74344	74344		F	4	Kodiak	Pasagshak Bay, Lake Rose Tead	28-Apr-91	327	CR30		14		
UAR 74345	74345		M	8	Kodiak	Portage Bay	28-Apr-91	316	CR9		14		
UAR 74350	74350		F	4	Kodiak	Terror Bay, Baumann Creek	28-Apr-91	302	CR30	DQB1	14		
UAR 74440	74440		M	15	Kodiak	Frazer Lk, north end	30-Apr-91	313					
UAR 74446	74446		M	13	Kodiak	Uyak Bay, S. Uyak Creek	08-May-91	308					
UAR 74450	74450		M	14	Kodiak	Karluk Lk	07-May-91	310	CR20		14		
UAR 74496	74UAM Cat# UAM Cat# 496		F	4	Afognak	Afognak Is, N of Portage Lake	29-Apr-92	213	CR30	DQB1	13		
UAR 74497	74UAM Cat# UAM Cat# 497		M	3	Afognak	Perenosa Bay, Afognak Is	28-Apr-92	213	CR30	DQB1	14		
UAR 74500	74500		F	4	Kodiak	Red Lk, NW Drainage	24-Apr-91	312	CR9		14		
UAR 74784	74784												
UAR 74996	7UAM Cat# UAM Cat# 4996		F				29-Apr-91						
UAR 74997	7UAM Cat# UAM Cat# 4997		M				28-Apr-91						
UAR 76032	76932		F	3	Kodiak	Red Lake, south end	04-May-92	312					
UAR 76763	76763		F	11	Kodiak	Karluk Lk/Thumb Lk	23-Apr-92	310	CR20		14		
UAR 76764	76764		M	7	Kodiak	Karluk Lk, Meadow Cr	22-Apr-92	310	CR32		14		
UAR 76769	76769		F	4	Afognak	Afognak Is., Marmot Strait	13-May-92	211					
UAR 76801	76801		M	9	Kodiak	Karluk Lake, Canyon Creek	28-Apr-91	310	CR20		14		

UAR 76822	76822		F	8	Kodiak	Uyak Bay, N of Deadman Pass	25-Apr-92	308					
UAR 76824	76824		M	13	Kodiak	Cape Trinity, Aliulik Peninsula	25-Apr-92	316	CR9		14		
UAR 76825	76825		F	4	Afognak	Seal Bay, Afognak Is	28-Apr-92	212	CR30	DQB1	14		
UAR 76827	76827		F	4	Kodiak	Uyak Bay, head of Bay	30-Apr-92	308					
UAR 76840	76840		M	10	Kodiak	Kizhuyak Bay, west side	08-May-92	301					
UAR 76911	76911		F	4	Kodiak	Middle Bay, American River	26-Apr-92	328					
UAR 76914	76914		F	7	Kodiak	Karluk Lk, Halfway Cr	28-Apr-92	310	CR9		14		
UAR 76915	76915		M	11	Kodiak	Portage Bay	28-Apr-92	316					
UAR 76916	76916		F	22	Afognak	Afognak Is, Seal Bay	29-Apr-92	212					
UAR 76919	76919		M	15	Kodiak	Uganik Lake, 3 mi upriver	30-Apr-92	305					
UAR 76922	76922		M	11	Kodiak	Kaguyak Bay (old village site)	01-May-92	316					
UAR 76924	76924		F	4	Afognak	Malina Ck, Afognak Is	29-Apr-92	206					
UAR 76926	76926		F	5	Kodiak	Frazer Lake, mid-lake, east side	02-May-92	313					
UAR 76927	76927		F	3	Kodiak	Red Lake, NE side	05-May-92	312					
UAR 76928	76928		F	7	Kodiak	Uganik Lk, 2 mi. upriver	05-May-92	305					
UAR 76930	76930		M	7	Kodiak	Karluk River, near Portage	30-Apr-92	309	CR20		14		
UAR 76931	76931		M	9	Kodiak	Karluk River, 5 mi below Shasta	05-May-92	309	CR20		14		
UAR 76932			F										
UAR 76933	76933		F	3	Kodiak	Red Lake, south end	01-May-92	312					

UAR KOD207		Blood/ Urea Buf	M	7	Kodiak	Aliulik Peninsula	17-May-93	316						Capture
UAR KOD218		Blood/ Urea Buf	M	14	Kodiak	Aliulik Pen, E of Twin Peaks	17-May-93	316						Capture
UAR KOD219		Blood/ Urea Buf	F	3	Kodiak	Aliulik Pen, Humpy Cove	17-May-93	316						Capture
UAR KOD220		Blood/ Urea Buf	F	20	Kodiak	Aliulik Pen, Hawk Bluff	17-May-93	316						Capture
UAR KOD221		Blood/ Urea Buf	F	14	Kodiak	Aliulik Pen, Hawk Bluff	17-May-93	316						Capture
UAR KOD222		Blood/ Urea Buf	F	13	Kodiak	Aliulik Pen, mouth of Russian Har.	17-May-93	316						Capture
UAR KOD223		Blood/ Urea Buf	M	10	Kodiak	Head of Portage Bay	17-May-93	316	CR9		11			Capture
UAR KOD224		Blood/ Urea Buf	F	10	Kodiak	1.5 mi west of Jap Bay	17-May-93	316						Capture
UAR KOD225		Blood/ Urea Buf	F	8	Kodiak	2.5 mi W of old Kaguyak village	18-May-93	316						Capture
UAR KOD226		Blood/ Urea Buf	F	7	Kodiak	Aliulik Peninsula	20-May-93	316	CR9					Capture
UAR KOD227		Blood/ Urea Buf	M	5	Kodiak	Aliulik Pen, E of Twin Peaks	20-May-93	316						Capture
UAR KOD228		Blood/ Urea Buf	M	8	Kodiak	Aliulik Pen, Seven Rivers	20-May-93	316	CR9		13			Capture
UAR KOD229		Blood/ Urea Buf	F	11	Kodiak	Aliulik Pen, Seven Rivers	20-May-93	316	CR9		11			Capture
UAR KOD230		Blood/ Urea Buf	M	9	Kodiak	Aliulik Pen, mouth of Russian Har.	20-May-93	316						Capture
UAR KOD231		Blood/ Urea Buf	F	5	Kodiak	Aliulik Pen, mouth of Russian Har.	20-May-93	316						Capture
UAR KOD232		Blood/ Urea Buf	F	4	Kodiak	Aliulik Peninsula	20-May-93	316	CR9		14			Capture
UAR KOD233		Blood/ Urea Buf	F	10	Kodiak	head of Jap Bay	20-May-93	316						Capture
UAR KOD234		Blood/ Urea Buf	F	3	Kodiak	Aliulik Pen, Hawk Bluff	21-May-93	316						Capture
UAR KOD235		Blood/ Urea Buf	F	4	Kodiak	Aliulik Pen, Hawk Bluff	21-May-93	316						Capture

**APPENDIX 2
MATCH STATISTICS**

Appendix 2. Data associated with 14 bears sharing identical multilocus genotypes with at least one other individual. Samples listed under “Sample 1” matched at all alleles with samples listed under “Sample 2”. “Score” is the percentage of samples matching, “No. Alleles” is the number of alleles compared, and “No. Matched” is the number of matching samples. Field data are included for each pairwise comparison to demonstrate that samples matching at all loci, in most cases, can still be differentiated based on date of harvest, estimated age of birth, and/or sex.

Matching Samples

Match Statistics

Matching Samples					Match Statistics					
Sample 1	Year Harvested	Est. Year of Birth	Sex	Sample 2	Year Harvested	Est. Year of Birth	Sex	Score	No. Alleles	No. Matched
1-1	Kod07912	2003	M	1-2	Kod20745	2004	F	100.00%	28	28
2-1	Kod07912	2003	M	2-2	Kod74345	1991	M	100.00%	28	28
3-1	Kod20342	2003	F	3-2	Kod27589	1998	M	100.00%	28	28
4-1	Kod27586	1998	M	4-2	Kod17027	2004	F	100.00%	28	28
5-1	Kod27633	1999	Unk	5-2	Kod510673	1993	M	100.00%	28	28
6-1	Kod22665	1998	M	6-2	Kod17033	2004	F	100.00%	28	28
7-1	Kod20295	2004	M	7-2	Kod20714	2004	F	100.00%	28	28
8-1	Kod20745	2004	F	8-2	Kod74345	1991	M	100.00%	28	28
9-1	Kod22655	1998	M	9-2	Kod226	n/a	F	100.00%	22	22

APPENDIX 3
BROWN BEAR MHC DQA1 SEQUENCES

Appendix 3. Nucleotide sequences of the brown bear class II MHC DQA1 locus, shown here for two bears from southcentral Alaska (SCEN), one from Katmai National Park (KAT), and three from Kodiak Island (KOD). Sequences include the 3' portion of exon 2, the entire exon 3, and the 5' portion of exon 4, and associated introns. Single letters and dots below the nucleotide sequences represent site substitutions that are, respectively, different or distinct from the southcentral Alaska sample SCEN16011. Numbers above the nucleotides are the numerical positions of the sites, read vertically. Letters above site numbers represent amino acid translations of codons for exon sequences. Borders between each domain are indicated by arrows, based on sequence homology with *Zalophus californianus* (Zaca-DQA-01; Bowen et al. 2002, data not shown).

Table with columns for amino acid translations (Y, V, D, L, E, K, K, E, T, V, W, R, L, P, V, F, S, T, F, R, S, F, D, P, Q, G) and nucleotide sequences for samples SCEN16011, SCEN16013, KAT329, KODA27629, KODA27630, and KODA27631. Includes labels for Exon 2 and Exon 3.

Appendix 3 continued.

	V	C	A	C	G
	111	111	111	111	111
	111	111	111	111	111
	788	888	888	889	999
	901	234	567	890	123
SCEN16011	GTC	TGT	GCC	TGC	GGT
SCEN16013
KAT329
KODA27629
KODA27630
KODA27631
