

## **APPENDIX D**

### **Identification and Evaluation of Time-Dependent Route Geohazards**

- Page Intentionally Left Blank -



# ALASKA STAND ALONE PIPELINE/*ASAP* PROJECT

## Identification and Evaluation of Time-Dependent Route Geohazards

ASAP-27-RTA-YYY-DOC-00023  
January 15, 2018

**NOTICE**

THIS DOCUMENT CONTAINS CONFIDENTIAL AND PROPRIETARY INFORMATION AND SHALL NOT BE DUPLICATED, DISTRIBUTED, DISCLOSED, SHARED OR USED FOR ANY PURPOSE EXCEPT AS MAY BE AUTHORIZED BY AGDC IN WRITING.

©2018 Alaska Gasline Development Corporation. All rights reserved.

Alaska Gasline Development Corporation  
3201 C Street, Suite 200  
Anchorage, AK 99503  
[www.agdc.us](http://www.agdc.us)  
907-330-6300

## REVISION HISTORY

Revision	Date	Description of Revision	Author	Approval	
				Company Preparing Report	ASAP Senior Project Manager
0	5/10/2016	Issued for Use	KJM/SDL/KOS/RC	AGDC	David Haugen
1	7/8/2016	Revised based on USACOE comments	KJM/SDL/RC	AGDC	David Haugen
2	1/15/2018	Revised to reflect SBD is not anticipated	Paul Carson	MBJ	David Haugen

## EXECUTIVE SUMMARY

The purpose of this report is to update the document *Design Methodology to Address Frost Heave Potential* (ASAP-27-RTA-GGG-DOC-00011) June 9, 2011. Consistent with the original document, this update document provides the Alaska Stand Alone Gas Pipeline/ASAP (ASAP) design methodology to address potential threats related to time-dependent pipeline integrity threats. The subject matter has been updated to address the current ASAP Project configuration and design approach. The potential threats addressed in this document are termed ‘thaw settlement’ for thawing and subsequent consolidation of initially frozen soils, and ‘frost heave’ for freezing and soil expansion of an initially unfrozen soil. Specifically, this report introduces the ASAP approach to the structural mechanics issues of the pipeline for these threats which form over an extended period of time (i.e. ‘time-dependent threats’), and address the methodology employed to ensure pipeline mechanical structural integrity when subjected to potential displacements associated with these time-dependent earth movements.

The ASAP Project methodology to ensure pipeline integrity from time-dependent threats depends on the evaluation of a limiting longitudinal strain of the pipe. The limiting longitudinal strain of the pipe is used for design screening of the route terrain units and developing operational monitoring requirements using pipeline in-line inspection (ILI) tools that detect pipeline movement (e.g., high resolution geometry pigs). The limiting strain criteria is derived from consideration of limiting tensile and compressive strains capacities of the pipe material. This criterion is used to screen pipe route segments which do not exceed the criteria limits, after evaluation of the interaction of the pipe material, its operating characteristics, and the segment route subsurface behavior. Those segments that are determined to potentially exceed the criteria limits are subject to mitigative actions to reduce the pipe response to within acceptable bounds.

Sections 1 through 5 introduce the ASAP design terminology as it applies to this effort. In particular, these chapters summarize the development of the methodology that employs strain limits to ensure pipeline structural integrity for those displacement-controlled loadings that induce transverse bending. The introductory material includes background on the determination of the loading, the geothermal analytical methodology used to evaluate the loading, its associated soil and pipe resisting functions, and how these are integrated in a combined pipe-soil interaction analysis. The analytical process measures the effect of the loading and soil resisting functions on pipe response against quantitative structural integrity criteria for the range of route soils to be encountered as well as a range of operational conditions. This evaluation process for the range of alignment conditions forms the demand evaluation, i.e. the ‘demand’ for structural capacity to resist this imposed displacement load. This ‘demand’ is then compared against the available ‘capacity’ of the pipe to resist this demand. When the measurement metric is the strain developed in the linepipe, these are appropriately termed ‘strain demand’ and ‘strain capacity.’ These concepts are the basis of the approach termed Strain Based Design (SBD), which could be implemented in areas where the strain demand magnitude is anticipated to exceed 0.5%, or for mitigation measures, such as the selective use of heavier-walled pipe where strain demand might exceed this limit. Currently, the Project intends to use heavier-walled pipe in select locations as a mitigation measure to address potential strain demand exceedances rather than SBD.

Section 6 focuses on the line pipe material and fabrication, and the corresponding development of appropriate design limits using these materials. These limits are used as the resistance pipe

capacity and are used to judge the acceptance or rejection of the demand developed in the previous chapters. Section 6 then addresses the questions:

- How are the strain capacity limits to be developed?
- What tests will be conducted to verify the limits?
- What material requirements will be imposed?

Section 7 outlines the application of the design methodology to the alignment. This includes an introduction to the alignment conditions where the loadings under consideration in this report, thaw settlement and frost heave, could be expected to occur and those areas where these phenomena are not expected to occur. The application methodology is presented as a progressive exclusion sieve, narrowing down the alignment conditions, and associated alignment geographical segments, where the concern needs more detailed evaluation and potential mitigation. This chapter addresses the questions:

- Where might mitigation measures (e.g., heavier-walled pipe, SBD approach, etc.) be needed?

Section 8 addresses construction requirements relating to anticipation of route hazard mitigation, answering the question:

- What modifications to standard construction techniques will be needed?

Section 9 addresses potential operational mitigative methods if operational monitoring concludes the established limits may be exceeded and pipeline integrity is at risk. This chapter addresses the questions:

- What monitoring will be required during operations to ensure the limits are not exceeded?
- What mitigation measures will be employed should the limits be approached or exceeded?

Alaska Gasline Development Corporation (AGDC) has furthered the development of the methodology to address these potential pipeline integrity threats. This is a process continuing to final design, and then into deployment throughout the operational life of the pipeline. AGDC is confident the process presented herein addresses the design methodology requirements needed for design, and forms a framework for successful deployment of the approach.

## ACRONYMS AND ABBREVIATIONS

1D	One-dimensional
ADOT&PF	Alaska Department of Transportation and Public Facilities
AGDC	Alaska Gasline Development Corporation
API	American Petroleum Institute
ASAP	Alaska Stand Alone Gas Pipeline
ASME	American Society of Mechanical Engineers
ASTM	American Standard Testing Materials
AUT	Automated ultrasonic testing
bgs	Below ground surface
cf	Cubic feet
CFR	Code of Federal Regulations
CWPT	Curved wide plate testing
DGGS	State of Alaska Division of Geological and Geophysical Surveys
FDCM	Field Design Change Manual
FEA	Finite element analyses
FEL	Front end loading
FSD	Fairbanks surface disturbance
GCF	Gas Conditioning Facility
GIS	Geographic Information System
HC	Hoop compression
HDD	Horizontal directional drill(ing)
HT	Hoop tension
ILI	In-Line Inspection
INS	Inertial Navigation System
ksi	Kips per square inch
LT	Longitudinal tension
MAGT	Mean annual ground temperature
MAOP	Maximum allowable operating pressure
MP	Milepost
NWA	Northwest Alaskan Pipeline Company

PHMSA	Pipeline and Hazardous Materials Safety Administration
PIPLIN	SSD Inc. pipeline analysis software
psig	Pounds per square inch gage
ROW	Right-of-way
SBD	Strain Based Design
SEB	Surface energy balance
SMYS	Specified minimum yield strength
SRP	Revegetation and stabilization plan
TAPS	Trans-Alaska Pipeline System
UOE	Uing and Oing forming of pipe
U.S.	United States of America
UAF	University of Alaska Fairbanks
USACE	U.S. Army Corps of Engineers
USCS	Unified Soil Classification System
USGS	U.S. Geological Survey

**TABLE OF CONTENTS**

**Notice .....1**

**Revision History .....2**

**Executive Summary .....3**

**Acronyms and Abbreviations.....5**

**1. Introduction .....11**

    1.1 Project Overview ..... 11

    1.2 Project Phasing and Associated Deliverables ..... 14

        1.2.1 Design Deliverables..... 15

    1.3 Organization of the Report ..... 17

**2. Geohazards Overview .....19**

    2.1 Geothermal Considerations..... 19

    2.2 Design Development ..... 21

        2.2.1 Geotechnical data ..... 21

        2.2.2 Geotechnical and Geothermal Parameters for Design..... 21

        2.2.3 Application of Methodology ..... 24

**3. Geothermal Methodology .....25**

    3.1 Geothermal Analysis Overview ..... 25

    3.2 Modeling Subsurface Geothermal Conditions..... 25

        3.2.1 General Modeling Approach ..... 25

        3.2.2 Domain Geometry ..... 26

        3.2.3 Soil Properties ..... 27

        3.2.4 Initial Conditions ..... 28

        3.2.5 Ground Surface Boundary Condition ..... 28

        3.2.6 Climate Data ..... 29

        3.2.7 Pipe Temperature Boundary Condition..... 29

        3.2.8 Periodic Steady-State..... 29

    3.3 Relationship between Climate and the Surface and Subsurface Conditions ..... 30

    3.4 Route data requirements ..... 35

    3.5 Model Calibration ..... 35

        3.5.1 Calibration to Mean Annual Ground Temperature..... 35

        3.5.2 Calibration of Long-Term Thaw Depth from Ground Surface Disturbance ..... 36

    3.6 Sample Results..... 38

**4. Structural Mechanics of Buried Pipelines .....39**

    4.1 Pressure Containment ..... 40

    4.2 Treatment of Longitudinal Loadings ..... 40

    4.3 Effective Stress ..... 41

    4.4 Critical Span ..... 44

    4.5 Application of the Methodology..... 48

**5. Strain Demand Determination.....49**

- 5.1 Pipe-Soil Interaction Analysis Overview..... 49
- 5.2 Pipe Material Properties..... 52
- 5.3 Geothermal Input ..... 53
  - 5.3.1 Frost Heave..... 53
  - 5.3.2 Thaw Settlement..... 56
- 5.4 Soil Resistance Characterization ..... 56
  - 5.4.1 Uplift Resistance for Frost Heave ..... 57
  - 5.4.2 Bearing Resistance ..... 58
  - 5.4.3 Longitudinal Resistance ..... 58
- 5.5 Model Geometry ..... 59
- 5.6 Imposed Loads..... 60
  - 5.6.1 Frost Heave..... 60
  - 5.6.2 Thaw settlement..... 61
  - 5.6.3 PIPLIN Output for Pipe Resultants ..... 61
- 6. Strain Capacity Determination.....63**
  - 6.1 Material Requirements..... 63
    - 6.1.1 Line Pipe..... 63
    - 6.1.2 Coating Effect..... 66
    - 6.1.3 Dimensional Control ..... 67
    - 6.1.4 Girth Welds ..... 67
    - 6.1.5 Weld Overmatch..... 67
    - 6.1.6 Weldment Toughness ..... 67
  - 6.2 Testing Requirements ..... 68
    - 6.2.1 Curved Wide Plate Testing..... 68
    - 6.2.2 Full-Scale Tension Testing..... 68
    - 6.2.3 Compressive Strain Validation..... 68
- 7. Route Application.....70**
  - 7.1 General Overview ..... 70
  - 7.2 Geotechnical Program..... 71
  - 7.3 Thaw Settlement ..... 71
    - 7.3.1 Design Approach and Analysis ..... 71
    - 7.3.2 Segment by Segment Design..... 76
    - 7.3.3 Thermal Simulations ..... 81
    - 7.3.4 Thaw Settlement Methodology ..... 81
    - 7.3.5 Potential Design Mitigative Measures for Thaw Settlement ..... 82
  - 7.4 Frost Heave ..... 83
    - 7.4.1 Design Approach ..... 83
    - 7.4.2 Design Parameters ..... 85
    - 7.4.3 Analysis ..... 85
    - 7.4.4 Segment by Segment Design..... 86
    - 7.4.5 Potential Design Mitigative Measures for Frost Heave..... 86
- 8. Construction Related Issues .....88**
  - 8.1 Construction Seasonality and ROW Mode ..... 88
  - 8.2 Girth Weld Qualification Procedures..... 88
  - 8.3 Automated Ultrasonic Testing ..... 88
  - 8.4 Unexpected Subsurface Conditions ..... 89

**9. Operations and Maintenance .....90**

9.1 Monitoring ..... 90

9.2 Potential Operational Mitigative Measures ..... 91

9.2.1 Revegetation..... 92

9.2.2 Temperature Control ..... 94

9.2.3 Line Leveling..... 95

**10. Conclusion.....96**

**11. References.....97**

**Appendix A: Structural Mechanics of Buried Pipelines**

**Appendix B: Expected Long-Term Thaw Depths in Warm Permafrost on the ASAP Row  
Technical Memorandum**

**LIST OF TABLES**

Table 1. USACE Frost Design Soil Classification System..... 22

Table 2. Geotechnical Tests for Frost Heave Potential..... 22

Table 3. Additional Geotechnical Tests for Frost Heave Evaluation..... 23

Table 4. Soil Index and Thermal Properties ..... 28

**LIST OF FIGURES**

Figure 1. v6.1 Mainline Route Map ..... 13

Figure 2. Fairbanks Lateral Route Map..... 14

Figure 3. Design Approach Flowchart ..... 16

Figure 4. Permafrost Characteristics ..... 20

Figure 5. Geothermal Model Domain and Finite Element Mesh ..... 26

Figure 6. Geothermal Model in the Near Vicinity of the Pipe ..... 27

Figure 7. Comparison of Measured and Model-Computed Ground Surface Net-Flux, FSD Test Site, Undisturbed Terrain..... 32

Figure 8. Model-Computed SEB Flux Components, FSD Test Site, Undisturbed Terrain ..... 33

Figure 9. Model-Computed Ground and Snow Surface Temperatures, FSD Test Site, Undisturbed Terrain..... 34

Figure 10. Geothermal Model Calibration to Target MAGT ..... 36

Figure 11. Geothermal Model Surface Disturbance Calibration..... 38

Figure 12. Illustration of Tresca and von Mises Yield Functions ..... 43

Figure 13. Pipe bridging over a Short Settlement Span ..... 44

Figure 14. Maximum Pipe Strain Value – ‘Bridging’ Through the Imposed Settlement Span .. 45

Figure 15. Long Span Differential Settlement ..... 45

Figure 16. Critical Span Evaluation Example ..... 47

Figure 17. Differential Frost Heave ..... 50

Figure 18. Differential Thaw Settlement and Model ..... 51

Figure 19. Frost Bulb Schematic ..... 54

Figure 20. Thaw Span Block..... 59

Figure 21. Illustration of Maximum Curvature Time History ..... 62

Figure 22. Normative Properties of a Steel Stress-Strain Relationship..... 64

Figure 23. Illustration of Differing Stress-Strain Behavior in the Knee Region..... 65

Figure 24. Thaw Potential with Various Surface Cover (CRREL)..... 73

Figure 25. CRREL Site in Fairbanks Alaska ..... 74

Figure 26. Terrain Unit Map ..... 77

Figure 27. Typical Borehole Log ..... 78

Figure 28. Revegetation of Kanuti Pit, Photo Point 3 ..... 93

Figure 29. TAPS Buried Segment with Thermosyphons ..... 94

Figure 30. TAPS Aboveground Pipeline with Thermosyphons ..... 95

## 1. INTRODUCTION

The purpose of this report is to introduce the design methodology for addressing potential route threats related to changes in the subsurface thermal state resulting in trench displacement and consequent bending of the pipe. These potential threats are termed ‘thaw settlement’ for thawing and subsequent consolidation of initially frozen soils, and ‘frost heave’ for freezing and soil expansion of an initially unfrozen soil. Specifically, this report introduces the ASAP approach to the structural mechanics issues of the pipeline for these threats which form over an extended period of time (i.e. ‘time-dependent threats’), and address the methodology employed to ensure pipeline mechanical structural integrity when subjected to potential displacements associated with these time-dependent earth movements.

Potential threats to the pipeline integrity are generally identified and assessed using American Society of Mechanical Engineers (ASME) B31.8S, Managing System Integrity of Gas Pipelines, which has an overview of a generalized procedure to the approach to earth movement threats contained in Section A-9, *Weather Related and Outside Force Threat (Earth Movement, Heavy Rains or Floods, Cold Weather, Lightning)*. The potential pipeline displacement loadings from earth movement used to illustrate the approach in this report are thaw settlement and frost heave. Note that both thaw settlement and frost heave are time-dependent threats, which are different from other familiar earth movement threats, such as seismicity, which are time-independent.

Presentation of the design methodology addresses the design approach required by the Pipeline and Hazardous Materials Safety Administration (PHMSA) in correspondence to ASAP (or the Project) and in meetings between PHMSA and the ASAP technical team. Appendix A contains the draft provisions which would govern the deployment of the SBD methodology for high strain areas, should SBD be incorporated. Currently, heavier-walled pipe is planned as a mitigative measure rather than the use of SBD.

### 1.1 PROJECT OVERVIEW

The ASAP Project comprises a Gas Conditioning Facility (GCF) near Prudhoe Bay capable of producing an annual average of 500 million standard cubic feet per day of natural gas; a 36-inch diameter, 733-mile-long, buried natural gas pipeline, with a maximum allowable operating pressure (MAOP) of 1,480 pounds per square inch (psig), connecting the GCF to the existing ENSTAR Natural Gas Company (ENSTAR) pipeline system in the Matanuska-Susitna Borough; a 12-inch nominal diameter, 30-mile-long, buried lateral line, with an MAOP of 1,480 psig, connecting the Mainline to Fairbanks; and associated facilities. The pipeline system will be designed to transport natural gas that will be accessible to and useable by communities, government entities, and natural resource development projects. Compression of the gas for transmission is completed at the North Slope – that is, there is no further compression and thus no intermediate compressor stations along the route.

The proposed pipeline will typically be buried with a minimum cover of 30 inches and a bottom-of-ditch depth of approximately 6 to 8 feet, except at fault crossings, elevated bridge stream crossings, pigging facilities, and block valve locations. The ASAP route will generally parallel the Trans-Alaska Pipeline System (TAPS) and Dalton Highway corridor to near Livengood, northwest of Fairbanks. At Livengood, the route will continue south, to the west of Fairbanks and Nenana. The pipeline will bypass Denali National Park to the east and will then generally parallel the Parks

Highway corridor to Willow, continuing south to its connection with ENSTAR's distribution system at Milepost (MP) 39 of the Beluga Pipeline, southwest of Big Lake as shown in Figure 1. The Fairbanks Lateral tie-in will be located approximately 2.5 miles south of the Mainline Chatanika River crossing at MP 440 of the Mainline. From the tie-in, the Fairbanks Lateral pipeline will traverse east, following the Murphy Dome and Old Murphy Dome Roads, and then extending southeast into Fairbanks as shown in Figure 2.

The Mainline will be constructed of American Petroleum Institute (API) 5L X70 pipe with a minimum wall thickness of 0.527 inches (Class 1), for the MAOP of 1,480 psig, which corresponds to a design factor of 0.72 for Class 1 locations (not subject to special provisions as per 49 Code of Federal Regulations (CFR) 192.111). There is no intention of utilizing the alternative MAOP provisions of the 49 CFR 192 regulations which allow an increase of the design factor to 0.80. The Fairbanks Lateral will be constructed of API 5L X52 pipe with a minimum wall thickness of 0.330 inches for the MAOP of 1480 psig.

Figure 1. v6.1 Mainline Route Map

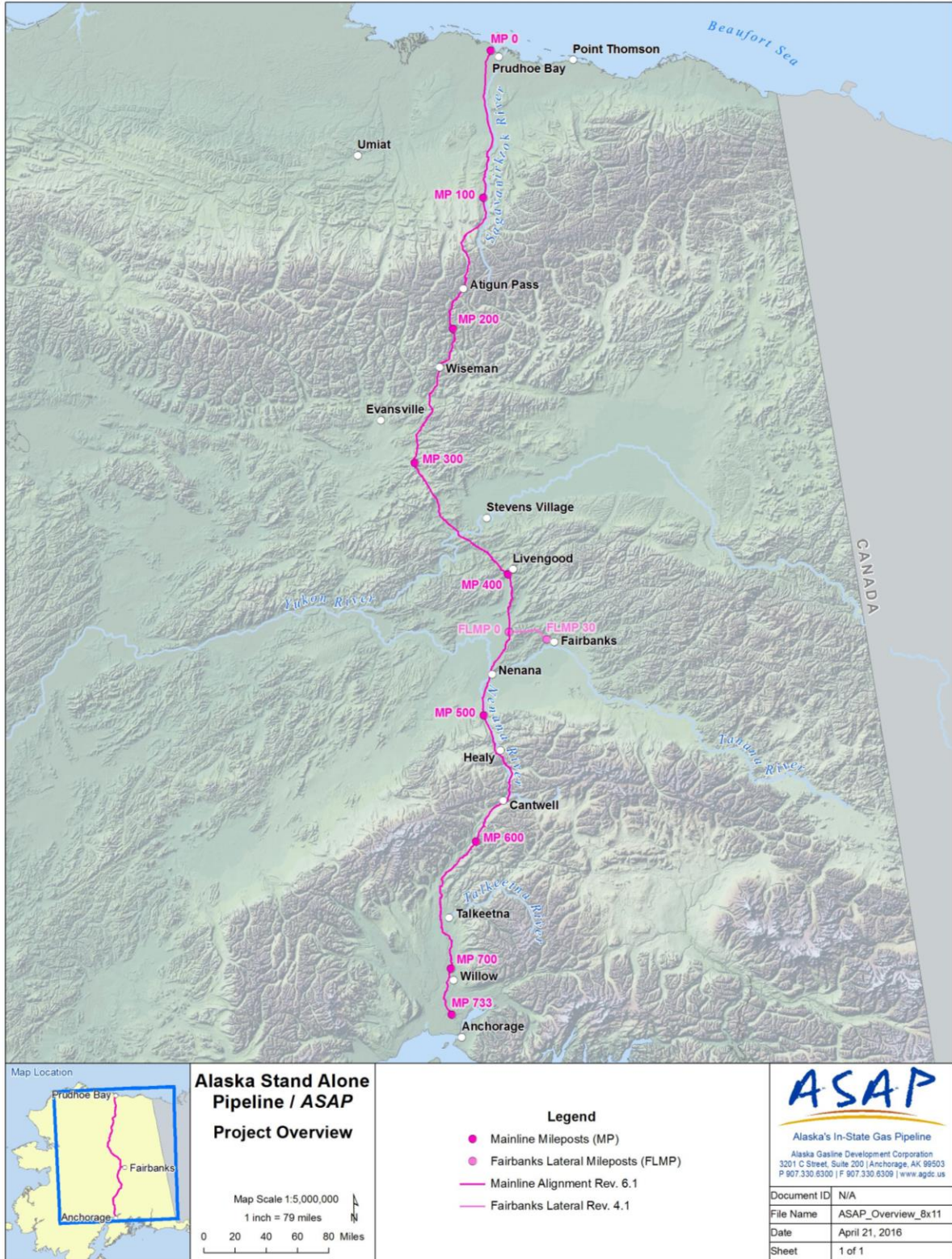
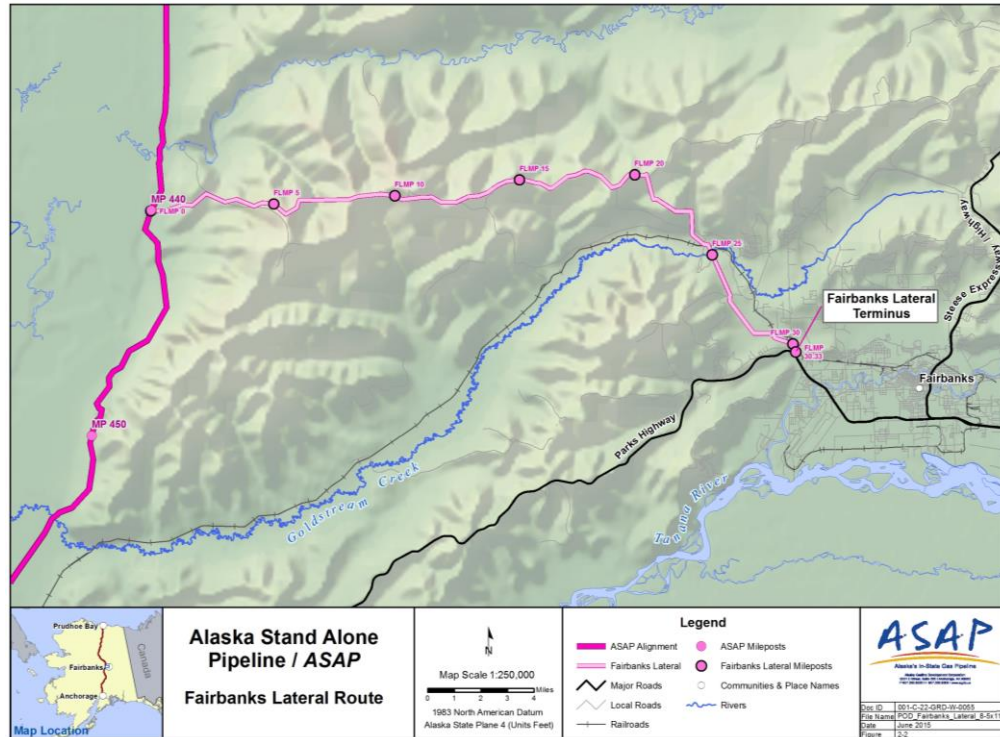

Figure 2. Fairbanks Lateral Route Map



1.2 PROJECT PHASING AND ASSOCIATED DELIVERABLES

Research shows the disciplined application of a stage-gated process is strongly correlated with producing superior project outcomes. The gated approach involves breaking a capital project into discretely defined phases, where a clear set of deliverables or outcomes is outlined for each phase, which must be completed before the project is approved to move into the next phase. AGDC will be employing a stage-gated approach to project execution and delivery.

The first major phase of the gated project delivery process is FEL (front-end loading). Three stages usually comprise the FEL process (Conceptual Engineering, Preliminary Design, and Detailed Design) prior to project sanction (start of Execution). ASAP is currently completing the second phase of FEL (termed FEL-2).

The results of the FEL phases provide critical input for making the final authorization decision to move forward with the project. The primary objective of FEL is to achieve an understanding of the project that is sufficiently detailed so that significant and costly changes in engineering, construction, and the startup phases of a project will be minimized.

As the Project progresses into Detailed Design, development of a large integrated project team will be needed comprised of people with a wide range of capabilities that can perform key functional roles in the project team organization. Project skill sets that will be required to move

the project forward include operations, maintenance, business, process design, project controls, construction management, procurement and contracting, quality assurance, health and safety, and permitting.

### 1.2.1 Design Deliverables

The design approach for the time-dependent threats of frost heave and thaw settlement is depicted in Figure 3 and will be explained further throughout this report. As the design progresses from FEL-2 through Detailed Design and then Construction, information is being collated and verified to allow the design to progress along this design approach flowchart. ASAP Design has followed the methodology development – scoping the data collection required for the demand and capacity to be further verified, and advancing the data development for the route. Tasks scheduled to be finalized in FEL include:

- Further development of the route data input parameters required for the project approach that will implement this design methodology, including the analysis of the geothermal conditions and the structural analysis – this is a continuing process throughout all phase of the Project
- Further route verification of the data using thermistor readings and other physical testing and data acquisition.
- The terrain units along the identified alignment have been identified and captured in the Project geographic information system (GIS) – appropriate geotechnical parameters identified as required input for the methodology have been assigned to the terrain units based on borehole data. This will be further developed as identified needs progress and/or additional data acquisition enhances the already formidable database.
- The alignment route geo-database has been implemented within the Project GIS, concentrating on the subsurface information available along the routes from past exploratory tasks. Again, this is a continuing process.
- Gaps in the route geo-database will be identified for required site specific exploration.
- Potential manufacturers of the line pipe are contacted, and joints of the line pipe acquired for additional testing to be completed before the end of FEL.

Detailed design will include finalizing the capacity and demand-capacity application evaluation process for the route including the following tasks:

- Finalization of the time-dependent hazard design approach methodology.
- The line pipe strain capacity is determined using the small-scale test results, empirical relations, and verified with full-scale testing.
- The route geo-database will be queried using the design methodology with route segments displaying potential unallowable displacement potential subjected to additional scrutiny and/or mitigative measures.
- The final material and pipe order will incorporate any requirements to implement these measures.

The identified potential line segments subject to additional scrutiny identified in final design may require special mitigative measures that could be the basis of a special construction team. Baseline monitoring will be required within a practicable time after startup, followed with operational monitoring throughout the life of the project. Design reviews by PHMSA and other agencies will occur through the various phases of the project.

Figure 3. Design Approach Flowchart

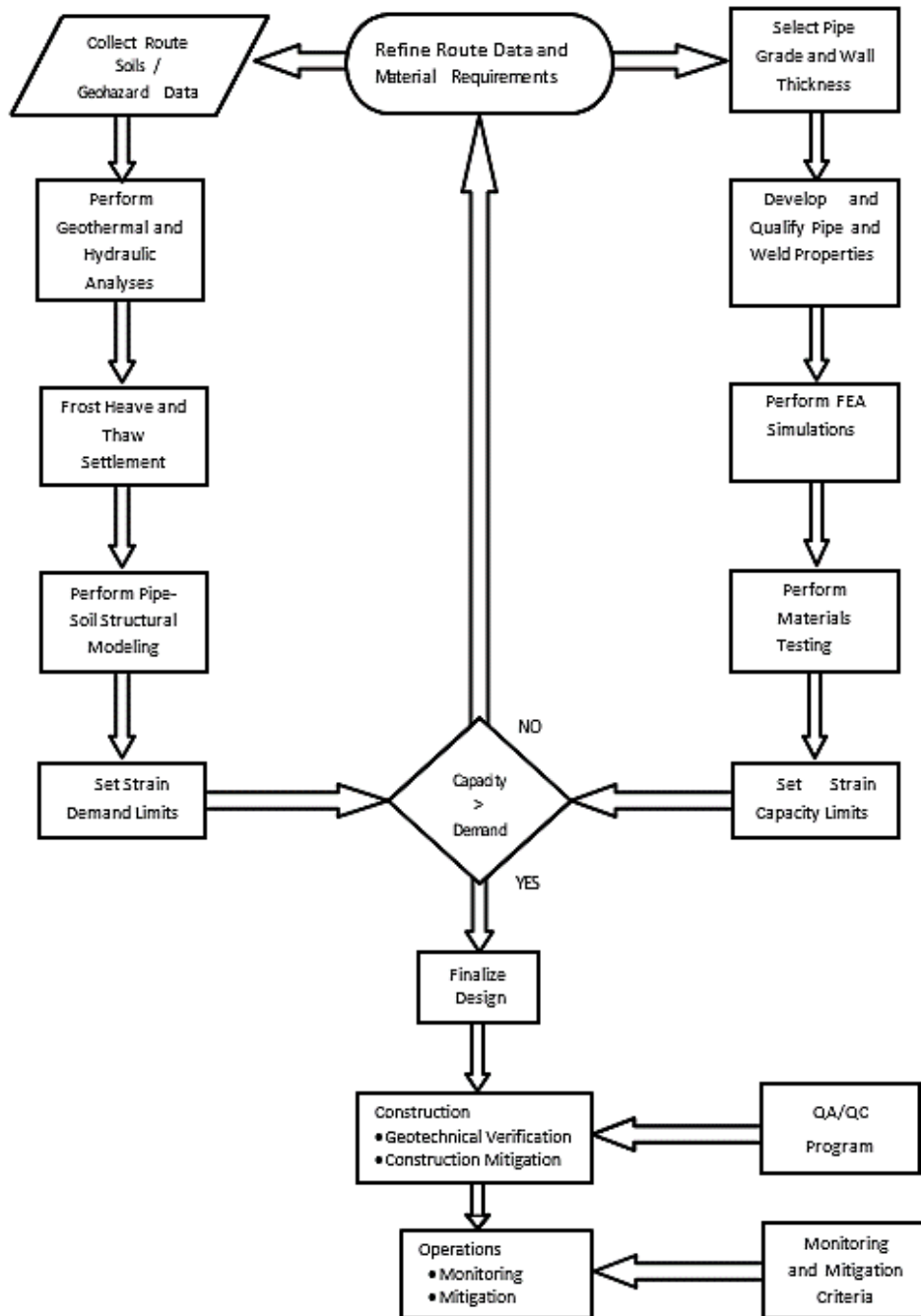

### 1.3 ORGANIZATION OF THE REPORT

Sections 1 through 5 introduce the ASAP design terminology as it applies to this effort. In particular, these chapters relate the development of the methodology that employs strain limits to ensure pipeline structural integrity for those displacement-controlled loadings that induce transverse bending. The introductory material includes background on the determination of the loading, the geothermal analytical methodology used to evaluate the loading, its associated soil and pipe resisting functions, and how these are integrated in a combined pipe-soil interaction analysis. The analytical process measures the effect of the loading and soil resisting functions on pipe response against quantitative structural integrity criteria for the range of route soils to be encountered as well as a range of operational conditions. This evaluation process for the range of alignment conditions forms the demand evaluation, i.e. the ‘demand’ for structural capacity to resist this imposed displacement load. This ‘demand’ is measured against the available ‘capacity’ of the pipe to resist this demand. When the measurement metric is the strain developed in the linepipe, these are appropriately termed strain demand and strain capacity. These concepts are the basis of the approach termed Strain Based Design (SBD).

Section 6 focuses on the line pipe material and fabrication, and the corresponding development of appropriate design limits using these materials. These limits are the linepipe resistance capacity and are used to judge the acceptance or rejection of the demand developed in the previous chapters. Section 6 then addresses the questions:

- How are the strain capacity limits to be developed?
- What tests will be conducted to verify the limits?
- What material requirements will be imposed?

Section 7 outlines the application of the design methodology to the alignment. This includes an introduction to the alignment conditions where the loadings under consideration in this report, thaw settlement and frost heave, could be expected to occur and those areas where these phenomena are not expected to occur. The application methodology is presented as a progressive exclusion sieve, narrowing down the alignment conditions, and associated alignment geographical segments, where the concern needs more detailed evaluation and potential mitigation. This chapter addresses the questions:

- Where might mitigative measures (e.g., heavier-walled pipe, SBD approach, etc.) be needed?

Section 8 addresses construction requirements relating to anticipation of route hazard mitigation, answering the question:

- What modifications to standard construction techniques will be needed?

Section 9 addresses potential operational mitigative methods if operational monitoring concludes the established limits may be exceeded and pipeline integrity is at risk. This chapter addresses the questions:

- What monitoring will be required during operations to ensure the limits are not exceeded?
- What mitigation measures will be employed should the limits be approached or exceeded?

## 2. GEOHAZARDS OVERVIEW

A geohazard is defined as a naturally occurring or project-induced geological, geotechnical, or hydrological phenomenon that could load the pipeline, causing a pipeline integrity concern, or that could impact the right-of-way (ROW), causing an environmental concern. The principal geohazards of concern for arctic design are frost heave and thaw settlement.

### 2.1 GEOTHERMAL CONSIDERATIONS

Geothermal design considers the coupled effect of soil mechanics and heat transfer principles that drive physical processes that can impact the operational reliability and performance of the pipeline. Examples of these processes are:

- Frost bulb formation;
- Frost heave beneath the pipe;
- Thaw bulb formation; and
- Thaw settlement of the soils supporting the pipe.

The preferred mode for the ASAP is buried and it is anticipated the pipeline will encounter thermal states ranging from continuous permafrost in the north, to discontinuous permafrost in the center, and thawed muskeg, alluvial, lacustrine, glacial moraine, and outwash type soils in the central and southern regions (see Figure 4). These conditions potentially require designs that allow for pipeline deformations caused by frost heave and thaw settlement.

To reduce potential impacts along the northern portion, the gas will be chilled to 30°F before leaving the North Slope Gas Conditioning Plant. As the gas travels southward, the operating temperature will fluctuate based on several factors including time of year and the surrounding ambient ground temperature. The Joule-Thompson effect of the natural gas is muted for the relatively low volume throughput for this line. For this reason, ASAP refers to the pipeline as an ‘ambient’ pipeline, indicating the gas temperature will reflect the subsurface thermal conditions.

As indicated in Figure 4, permafrost is typically continuous or discontinuous until the south flank of Alaska Range. For the remainder of the alignment to the pipeline terminus, the permafrost is mapped as sporadic or isolated and the pipeline will be buried in glacially derived landforms that are typically frost susceptible.

Frost heave occurs where unfrozen frost-susceptible soils exist in combination with other critical conditions such as available water and a heat sink. Frost heave mitigation may involve removing/replacing frost-susceptible soils within the influence zone of the pipeline or providing insulation or heat to prevent the frost-susceptible soils below the pipe from freezing. Thaw settlement occurs where frozen thaw-susceptible soils exist in combination with a heat source. In the case of thaw settlement, the heat source could be a change in the surface energy balance (SEB) – this will be described in more detail in Section 3.

With chilling of the gas on the North Slope, it is anticipated the pipeline will operate below freezing for most or all of the year in the continuous permafrost regime. As a result, frost heave is unlikely. Due mostly to construction disturbance, there is a potential for thaw settlement to occur in frozen, ice-rich soils where the pipeline operating temperature is above freezing. This hazard is a focus of concern in the discontinuous permafrost regime.

Figure 4. Permafrost Characteristics

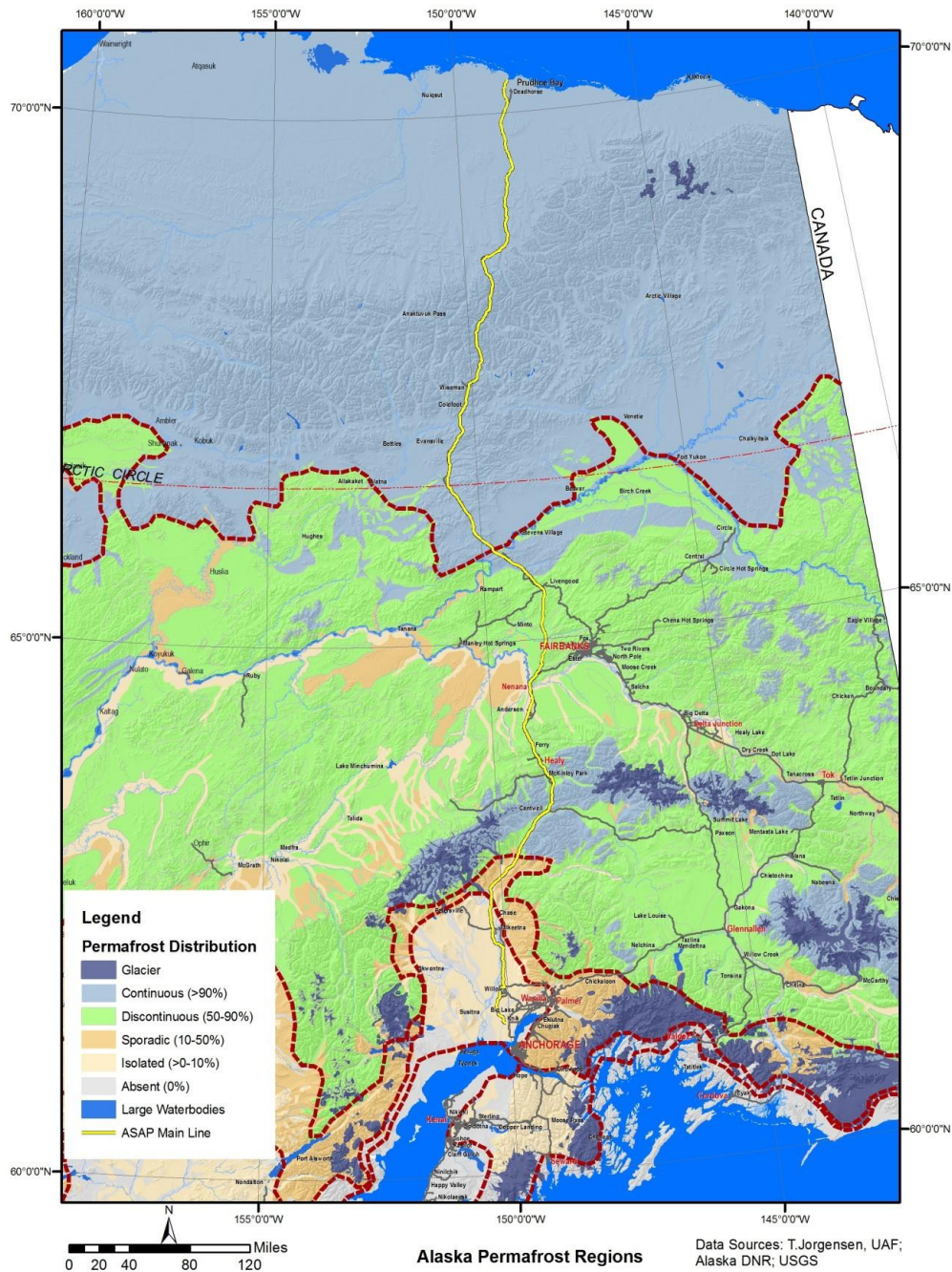

## 2.2 DESIGN DEVELOPMENT

### 2.2.1 Geotechnical data

Geotechnical/geothermal data is used for general and specific geotechnical analysis for the gas pipeline. The following data have been gathered and available to the project:

- Soils, thermal state, and groundwater data from historical borehole and from test pit logs drilled by the project (Tanana River at Nenana), Alaska Department of Transportation and Public Facilities (ADOT&PF), Alaska Rural Rehabilitation Corporation, the University of Alaska Fairbanks (UAF) Water and Environmental Research Center, and the UAF Geophysical Institute.
- Laboratory data from index property and engineering property tests done on borehole and field samples acquired by the Project, ADOT&PF and TAPS.
- General and specific geological and geotechnical data from published sources including the State of Alaska Division of Geological and Geophysical Surveys (DGGs) and U.S. Geological Survey (USGS).
- Orthoimagery and other aerial or satellite based imagery acquired for the project or available from DGGs LiDAR survey.
- Topographic data from project field survey work, aerial photography, and published maps.
- Bedrock data from borehole logs, laboratory testing of samples, field reconnaissance, and available public sources such as ADOT&PF, DGGs, and USGS.
- Terrain unit and landform data developed by the project and from published maps and reports.
- General reconnaissance data from field programs.

### 2.2.2 Geotechnical and Geothermal Parameters for Design

Many design parameters are site specific and will be obtained over time as field studies from the various disciplines are completed. Additional guidelines and the basic approach to geotechnical and geothermal analyses are discussed below.

Geotechnical parameters necessary for analysis and design will initially be estimated based on terrain unit analyses already completed and calibrated against legacy borehole and lab test data recovered for the project. This approach will be augmented by field and laboratory test results from geotechnical investigations.

Thaw settlement is primarily a function of the soil type and water content. The thaw consolidation resulting from thaw of initially frozen materials is a relatively mature subject, having been successfully deployed for the TAPS.

Frost susceptibility is primarily a function of soil grain size where non-plastic fines (typically silt) create pore spaces that facilitate capillarity and freezing point depression. The U.S. Army Corps of Engineers (USACE) frost design and classification system is a universal standard for addressing frost heave behavior (Table 1). Critical conditions for pipeline frost heave distress occur where the

pipeline traverses abrupt contrasts in soil conditions and the soils freeze and thaw repeatedly (seasonally).

Note the frost classification system is based primarily on soil particle size distribution. Geotechnical tests to properly classify and analyze frost heave potential include the tests shown in Table 2 and Table 3 with corresponding standard test methods.

**Table 1. USACE Frost Design Soil Classification System**

Frost Susceptibility <sup>a</sup>	Frost Group	Note	Kind of soil	Amount finer than 0.02mm (wt%)	Typical soil type under USCS <sup>b</sup>
Negligible to low	NFSc	a	Gravels	0 to 1.5	GW, GP
		b	Sands	0 to 3	SW, SP
Possible	PFSd	a	Gravels	1.5 to 3	GW, GP
		b	Sands	3 to 10	SW, SP
Low to medium	S1		Gravels	3 to 6	GW, GP, GW-GM, GP-GM
Very low to high	S2		Sands	3 to 6	SW, SP, SW-SM, SP-SM
Very low to high	F1		Gravels	6 to 10	GM, GW-GM, GP-GM
Medium to high	F2	a	Gravels	10 to 20	GM, GM-GC, GW-GM, GP-GM
Very low to very high		b	Sands	6 to 15	SM, SW-SM, SP-SM
Medium to high	F3	a	Gravels	>20	GM, GC
Low to high		b	Sands except very fine silty sands	>15	SM, SC
Very low to very high		c	Clays, Ip>12	-	CL, CH
Low to very high	F4	a	All silts	-	ML, MH
Very low to high		b	Very fine silty sands	>15	SM
Low to very high		c	Clays, Ip>12	-	CL, CL-ML
Very low to very high			Varved clays and other fine-grained banded sediments	-	CL and ML; CL, ML, and SM; CL, CH, and ML; CL, CH, ML, and SM

<sup>a</sup> Based on laboratory frost-heave tests

<sup>b</sup> G, gravel; S, sand; M, silt; W, well graded; P, poorly graded; H, high plasticity; L, low plasticity

<sup>c</sup> Non-frost susceptible

<sup>d</sup> Requires laboratory frost-heave test to determine frost susceptibility Source: Johnson et. al. 1986

**Table 2. Geotechnical Tests for Frost Heave Potential**

Test	Standard
Moisture content	ASTM D2216
Gradation (sieve analysis)	ASTM C136
Gradation (sieve with hydrometer)	ASTM D422
Atterberg Limits	ASTM D4318
ASTM = American Standard Testing Materials	

**Table 3. Additional Geotechnical Tests for Frost Heave Evaluation**

Test	Standard
Moisture-Density Relationship	ASTM D1557
Specific Gravity	ASTM C127
Unit Weight of Frozen Soil	Gravimetric test of undisturbed frozen soil

Additional geotechnical parameters needed to forecast frost heave include permeability; pressure on the freezing front; frost penetration rate and frost heaving rate; longitudinal, bearing and uplift resistance; soil load/deflection and creep characteristics; soil temperature gradient, and climatic data. Many of these parameters can be empirically correlated with the results of geotechnical tests listed above. A probabilistic approach to assigning soil properties is adopted where sufficient sample data is acquired by the project. When data gaps are identified, they will be filled as necessary. Climatic data described in Section 3 is updated to include most recent data from stations along the route. Limits of applicability of climatic data will be based on geographic similarities along the line.

The approach to time dependent geohazard analysis will be to combine route soils data with climatic data and subsurface thermal predictions and pipe deformation analysis. Thermal conditions of the pipeline and ground will be predicted using a coupled hydraulics/geothermal model, i.e. this model will be comprised of a linear hydraulics model of the pipeline with two-dimensional ‘slices’ of soil defined at intervals along the pipeline. The slices are defined principally by the terrain unit analysis, thus geotechnical information will accompany each slice that allows prediction of subsurface thermal changes. The hydraulics model will predict temperatures along the pipeline for a given throughput, inlet temperature and pressure, initial soil temperatures, and gas properties. The pressure and temperature of the flowing gas depends upon the heat flux through the pipe wall which, in turn, depends on the pipe interaction with the subsurface thermal state (ground temperatures). As noted earlier, hydraulic analyses to date on the current ASAP Project configuration indicates the pipe reflects the route subsurface conditions and has relatively small effect on changing these conditions from the influence of other inputs (e.g. surface changes). This is due to the relatively low throughput volume of the pipeline.

Predictions of the ground temperatures surrounding the pipe will be made by the geothermal model. The model will consider a two-dimensional ‘slice’ of the pipe surrounded by soil regions and bounded on the surface by location dependent varying climatic functions. A finite element approach will be applied to develop a series of ‘snapshots’ along the pipeline of the changing thermal condition of the subsurface over time, which is in turn is used to estimate the heat flux along the alignment to the flowing gas. The result is an estimate of the magnitude and timing of the subsurface thermal conditions including the geometry of the evolving thaw/frost bulb. This same process is used to evaluate both frost and thaw potential.

The pipe/soil thermal regime and geotechnical properties that define the soil’s frost/thaw susceptibility will then be used to predict the amount of heave/thaw consolidation beneath the pipeline.

The predictions are calibrated against results of previous laboratory and field testing and observation performed by the research community and special testing completed by industry for other projects.

### 2.2.3 Application of Methodology

Similar to the data describing the pipe material properties and the associated functional behavioral description, the geotechnical properties are also integrated in the pipe-soil interaction analysis within the program PIPLIN (SSD Inc. pipeline analysis software), described in Section 5 of this report. These geotechnical properties describe two parts of the soil interaction analysis: the displacement imposed on the pipe ditch bottom over time (i.e., the restrained heave or thaw consolidation), and the resistance to the pipe movement by the soils surrounding the buried pipe. As described in Section 5, the pipe strain demand resulting from the predicted ditch displacement is determined through a series of pipe-soil interaction analyses that consider the displacement of the soils beneath the pipe and the resistance of the soil to this differential pipe movement.

Problematic areas identified in performing this route-wide analysis will be subject to site-specific analysis. The site-specific analysis will follow the same general approach, but will utilize more refined soil and thermal inputs. If the site-specific analysis results in unacceptable levels of pipe strain demand (i.e., pipe strain demand that exceeds the pipe strain capacity), then mitigative measures would be employed as appropriate.

### 3. GEOTHERMAL METHODOLOGY

#### 3.1 GEOTHERMAL ANALYSIS OVERVIEW

Seasonal temperature changes at the ground surface result in continually varying ground temperatures. Installation of engineered thermal components such as pipelines, superimpose additional temperature variations. Geothermal analysis employs numerical modeling of heat transfer to determine temperature variations both spatially within the soil, and temporally through time.

Geothermal analysis accounts for several important variables affecting soil temperatures including, soil material properties (such as thermal conductivity, soil moisture content, and latent heat), thermal boundary conditions (such as energy exchange at the ground surface and heat transfer between the operating pipe and the surrounding soil), and phase change and the associated latent heat of soil moisture.

In the context of route geohazards, geothermal analysis is used to determine long-term thaw depths both below the disturbed ROW and below the pipe, and to simulate pipeline frost heave caused by the development of a frost bulb in areas where a chilled pipeline intersects unfrozen soils.

#### 3.2 MODELING SUBSURFACE GEOTHERMAL CONDITIONS

Modeling subsurface geothermal conditions requires establishment of an overall geothermal modeling approach, definition of the domain geometry, assembly of several material properties and boundary conditions, and proper model calibration. These aspects of geothermal modeling analysis are discussed in the following sections.

##### 3.2.1 General Modeling Approach

Geothermal modeling is typically undertaken to answer specific questions that arise as a result of an engineering design and/or a change to thermal conditions such as construction disturbance or climate warming. Once the main objective of a geothermal analysis is established, it is necessary to undertake the modeling effort with an approach that will meet the specified objectives. Typically, the following general approach is used:

- Establish the domain geometry
- Define soil material properties
- Specify initial temperature conditions
- Define thermal boundary conditions
- Determine maximum simulation time.
- Calibrate the geothermal model to reproduce existing undisturbed conditions then apply variation to boundary conditions to simulate effects of construction and/or operations.
- Interpret results and report findings.

The Project approach to the development of each of these items is discussed in the following sections.

### 3.2.2 Domain Geometry

Establishing the domain geometry entails defining the dimensionality of the analysis (one-, two- or three-dimensional) and establishing the overall geometry of the analysis such as the soil layering, modifications to undisturbed soil layers such as organics removal, and for pipeline analyses, specification of the pipe diameter, pipe cover depth and trench dimensions.

Once the domain geometry is defined, it is typically discretized into a finite element mesh, an example of which is shown in Figure 5. A more detailed view of the model in the immediate vicinity of the pipe is shown in Figure 6. The modeling domain shown in the figures includes an organic soil layer overlying mineral soil along with a buried pipeline. The purple surface soil layer represents the compressed organic layer over the width of the ROW, and the undisturbed surface organic layer is indicated by green. The red and green circles on the ground surface represent the differing ground surface boundary conditions on and off the ROW, respectively. Light blue circles on the perimeter of the pipeline represent the pipe temperature boundary conditions.

**Figure 5. Geothermal Model Domain and Finite Element Mesh**

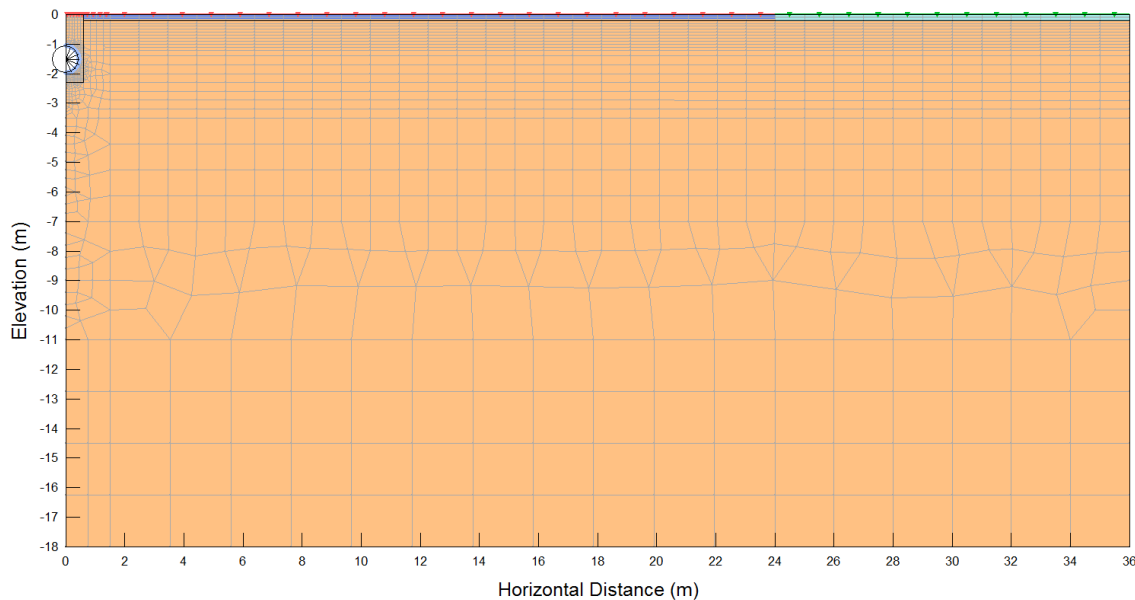
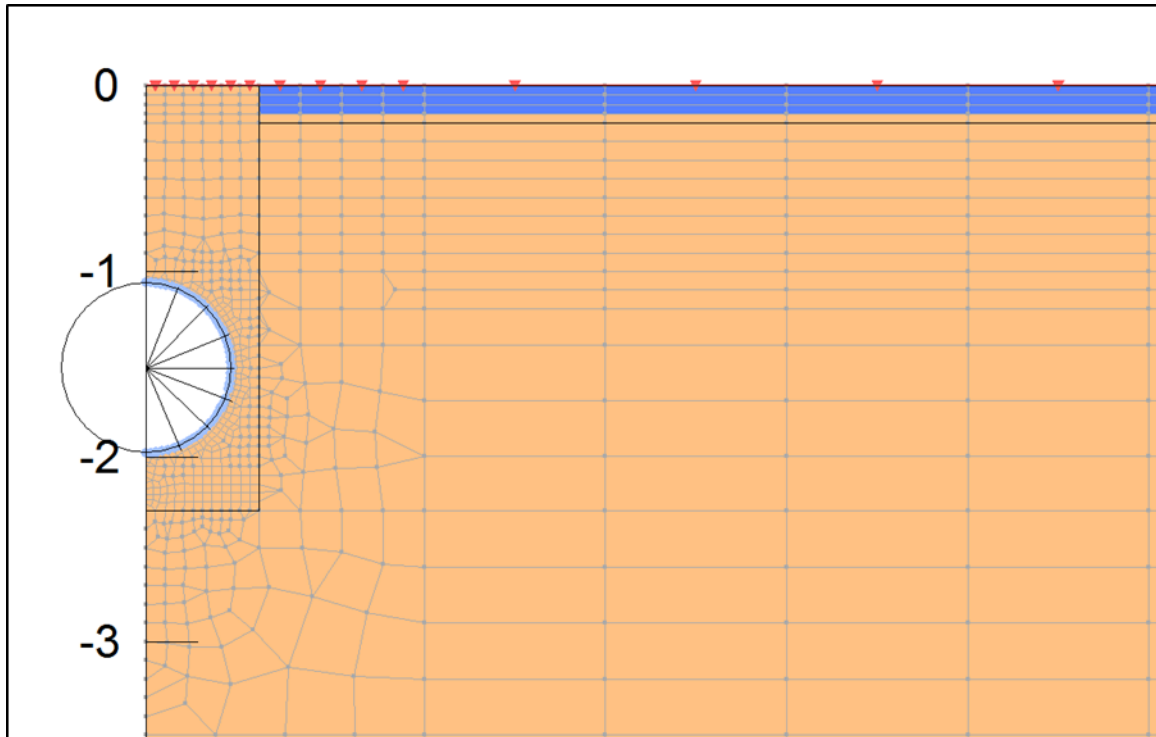

Figure 6. Geothermal Model in the Near Vicinity of the Pipe



### 3.2.3 Soil Properties

For each soil in the geothermal model it is necessary to specify the soil type and key soil index properties such as moisture content, dry density, and water saturation ratio. From these soil index properties it is possible to determine soil thermal properties such as thermal conductivity, heat capacity and latent heat content using published relationships between soil index properties and thermal properties.

The soil properties used in the geothermal model domain presented in Figure 5 are presented in Table 4.

**Table 4. Soil Index and Thermal Properties**

Parameter	Sat. Silt & Clay Soil w=35%	Sat. Silt & Clay Soil w=25%	Organic Soil w=200%	Compressed Organic Soil w=150%	Unit	Description
Gs	2.67	2.67	1.4	1.4	-	specific gravity of solids
n	0.48	0.40	0.76	0.70	m <sup>3</sup> /m <sup>3</sup>	porosity
S	1.00	1.00	0.90	0.90	m <sup>3</sup> /m <sup>3</sup>	saturation
w	0.35	0.25	2.04	1.50	g/g	gravimetric water content
A	0.100	0.100	0.050	0.050	-	unfrozen water content at -1 C
B	-0.300	-0.300	-0.700	-0.700	-	unfrozen water content function exponent
Ku	1.20	1.40	0.40	0.43	J/(s*m*C)	unfrozen thermal conductivity of soil
Kf	2.00	2.00	0.90	0.87	J/(s*m*C)	frozen thermal conductivity of soil
L	3.34E+08	3.34E+08	3.34E+08	3.34E+08	J/m <sup>3</sup>	latent heat of water
Cw	4.187E+06	4.187E+06	4.19E+06	4.187E+06	J/(m <sup>3</sup> *C)	heat capacity of water
Ss	0.17	0.17	0.4	0.4	-	specific heat capacity of solids (organics 0.40 , mineral soil 0.17)
Cu/Cw	0.696	0.651	0.828	0.741	-	unfrozen heat capacity of soil relative to water
Cf/Cw	0.463	0.457	0.482	0.449	-	frozen heat capacity of soil relative to water
pdry	1350	1550	340	390	kg/m <sup>3</sup>	dry density of soil
pwat	1000	1000	1000	1000	kg/m <sup>3</sup>	density of water
theta	0.48	0.40	0.68	0.63	-	volumetric water content of soil
Ku	103.7	121.0	34.6	37.2	kJ/(d*m*C)	unfrozen thermal conductivity
Kf	172.8	172.8	77.8	75.2	kJ/(d*m*C)	frozen thermal conductivity
Cu	2915	2724	3467	3103	kJ/(m <sup>3</sup> *C)	unfrozen heat capacity
Cf	1938	1913	2018	1878	kJ/(m <sup>3</sup> *C)	frozen heat capacity
L	3.34E+05	3.34E+05	3.34E+05	3.34E+05	kJ/m <sup>3</sup>	latent heat of water

Cf = cubic feet

### 3.2.4 Initial Conditions

In undisturbed terrain, the mean annual ground temperature (MAGT) is governed as a sum of energy fluxes as discussed later. To establish a calibrated geothermal model (also discussed later), it is vital to have either a measured or estimated value for the MAGT at the location to which the geothermal model applies. Therefore, MAGT is the most important initial condition parameter to specify for geothermal modeling.

### 3.2.5 Ground Surface Boundary Condition

For modeling the ground surface boundary condition two main approaches are used, namely, n-factors or a SEB model. With the n-factor approach the ground surface temperature is directly specified in the geothermal model by multiplying the n-factor by the air temperature. Two n-factors are required, a freezing n-factor for winter and a thawing n-factor for summer.

With the SEB approach, heat energy flux components and the net heat energy flux at the ground surface are calculated and specified as a spatially variable (i.e. can vary across the ground surface)

energy flux boundary condition at the ground surface in the geothermal model. As a result, the ground surface temperatures are calculated by the geothermal model, and are not pre-specified as model input as is done when n-factors are used.

The SEB approach requires ground surface properties of evapotranspiration factor, summer and winter albedo (surface reflectivity), and snow thermal conductivity. Although winter albedo (snow reflectivity) data is readily available, at northern latitudes winter albedo is an insensitive model input parameter because there is relatively little daylight (solar radiation) during winter. Values for summer albedo and evapotranspiration factor depend on ground cover type (such as forested, grass, tundra, gravel) and are also readily available in published literature. As discussed later, reasonable uncertainties in the ground surface properties and climate data are not problematic when using an SEB model because a properly calibrated geothermal model using a ground SEB boundary condition is characteristically equifinal because the effects of uncertainty errors in some input parameters are essentially self-corrected by other ground surface energy flux components.

Soil temperatures are very sensitive to snow thermal conductivity. Snow cover acts as an insulative blanket in winter and limits the heat transfer from the relatively warm ground. The sensitivity of snow thermal conductivity is accounted for during calibration of a geothermal model. The model is calibrated by varying the snow thermal conductivity until the model computed MAGT matches the measured or target MAGT at the location of interest. The snow thermal conductivity in the model as determined by model calibration represents the average snow thermal conductivity over the course of multiple winters of the geothermal simulation.

### 3.2.6 Climate Data

Mean monthly air temperature data are a minimum requirement for any geothermal analysis at a particular location. An SEB model at the ground surface also requires mean monthly values for snow depth, wind speed and solar radiation. Climate normals data are typically available online from government sources.

### 3.2.7 Pipe Temperature Boundary Condition

The pipe temperature boundary condition is typically determined by pipeline hydraulics analysis. For arctic pipelines, a more sophisticated thermal-hydraulics analysis is often necessary. A thermal-hydraulics analysis couples steady-state pipeline hydraulics with geothermal analysis in the soil to determine the heat transfer between the pipeline and the surrounding soils, and to determine pipe temperatures and pressures along the pipeline required for pipeline design.

Pipe temperatures determined from a pipeline hydraulics analysis are used to define the pipe temperature boundary conditions on specific geothermal models undertaken to assess location-specific issues such as thaw depth, frost heave, or water crossings for pipeline design. Typically, mean monthly pipe temperatures are necessary from the hydraulics model for input to geothermal analysis. Pipe temperatures for any point in time are interpolated from the mean monthly pipe temperature data.

### 3.2.8 Periodic Steady-State

Thermal steady-state refers to a condition where temperatures reach constant values and do not change with time. Soils within the top 20 to 25 feet from ground surface never experience thermal steady-state because of continuous temperature change caused by seasonal temperature variations

at the ground surface. However, if the varying temperature boundary conditions repeat identically year after year, then the temperatures in the soil, after nominally 5 to 10 years, will reach what is called periodic steady-state.

Conditions of periodic steady-state are characterized by identical temperature variation each year. The concept of periodic steady-state is important to understand because it is fundamental when calibrating a geothermal model to undisturbed conditions. In addition, some modeling scenarios may reach periodic steady-state, whereas others, such as long-term thaw in warm permafrost caused by surface disturbance, may not reach periodic steady-state within typical pipeline design lifetimes on the order of 30 years. Model calibration is discussed further later.

### 3.3 RELATIONSHIP BETWEEN CLIMATE AND THE SURFACE AND SUBSURFACE CONDITIONS

The long-term MAGT is governed by the local climate and in particular, by the exchange of heat energy between the ground and the above-ground environment. Energy flux components of most importance include solar radiation (shortwave radiation from sunlight), longwave radiation continually emitted from the ground or snow surface, convective heat transfer with the atmosphere, and evapotranspiration (evaporation of surface water and transpiration of water from plants).

A SEB models for modeling energy fluxes at the ground surface are based on the concept of summing these flux components to determine the net energy flux at the ground surface (Hwang, 1976). This is represented mathematically with the equation:

$$Q_G = Q_S + Q_L + Q_C + Q_E$$

Where:

- $Q_G$  = net flux across the ground surface
- $Q_S$  = solar radiation flux
- $Q_L$  = longwave radiation flux
- $Q_C$  = convective heat flux between ground and air
- $Q_E$  = evapotranspiration flux

Each of the energy flux components shown above has units of energy rate per unit area of ground surface (for example,  $W/m^2$ ). Each flux component contributes energy influx, energy outflux, or both, to the net energy flux across the ground surface. Specifically, solar radiation is an energy influx to the ground surface; longwave radiation is an energy outflux component; evapotranspiration is an energy outflux component; and convective heat transfer can be either an energy influx or outflux component depending on the air temperature being warmer or colder than the ground/snow surface.

Each of these energy flux components is either directly specified as input to the SEB model, or is computed based on ground/snow surface temperatures and climate data. Solar radiation is the sim-

plest flux component as it is a directly specified climate data input. Longwave radiation is calculated using ground/snow temperature and requires no additional climate data. Convective heat transfer between the ground/soil surface and the atmosphere is calculated using air temperature and wind speed climate data. Finally, evapotranspiration is calculated using air temperature data and hours of daylight at the location latitude. Snow depth climate data, although not used to calculate any of the energy flux components, acts as a thermal insulation layer in winter, and is included in geothermal modeling. Details regarding the SEB calculations are available in (Matrix 2013).

For each of the climate data sets, mean monthly values are sufficient to specify variations through time. Typically, the annual normal climate is repeated year after year in the geothermal model. To model climate change, it is necessary to model variations or continual trends from year to year. Higher frequency variations, such as diurnal (daily) variations in solar radiation, temperature and wind speed need not be considered because such variations damp out quickly with depth below ground surface (bgs) – nominally 0.2 meters (8 inches) bgs.

It is also noteworthy the SEB modeling exhibits equifinal behavior when used with a calibrated geothermal model. Equifinality means the SEB model is not particularly sensitive to uncertainty errors in the SEB model input data because of the self-corrective, or counter-balancing, effect of some energy flux components on other energy flux components. For example, if a solar radiation energy influx was incorrectly specified as too high, this would by itself cause an increase of ground surface temperature. However, a higher ground surface temperature results in higher computed outfluxes from longwave radiation, convective heat transfer with the atmosphere, and from evapotranspiration. These three outflux components would counteract the ground temperature increase caused by the erroneously high solar radiation input value. Experience with application of SEB modeling for the ground surface boundary condition in geothermal modeling has shown that equifinality renders SEB as a robust technique that is useful for simulating changes of conditions at the ground surface and changes with climate, in particular because SEB is relatively insensitive to reasonable uncertainty errors in the input data.

Using SEB in geothermal modeling has been compared with measured results in the field (Matrix 2015). A comparison of measured ground surface net flux made near a flux tower at a University of Alaska research site near the Fairbanks surface disturbance (FSD) test site (Nakai 2013) and the model-computed net flux is shown in Figure 7. The flux tower data was collected as part of an investigation into evapotranspiration from black spruce forests, the dominant vegetation in the region, and is the best data available in the region for measured surface fluxes. Although the model-computed net energy flux at ground surface does not exactly match the measured flux, the correspondence is remarkably good in the winter months and reasonably good in summer, especially when it is considered the flux measurements are for a single year and the model is based on long-term climate normals.

Each of the model-computed ground surface energy flux components are presented in Figure 8. A positive energy flux denotes the addition of energy into the ground. The rapid change in the model-computed fluxes shown in Figure 7 and Figure 8 in early May corresponds to the disappearance of snow cover. A similar, albeit less dramatic change in fluxes occurs in the fall when the

snow cover returns. Upon the disappearance of snow cover, solar radiation on the darker ground surface results in a significant energy input from solar radiation. This energy input is counteracted by increased energy loss from convective heat transfer to the atmosphere. Energy losses via evapotranspiration also occur in summer.

Heat losses from longwave radiation emission occur throughout the year and are greater in summer than in winter. Interestingly, and perhaps initially counterintuitive, the atmosphere does not remove heat from the ground in winter. Instead, ground heat and atmospheric heat is removed solely by longwave radiation emitted from the snow surface. As shown in Figure 9, the snow surface is the heat sink during winter, drawing heat from the ground surface and the air simultaneously. On cold weather days, more heat is extracted from the ground because of the lower rate of heat transfer from the air to the snow surface relative to warm weather days.

**Figure 7. Comparison of Measured and Model-Computed Ground Surface Net-Flux, FSD Test Site, Undisturbed Terrain**

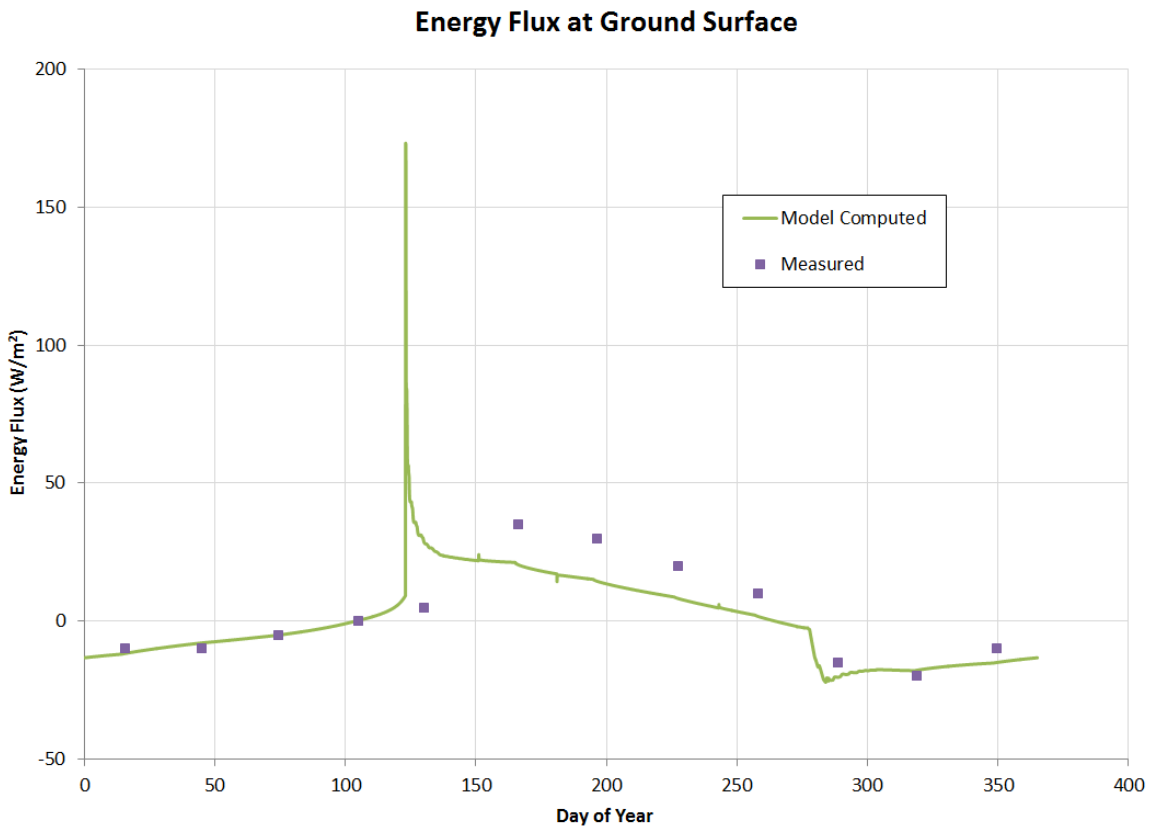
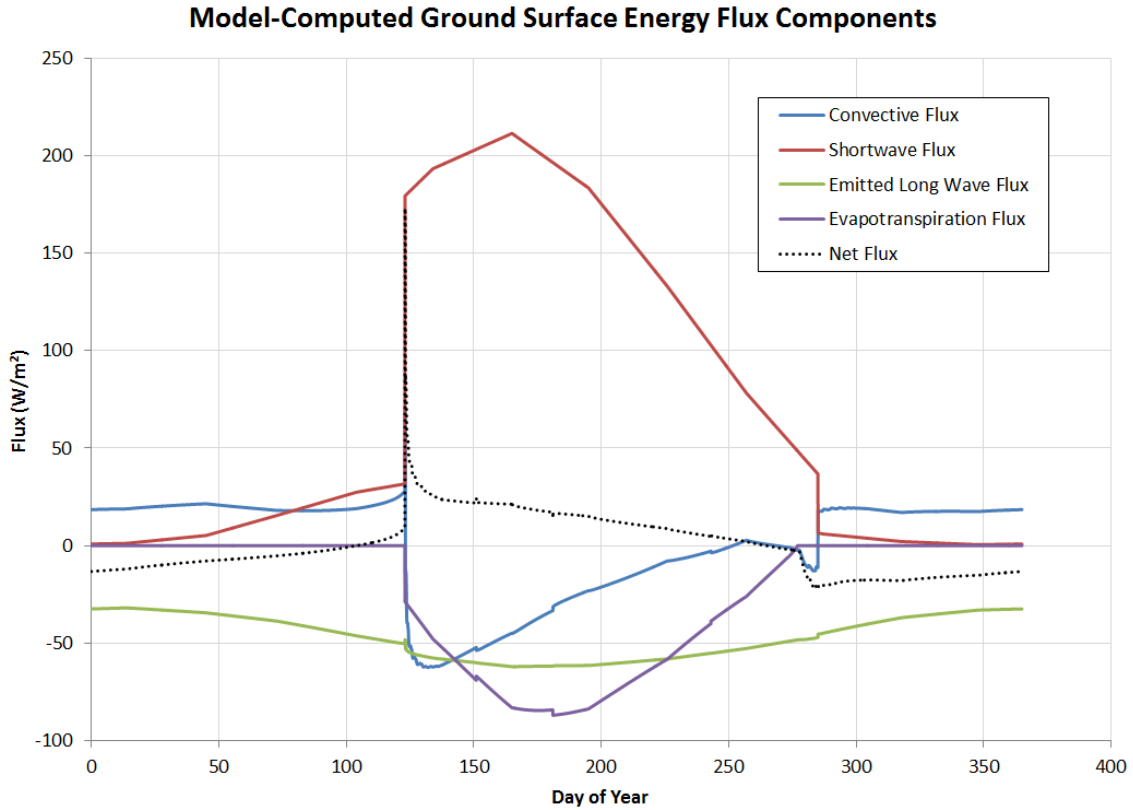
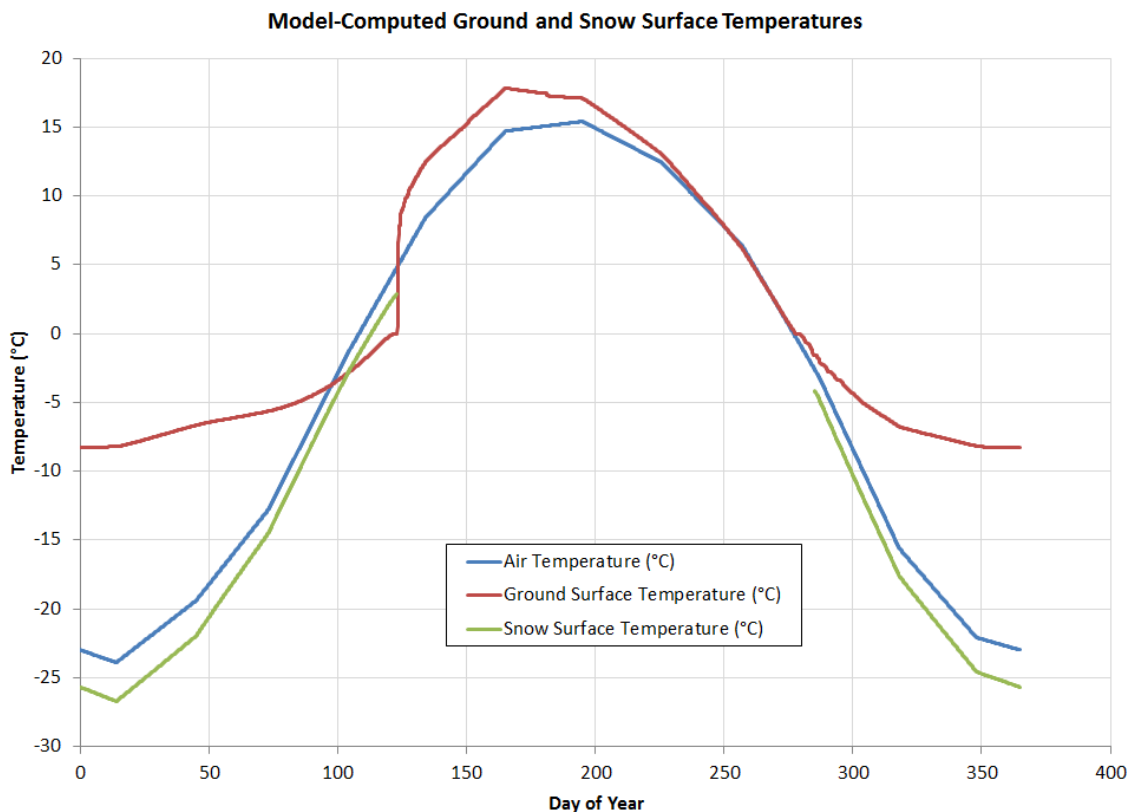

Figure 8. Model-Computed SEB Flux Components, FSD Test Site, Undisturbed Terrain



**Figure 9. Model-Computed Ground and Snow Surface Temperatures, FSD Test Site, Undisturbed Terrain**



In summary, the long-term MAGT is governed by the local climate and in particular by the summation of energy flux components at the ground surface. Energy exchange at the ground surface is modeled using a SEB model (Hwang 1976), and there is ample experience in this regard (such as (Matrix 2013) and (Matrix 2015)). Importantly, an SEB model dynamically computes (spatially and temporally) the net energy flux at the ground surface, which is used as a thermal boundary condition by the geothermal model to compute the ground temperatures, including at the ground surface. Therefore, a key benefit of using SEB is the ground surface temperatures are computed, not specified, as is the case when n-factors are used. SEB modeling requires relatively simple climate data in the form of mean monthly values of air temperature, wind speed, solar radiation and snow cover depth. Another significant benefit of using SEB in a calibrated geothermal model is the SEB-computed net energy flux at the ground surface is relatively insensitive to uncertainty error in the input parameters, and as such exhibits equifinal response.

### 3.4 ROUTE DATA REQUIREMENTS

For geothermal modeling, the following data is required along the pipeline route:

- MAGT versus MP – Measured values of MAGT from borehole thermistor strings is amongst the most valuable data for geothermal modeling. MAGT will vary with latitude, elevation, and with local micro-climate variations along the route. It is required for pipeline hydraulics modeling, and for more location-specific geothermal analyses such as thaw settlement and frost heave.
- Climate data versus MP – Mean monthly values of air temperature, wind speed, solar radiation and snow cover are required. Presuming these data are available only at discrete locations along the route, interpolation may be used for locations between.
- Changes to ground surface properties to simulate construction disturbances such as tree clearing, surface organic layer compression by construction equipment, and gravel pads. For SEB modeling, construction disturbance may be simulated by changes to evapotranspiration and summer albedo values (Matrix 2015). If n-factors are used, then they may be modified to increase ground temperature. In any event, if SEB or n-factors are used, the geothermal model-computed long-term thaw depth should be calibrated against measured long-term thaw depths from results such as the FSD site as discussed below.

### 3.5 MODEL CALIBRATION

#### 3.5.1 Calibration to Mean Annual Ground Temperature

For any geothermal modeling location along a pipeline route, model calibration is necessary to ensure the model calculates the expected MAGT at the location, using the appropriate climate data for that location.

Calibration is typically performed by running a 1D (one-dimensional) geothermal model for undisturbed terrain and adjusting the snow thermal conductivity after each run, essentially iterating, to determine a calibrated snow thermal conductivity. It is necessary to verify the snow thermal conductivity determined by the calibration procedure is within the bounds of measured snow thermal conductivity, which ranges from 0.08 W/m-°C to 0.7 W/m-°C (Andersland and Ladanyi 2004).

After calibration is complete, the model-calculated temperature profile in undisturbed terrain has a MAGT matching the expected MAGT value, and the active layer depth is also checked to ensure that it is within the range of active layer depths representative of the locale.

Figure 10 shows the annual minimum, mean, and maximum temperature profile computed by a geothermal model and is representative of typical conditions in warm permafrost. Seasonal temperature variation is greatest at the ground surface and decreases with depth. Below about 6-meter depth, the annual temperature amplitude is essentially zero. The minimum and maximum temperature data series (shown in blue and red, respectively), outline the so-called ‘trumpet curve.’ The

MAGT with depth is shown in green. It is important to note the minimum and maximum temperature profiles shown do not represent the temperature versus depth at any particular point in time, but instead indicate the minimum and maximum temperatures reached on an annual basis with depth.

Geothermal heat energy continuously flows from the earth’s core and is radiated at the ground surface resulting in a geothermal gradient that is evident in Figure 10 as increasing temperature with depth. The permafrost in this case has a temperature of  $-0.5^{\circ}\text{C}$  and the base of the permafrost is indicated where the temperature profile rises above freezing ( $0^{\circ}\text{C}$ ) at a depth of just over 14 meters in this case. The active layer depth in this case is about 1.2 meters as indicated by the dashed horizontal line in Figure 10. Within the active layer the maximum annual ground temperature (red data series) reaches very warm temperatures at the ground surface, but warm temperatures do not penetrate deep into the ground because of the high latent heat of ice in the permafrost soil.

**Figure 10. Geothermal Model Calibration to Target MAGT**

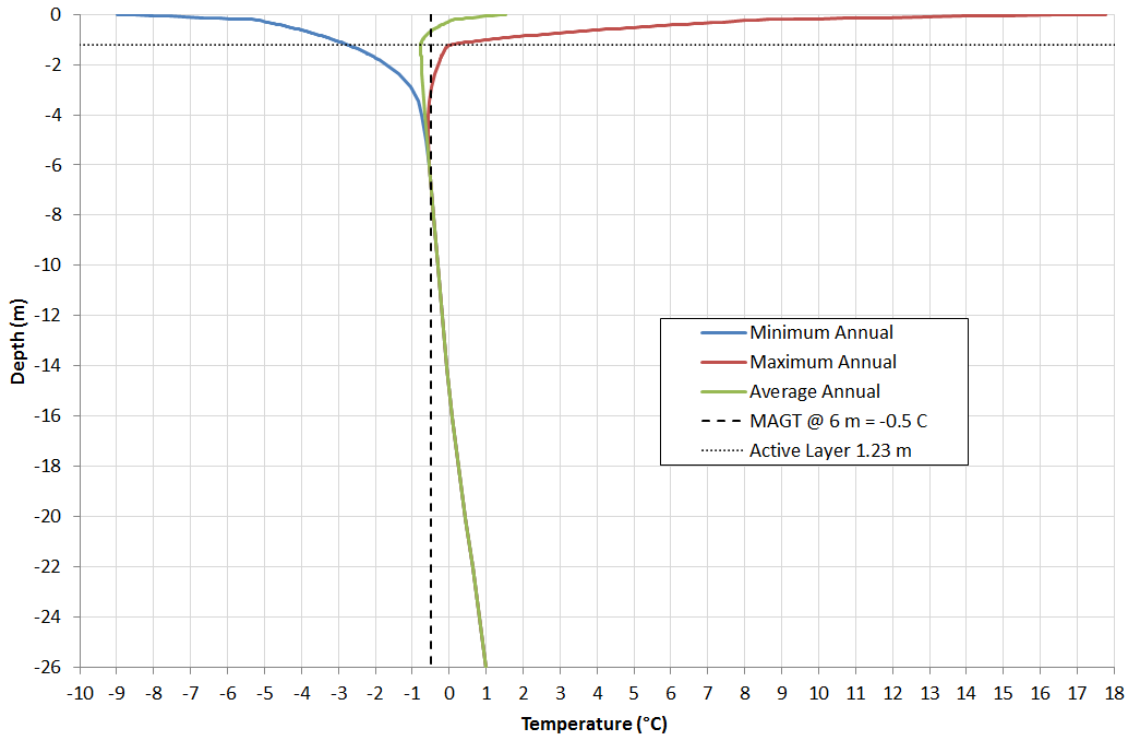

### 3.5.2 Calibration of Long-Term Thaw Depth from Ground Surface Disturbance

During pipeline construction, ground surface disturbance occurs from tree clearing on the pipeline ROW and from compression of the surface organic layer from operation of heavy equipment. The disturbance of the ground surface causes changes to the heat energy fluxes at the ground surface, causing an overall net increase of heat energy into the ground on an annual basis. For example, tree clearing increases the amount of solar radiation reaching the ground surface, and compression of

the surface organic layer increases its thermal conductivity, thus decreasing its insulative effectiveness. In the colder continuous permafrost terrain in northern Alaska, this increase in energy influx to the ground from surface disturbance may simply cause an increase in the active layer depth; however, in the warmer discontinuous permafrost terrain in the mid-latitudes of Alaska, surface disturbance can cause a long-term increase in thaw depth. In the latter case, the maximum winter refreeze depth from the ground surface downward may not reach the thaw front depth which increases year after year. For pipeline design, it is necessary to use geothermal modeling of the disturbed ROW together with pipeline operating temperature conditions to assess long-term thaw settlement of the pipeline. It is important the geothermal model be calibrated such that it will reproduce the long-term thaw depth observations when available.

For geothermal model calibration and validation of long-term thaw depth, the FSD test site was utilized (Matrix 2015). The site is near Fairbanks, Alaska, and is located at 65° N latitude. At the FSD site, three test plots were established in 1946; a plot of undisturbed terrain, a plot where the trees were manually cleared, and a plot where the trees were cleared and the surface organic layer was removed down to mineral soil. These plots are referred to herein as the undisturbed, cleared, and stripped plots, respectively. The cleared and stripped plots were maintained as such from 1946 to 1972 (Linell 1973); (Douglas et al 2008). Each plot was a square area of 200 feet per side.

For the ASAP Project, geothermal modeling was performed using a 1D geothermal thermal model with a SEB model as the ground surface boundary condition (Matrix 2013). The model was calibrated such that the measured MAGT matched the corresponding model-computed values. Ground surface disturbance simulations were then performed using ground surface properties which were modified to simulate tree removal and removal of the surface organic layer for the cleared and stripped terrain cases. The thaw depth time series from these simulations compared well with the thaw depths observed at the FSD site as shown in Figure 11 (reproduced from Matrix 2015). More details regarding geothermal model calibration to observed long-term thaw depths is provided in (Matrix 2015).

Figure 11. Geothermal Model Surface Disturbance Calibration

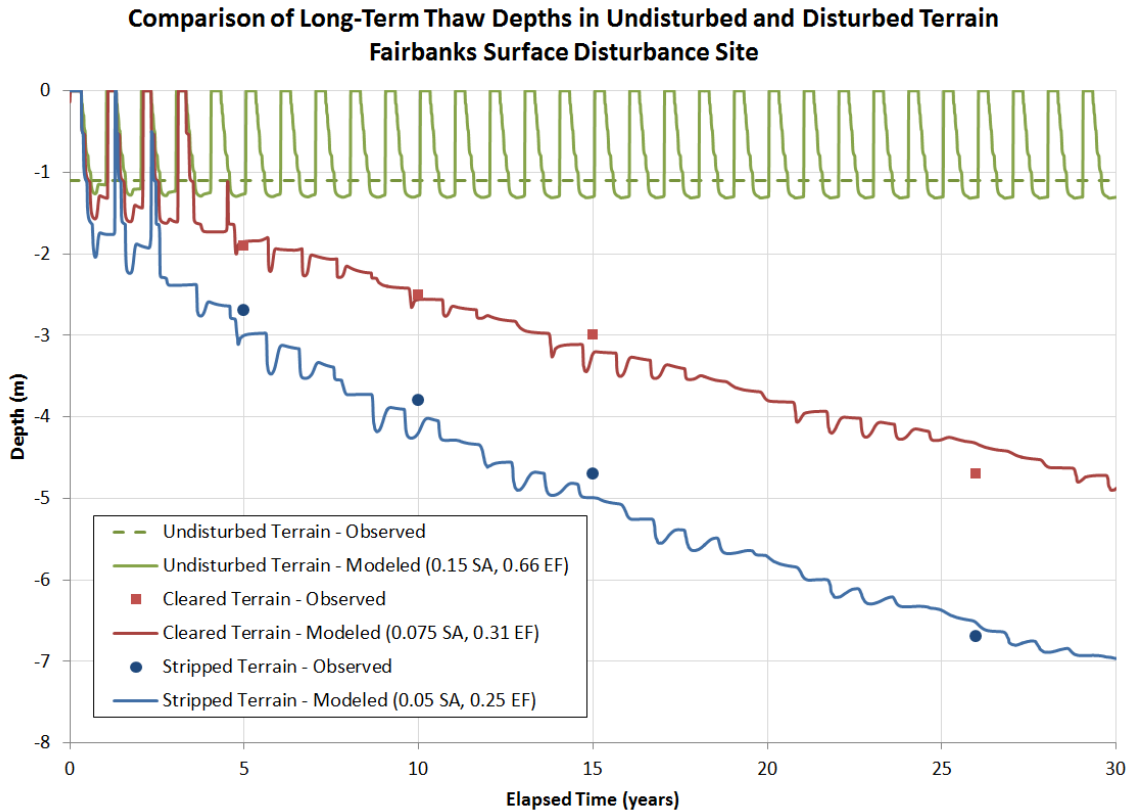

### 3.6 SAMPLE RESULTS

An analysis was run for the ASAP ROW in the Fairbanks area. This sample was based on a worst-case scenario of the ROW with a gravel pad on warm permafrost containing fine grain material and a high moisture content. The analysis was allowed to revegetate to a ‘cleared’ state, meaning grasses and small plants, but no trees for 53 feet, (25 feet on each side of the pipe, plus the pipe diameter of 3 feet), outside the 53 feet, the construction ROW was allowed to revegetate to a treed condition gradually over 20 years. The analysis was run over a 30-year time frame. The analysis indicates that for the input conditions with the gravel workpad, the thaw zone is about 105 feet at the ground surface from pipe centerline on the workpad side of the pipe, and about 73 feet at the ground surface from pipe centerline on the spoils side of the pipe. This equates to a thaw zone over 30 years of about 178 feet end to end at the ground surface lateral to the pipe and 22 feet at the deepest point below the ground surface, based on this model. Complete results are found in Appendix B.

## 4. STRUCTURAL MECHANICS OF BURIED PIPELINES

Although some sections of the ASAP are aboveground, notably at waterway and fault crossings, ASAP is primarily a buried pipeline. Buried pipelines are essentially ‘restrained,’ that is, displacement of the pipe is restricted by the soil around it.

For the problem of frost heave and thaw settlement, advanced analytical tools, and input functions needed to characterize the components of the design methodology, are required to integrate the various parts of the loading and resistance functions so as to correctly address the loading demand on the pipeline. This section reviews some of the familiar parts of the demand problem, such as the internal pressure and change in temperature, and then reviews how these are integrated into the loading functions for the longitudinal stress components to derive a unified mechanical approach.

The basis of the structural mechanics for pipeline engineering is summarized in Appendix A. For such a straightforward ‘structure,’ a pressurized pipe can actually exhibit fairly complex behavior involving significant stress components in a biaxial stress state.

The resultant mechanical state of the pipeline that arises from the external loads imposed from different sources, causing both hoop and longitudinal pipe stress effects, is referred to as the ‘demand’ on the pipeline. Since the overall resultant is a complex stress state, the demand is best characterized in this combined state – i.e., because the relative magnitudes of the orthogonal components are roughly of the same magnitude, the interaction mechanics must be considered.

Yet, this evaluation of the ‘demand’ is not sufficient for design, since it must be judged where the behavior is acceptable in the design, i.e., whether the ‘capacity’ of the pipe is sufficient to resist the demand. The basis for material regulatory acceptance of the line pipe centers on the yield point for a uniaxial condition. The yield point for pipeline engineering is defined by testing requirements to be the point at which the specified minimum yield strength (SMYS) of the pipe is recorded – 0.5% strain. As noted in Appendix A, this definition of the ‘yield’ does not concisely fit classical textbook definitions of yield, which is often defined as the point at which non-recoverable, i.e., ‘plastic’ deformations, initiate. For example, if the ASAP API 5L X70 pipe material was considered to be governed by Hooke’s law ( $\sigma = E\varepsilon$ , where  $\sigma$  is stress,  $\varepsilon$  is strain, and  $E$  is the modulus of elasticity) to the SMYS of 70 kips per square inch (ksi), the associated strain would be only:

$$\varepsilon = 70\text{ksi} / 29,500\text{ksi} / \text{in} / \text{in} = 0.00237\text{in} / \text{in} = 0.237\%$$

Thus, to reach the strain associated with SMYS, an additional 0.263% strain occurs, which cannot be accounted for by an elastic relationship. Alternative yield point characterizations are defined using an ‘offset’ method where a line with the elastic slope is drawn from a specified strain offset point – again confirming the necessary incorporation of non-recoverable (plastic) deformation just to reach the SMYS of the pipe.

In addition, the SMYS value is defined in a uniaxial condition. Because the orthogonal stress components are roughly comparable in magnitude, the simple uniaxial relations must be extended to consider actual biaxial conditions. Generally, the extensions involve structural mechanics relationships that allow the combined stress conditions to be related back to uniaxial tests and uniaxial stress conditions or ‘effective’ stresses that characterize the biaxial conditions, often by reference to a skewed reference frame.

## 4.1 PRESSURE CONTAINMENT

The governing regulatory document for the ASAP pipeline, 49 CFR 192, addresses the "...design pressure for steel pipe..." in 49 CFR 192.105. The design factor used in this formula for the design pressure is addressed in 49 CFR 192.111.

Although there are provisions for alternative approaches to this design factor, i.e. Alternative MAOP, with additional associated requirements for utilizing this alternative formulation, AGDC has elected to not pursue use of this alternative formulation for the design factor. Thus, requirements relating to this alternative formulation, including those cited in 49 CFR 192.620, are not applicable to ASAP.

The design pressure formula cited in the federal regulations ( $P = (2 St/D) \times F \times E \times T$ ) is recognized as the classical Barlow's formula derived from basic equilibrium considerations (see Appendix A). The derivation does not depend on the material type (e.g., steel, aluminum, etc.), the mechanical state of the pipe material (elastic, inelastic, plastic...) nor consideration of pipe behavior in the orthogonal longitudinal direction. The robustness of this formulation makes it ideal for the focus of pressure containment guidance, both in regulations and consensual standards.

On the other hand, and somewhat because there are no associated limiting conditions arising from the derivation for the application of this formula, there are no associated explicit requirements for other types of loadings that can be deduced from this design pressure formula. In particular, there are no requirements associated with the design pressure formula that impose any conditions or limitations upon the longitudinal stress/strain behavior of the pipeline. There are more exact formulations for thick-walled pipes (generally defined as having a diameter to wall thickness ratio (of less than 20), but typical transmission lines, including ASAP, are thin-walled pipes.

Thus, the design pressure formula cited in the regulations will be met regardless of the design limitations imposed on the longitudinal effects, i.e., if the pipeline diameter, thickness, and operating pressure meet a 72% SMYS requirement at startup, the same combination of these input parameters into the design pressure formula cited in the regulations will produce the same limiting stress of 72% SMYS, and thus identically meet these regulatory requirements indefinitely throughout operations, regardless of the longitudinal behavior. This is a conclusion from the stress mechanics of pipelines, and is not peculiar to any aspect of the ASAP nor to any transmission pipeline.

## 4.2 TREATMENT OF LONGITUDINAL LOADINGS

In contrast to the explicit requirements for the design pressure formula, the federal regulations contain only general guidance for additional types of loadings, and no explicit limitations. General guidance is contained in 49 CFR 192.103 which states:

*Pipe must be designed with sufficient wall thickness, or must be installed with adequate protection, to withstand anticipated external pressures and loads that will be imposed on the pipe after installation.*

More specifics about potential hazards to be investigated are contained in 192.317:

*(a) The operator must take all practicable steps to protect each transmission line or main from washouts, floods, unstable soil, landslides, or other hazards that may cause the pipeline to move or to sustain abnormal loads...*

If additional thickness is found to be required for reasons other than pressure containment, the allowable pressure must not be increased through a re-computation of the design pressure formula to take advantage of this additional thickness as per 49 CFR 192.105.

The requirements of 49 CFR 192 quoted above, though general in nature, are an explicit reminder to all operators that prudent oversight of the potential detrimental effects from external loads requires diligent investigation and cannot be waived. To satisfy this requirement, the pipeline industry has addressed the lack of explicit requirements in the regulatory framework through consensual standards so as to satisfy the general regulatory requirements.

The U.S. gas industry accepted standard for requirements in areas where the regulations give only general guidance is ASME B31.8, Gas Transmission and Distribution Piping Systems. To be clear, where there is a disagreement in ASME B31.8 with the regulations, the regulations are followed.

In particular, ASME B31.8 Section 833 addresses longitudinal loads and is the basis for industry analysis of longitudinal stresses – in compliance with the need for such an analysis of external loads as required by the regulations, and in no way contradictory or contraindicating any specific requirements in the regulations as to the details of such an undertaking. These requirements are incorporated in all commercial pipe stress analysis programs such as CAESAR II and AUTOPIPE. Section 833.3 of ASME B31.8 sets the longitudinal stress requirements for restrained pipe with a limitation of 90% of SMYS, while Section 833.4 sets the combined stress requirements for restrained pipe with a limitation of 90% of SMYS for long term loading and 100% of SMYS for short term loading (ASAP has no temperature derating), while Section 833.5 details the requirements for design to utilize a stress greater than yield.

AGDC follows the procedure as described above, which adheres to regulatory requirements, using explicit industry recommended procedures to satisfy those requirements. AGDC has identified no exceptions to this described procedure, although additional details for utilization of a strain based criteria require additional and specific criteria.

### 4.3 EFFECTIVE STRESS

To characterize the combined effects of the operational circumferential load, i.e. the hoop stress due to pressure containment, with the longitudinal effects from frost heave, a method of determining the combined effect is required. Further, this combined effect must be able to be compared to the actual material tests that are typically performed and/or required for material requisition, which are uniaxial.

As noted above, the SMYS value is defined in a uniaxial condition. Again, because the orthogonal stress demand components are roughly comparable in magnitude, the simple uniaxial relations must be extended to relate to the actual biaxial conditions. Generally, the extensions involve structural

mechanics relationships that allow the combined stress conditions to be related back to uniaxial tests and uniaxial stress conditions or ‘effective’ stresses that characterize the biaxial conditions, often by reference to a skewed reference frame. This section presents the background for the ‘effective stress’ combinatorial techniques, which are used within the frost heave design methodology.

The two most commonly used theories for determining effective stresses in pipelines are the maximum shear stress theory, commonly referred to as the Tresca theory, and the maximum distortion energy theory, commonly referred to as the von Mises’ theory. The effective stresses that result from these theories are both represented in ASME B31.8.

The first approach is the Tresca yield criterion, and as described in more detail in Appendix A, for the biaxial stress conditions that exist in pipelines the yielding criterion is expressed as follows:

$$|\sigma_H| \leq \sigma_y \quad \text{and} \quad |\sigma_L| \leq \sigma_y \quad \text{and} \quad |\sigma_H - \sigma_L| \leq \sigma_y$$

where:

$\sigma_H$  is the hoop stress;  
 $\sigma_L$  is the longitudinal stress; and  
 $\sigma_y$  is the yield stress of the pipe.

The hexagonal Tresca yield function is illustrated in longitudinal stress vs. hoop stress space in Figure 12 for an elastic-plastic material with a yield strength of 70 ksi. Any stress falling within the hexagon indicates the material behaves elastically while points on the hexagon indicate the material is yielding. This criterion is implemented under B31.8 Section 833.4 to limit combined stress for restrained pipe as:

$$|\sigma_H + \sigma_L| \leq k * S * T$$

where:

$k$  is an allowable stress multiplier (for loads of long duration,  $k$  is 0.90, and for occasional non-periodic loads of short duration it is 1.0);  
 $S$  is the pipe SMYS; and  
 $T$  is the temperature derating factor ( $T=1.0$  for temperatures  $\leq 250^\circ\text{F}$ , per B31.8 Section 841.116).

The second approach is the von Mises’ yield criterion, which defines a different effective stress to compare against the uniaxial ‘yield point’ as:

$$\sqrt{\sigma_1^2 - \sigma_1 * \sigma_2 + \sigma_2^2} = \sigma_y$$

This is the equation of an ellipse as also shown in Figure 12 for an elastic-plastic material with a yield strength of 70 ksi. Any stress falling within the ellipse indicates the material behaves elastically while points on the ellipse indicate the material is yielding. This criterion is implemented under B31.8 Section 833.4 to limit combined stress for restrained pipe as:

$$\sqrt{\sigma_L^2 - \sigma_L * \sigma_H + \sigma_L^2} \leq k * S * T$$

Figure 12. Illustration of Tresca and von Mises Yield Functions

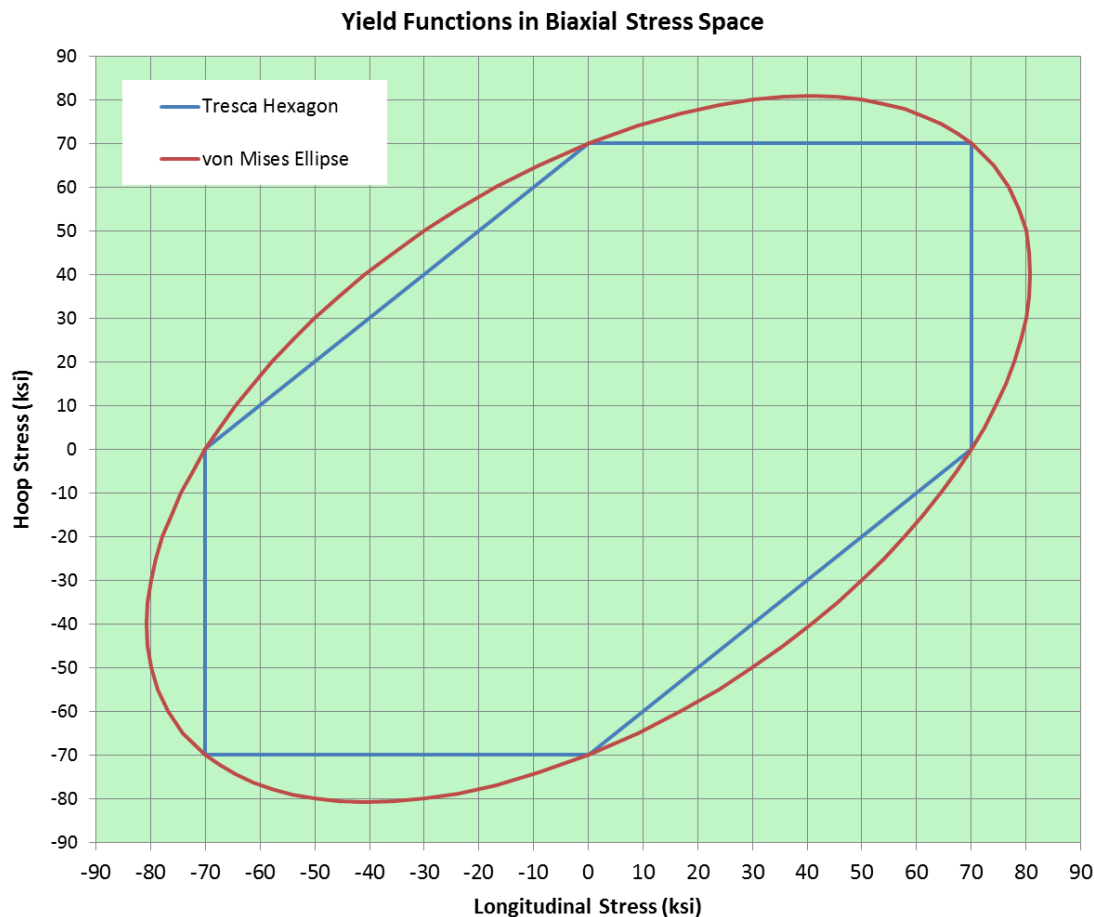

Note the Tresca hexagon meets the von Mises ellipsoid at certain points around the periphery of the ellipsoid and is elsewhere contained within the ellipsoid. Since points located within the yield function boundaries are said to define elastic states while those on the yield function boundaries define a yielded condition, the Tresca criterion can be seen to be slightly more conservative than the von Mises criterion. The differences, however, are small and both approaches are accepted. In general, the von Mises theory is the more widely used in computer applications and advanced inelastic analysis because of its smooth surface and corresponding continuously differentiable function. The Tresca theory, because of its simplicity, is often used in manual/hand calculations.

#### 4.4 CRITICAL SPAN

The magnitude of pipe strain induced by displacement of the trench is dependent, of course, on the magnitude of the trench displacement – whether this displacement is vertically upward as for heave, or vertically downward as for settlement. Less obvious is the magnitude of the pipe strain is also dependent upon the length over which this ditch displacement acts – such length is termed the ‘span’ of the imposed displacement.

(In the following, the ditch displacement is assumed to be due to thaw settlement, although the concept applies equally to heave).

For small spans, as the thaw displacement amplitude increases, the pipe strains will also increase, until the pipe will ‘bridge’ over the length of the displacement. This situation is illustrated schematically in Figure 13.

**Figure 13. Pipe bridging over a Short Settlement Span**

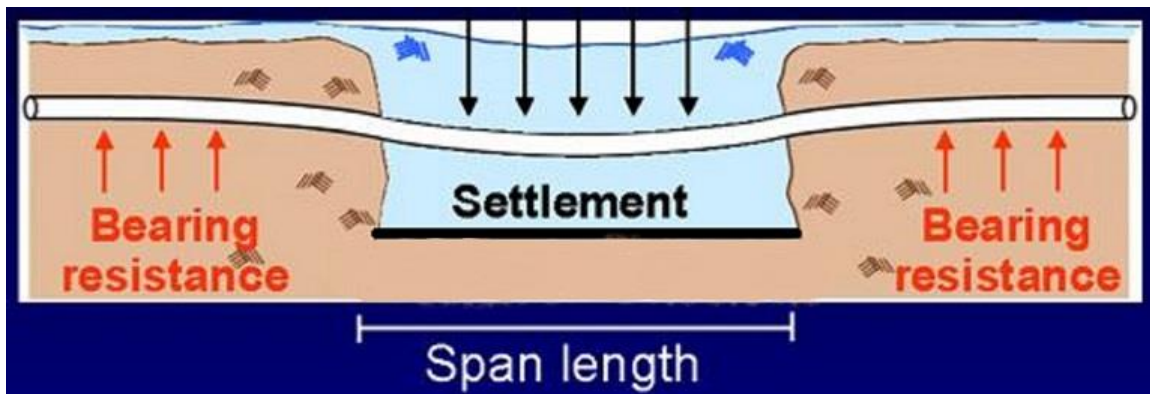

In Figure 13 the pipe is seen to be in bending without contact with the lower soil surface – i.e. the pipe bending, and the associated pipe strain, does not increase beyond the point at which the pipe will freely ‘bridge’ this span. The associated plot of pipe strain with increasing thaw settlement for this span is shown in Figure 14.

Figure 14. Maximum Pipe Strain Value – ‘Bridging’ Through the Imposed Settlement Span

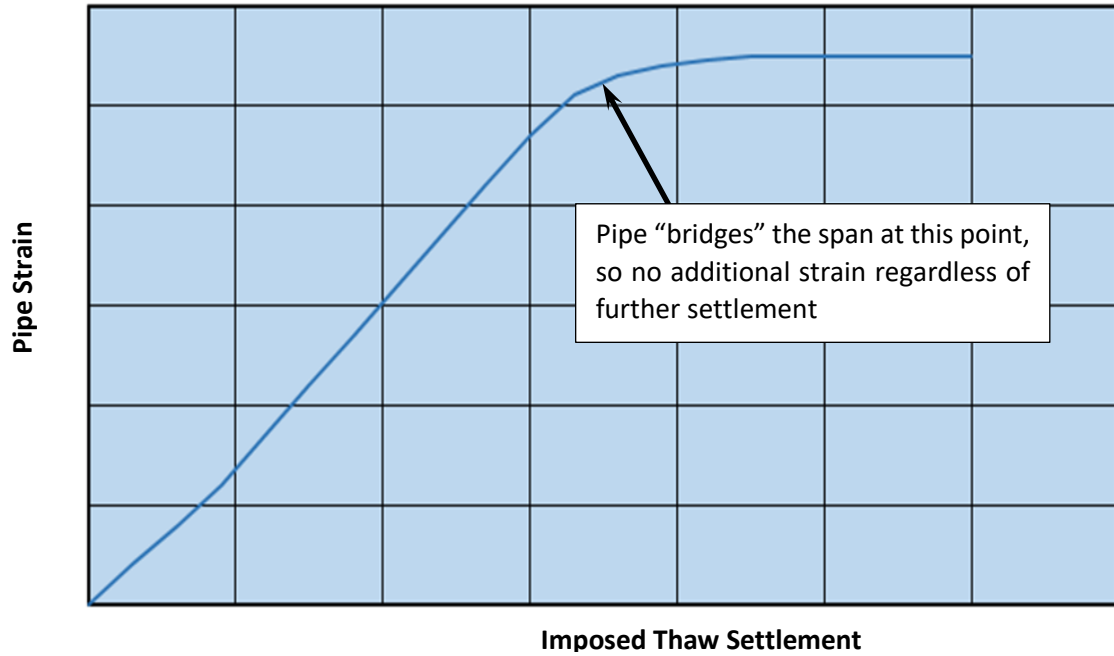

On the other hand, for settlement which occurs over a large span, the maximum pipe strain will occur entirely within the area between the settling and non-settling regions – i.e. it is unaffected by the length of the settling span. This is shown schematically in Figure 15.

Figure 15. Long Span Differential Settlement

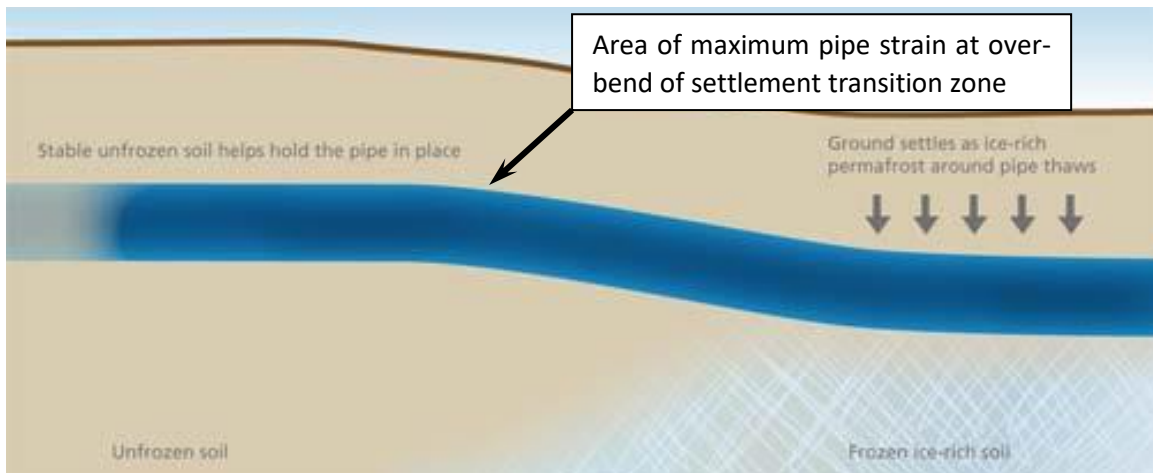

Reference: [www.neb-one.gc.ca](http://www.neb-one.gc.ca)

At some length of settlement span between these two extremes of short settlement span and long settlement span, pipe strain is found to achieve a maximum magnitude. The span for which the pipe strain is found to be a maximum magnitude for a fixed amplitude of settlement is said to be the ‘critical span’ for that amplitude. The situation is schematically shown in Figure 16. The procedure to derive and use the data of Figure 16 is summarized:

- The pipe design parameters of the area being investigated are defined: depth of cover, operating pressure, type of soil
- Using the design parameters applicable to the design situation being analyzed, a first trial span of 80ft is analyzed to find the value of pipe strain for the range of settlement amplitudes from 6 inches to 60 inches imposed on this 80-foot span– the set of results for this 80-foot trial span (pipe strain vs settlement amplitude) is plotted as the cyan line titled “Span = 80 ft” in Figure 16
- The second trial span of 100 feet is analyzed to find the value of pipe strain for the range of settlement amplitudes from 6 inches to 60 inches imposed on the 100-foot span– this is plotted as the orange line titled “Span = 100 ft” in Figure 16
- The process is repeated for succeeding spans of 120 feet through 275 feet – each set of results is separately plotted on Figure 16 as shown
- For the specific settlement amplitude evaluated, the Figure is entered to find the maximum strain for any span length. Thus on Figure 16, the imposed settlement evaluated at the area of interest is within the circled area – and within this area it shows the 140-foot span produces the highest pipe strain for this range of settlement amplitudes. Thus, for this design situation, 140 feet is termed the ‘critical span’
- The strain found at this critical span (termed the ‘strain demand’) is then compared to the allowable strain (the ‘strain capacity’).
- If the strain demand is less than the allowable strain, this situation is deemed acceptable.
- If the strain demand exceeds the allowable strain, then this situation is unacceptable and a mitigative solution is required. The various mitigative solutions discussed in Section 9.2 are investigated to find the solution that is compatible with the site requirements and reduces the strain demand to acceptable values.

Figure 16. Critical Span Evaluation Example

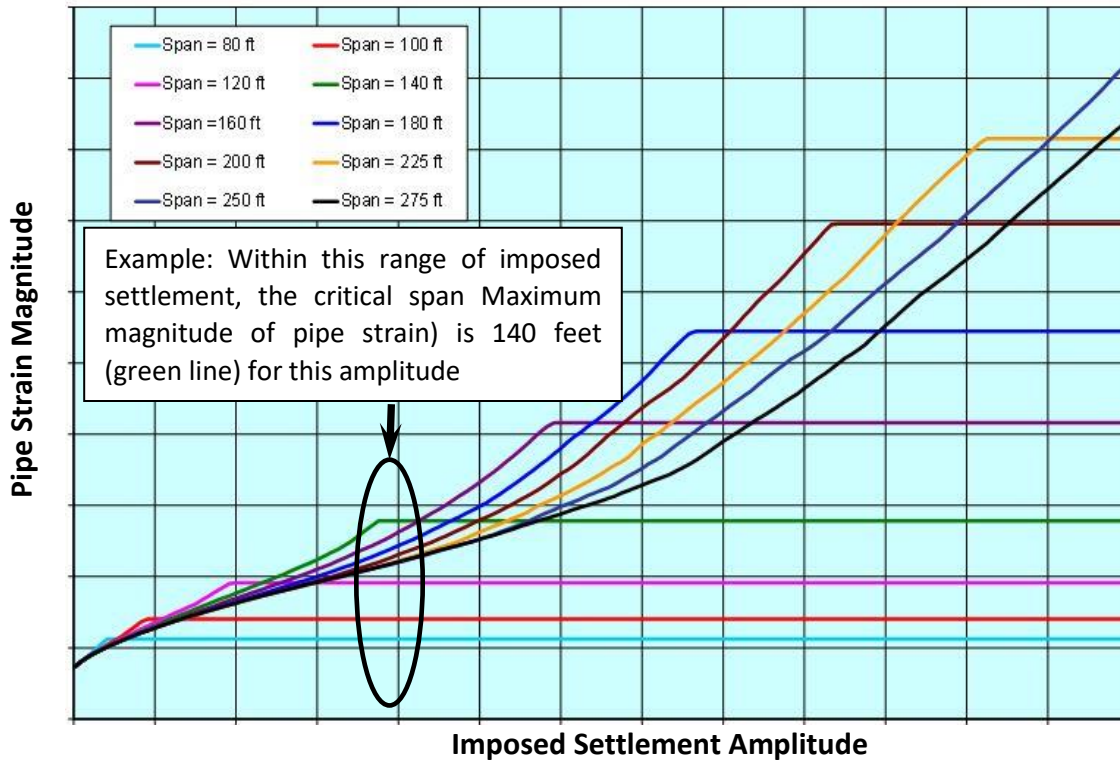

The concept of critical span is used in the analyses of pipe strain in order to ensure the maximum possible pipe strain magnitudes are found for any pipe displacement situation. That is, for any given amount of settlement which could be expected by the pipe, all lengths of spans are analyzed. The results are reviewed and the settlement span which produced the maximum pipe strain magnitudes controls the design and is said to be the critical span for design.

This concept of critical span is crucial to the analysis since the result supplies confidence the pipe strain magnitude which controls the design for the given route situation is thereby independent of the actual settlement length in the field at the site of the analysis. Said another way, by choosing the worst strain from all potential situations the analysis ensures a conservative value of the settlement span. A consequence of this procedure is it does not require the route evaluation to determine the actual span length for any design situation – since all spans are considered, and the worst pipe strain is selected from all the considerations, the actual situation of span length and pipe strain must be no greater than the design solution.

Note, although this evaluation is used during design, the conservative evaluation can be rendered less conservative, and more appropriate, if the actual route settlement span is known. Such a situation could arise during Operations when site specific issues occur and require further detailed evaluation. During design, however, such specific situations would be relatively rare.

#### 4.5 APPLICATION OF THE METHODOLOGY

The methodology described above for the combination of the orthogonal stresses in the pipe that arise from the operational load acting concurrently with the imposed differential displacement, are effectively combined within the analytical pipe stress program PIPLIN, which is described in more detail in Section 5 of this report.

## 5. STRAIN DEMAND DETERMINATION

### 5.1 PIPE-SOIL INTERACTION ANALYSIS OVERVIEW

The mechanism of pipeline thaw settlement and frost heave have been investigated in detail for many previous Arctic pipeline projects. Thaw settlement occurs when ice-rich frozen soil below the pipe thaws. Several sources contribute to the soil thawing including; right-of-way clearance, construction grading, regional climate change and operation of a pipeline with warm or hot contents. As the soil progressively thaws, downward settlement of the pipe is produced by thawing of frozen soil in which it is buried and consolidation at the thaw front. The gravity and down drag loads push the pipe downward as bearing support is reduced by settlement. The amount of consolidation produced by a given increase in thaw depth can be affected by the type of soil, the absence or presence of ice lenses, and other factors. Frost heave occurs when a chilled pipeline freezes water in frost-susceptible soil in which it is buried. As the soil freezes, it expands and forms a frost bulb around the pipe. Upward heave of the pipe is produced by swelling at the bulb face as the bulb grows.

Significant pipe stresses and deformations can occur for thaw settlement and frost heave due to differential movement in the soil which causes bending, and thus longitudinal stress/strain in the pipe. For thaw settlement, this could occur when the buried pipeline runs between soils that exhibit different levels of downward movement. As an ice-rich soil thaws in a non-thaw-stable soil section, it consolidates, and the pipe settles, while the pipe might exhibit a different magnitude of consolidation in the adjacent soil section. This results in a differential vertical displacement (or settlement) profile across the transition between the two soil sections, which causes bending of the pipe. Similarly, when the pipe spans a frost susceptible soil and the initially thawed subsurface freezes due to the presence of a chilled pipe, a differential vertical heave displacement profile can be produced across the transition between the soil sections. In either case, the differential displacement can result in significant pipe deformations due to pipe curvature and axial force effects. Uniform displacement in either case would not result in pipe bending concerns.

The strain demand analyses for differential displacement of ASAP is evaluated using the PIPLIN computer program (SSD 2011). PIPLIN is a special-purpose finite element program developed to perform stress and deformation analysis of two-dimensional pipeline configurations. The analyses consider several nonlinear aspects of pipeline behavior, including pipe yield, large-displacement effects, and nonlinear frozen soil support.

A heaving segment of pipe causing differential movement is illustrated in Figure 17, while a settling section of a pipeline together with a schematic view of the corresponding PIPLIN model is illustrated in Figure 18. To reduce the required size of the model, a symmetric boundary condition (i.e., zero rotation and zero longitudinal translation) is normally imposed at the end of the model corresponding to the center of the settled span. The sufficient model length is such that the boundary condition specified at the remote end of the model has no influence on the key analysis results. The pipe is typically assumed to be initially straight with a uniform depth of soil cover.

The pipe is modeled using beam type elements in which the stresses and strains are monitored at a number of fiber points around the pipe cross section at the element ends. PIPLIN achieves computational economy by considering a plane of symmetry through the pipe centerline (e.g., the vertical plane in frost heave model) so that only one-half of the pipe section is analyzed. In these analyses, the pipe cross-section is assumed to remain circular and plane sections are assumed to remain plane. The pipe element accounts for large displacement effects (i.e., changes in the equilibrium due to large displacements) by adding geometric stiffness coefficients to the element stiffness matrix. This allows PIPLIN models to accurately capture important column buckling and cable tension effects.

Figure 17. Differential Frost Heave

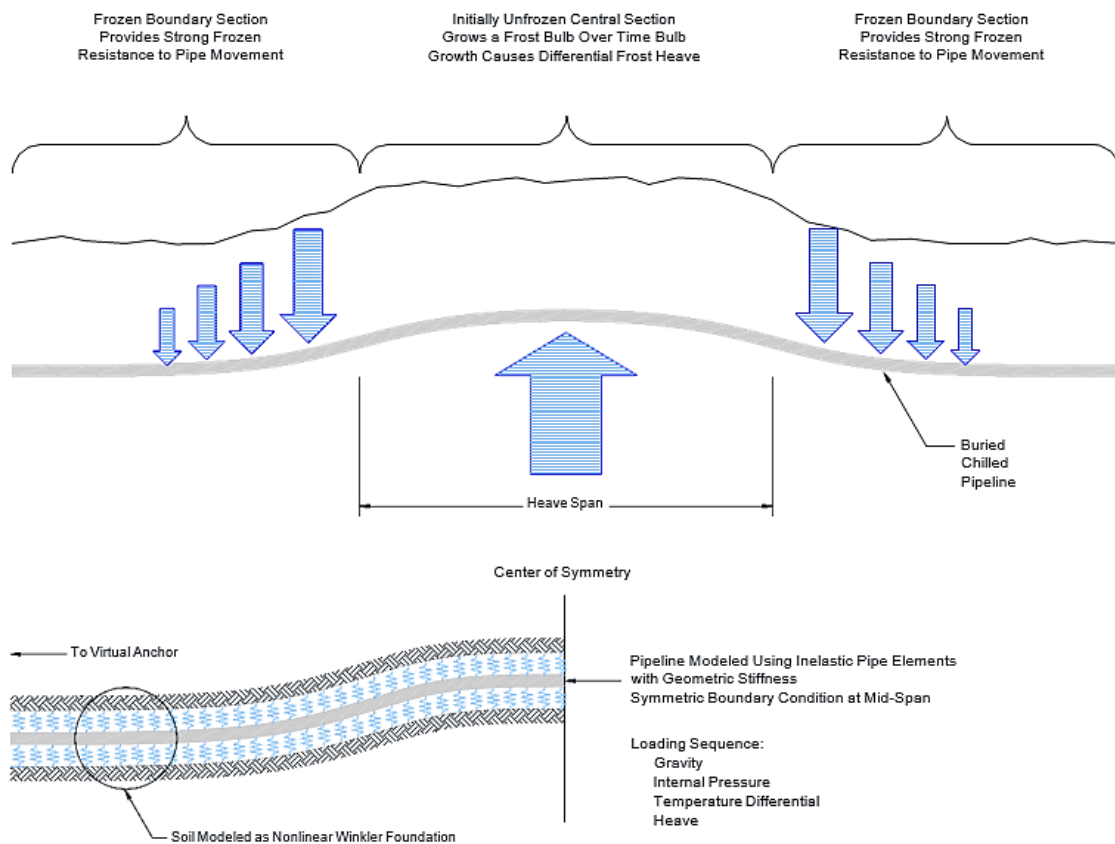
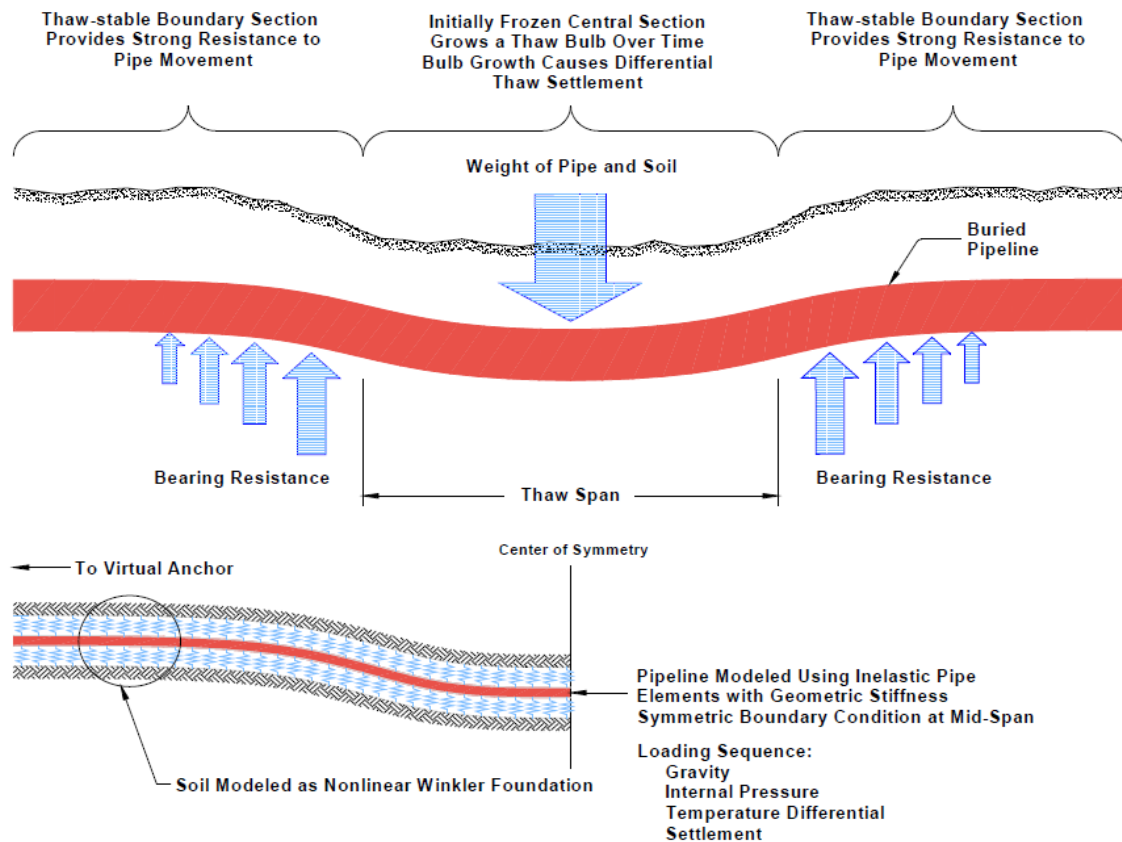

Figure 18. Differential Thaw Settlement and Model



Pipe yield at the fiber points around the pipe cross section is taken into account assuming the von Mises yield criterion so that interaction between hoop and longitudinal stresses is included. The pipe steel material is modeled using the Mroz (Mroz 1967) multi-linear kinematic hardening plasticity model which is able to accurately capture anisotropic pipe steel stress-strain relationships (e.g., pipe that has different stress-strain curves in the longitudinal tension/compression vs. hoop tension/compression directions). The pipe material model provides a very reasonable representation of steel behavior under monotonic, unloading and cyclic load conditions.

The soil is modeled as a nonlinear Winkler foundation. This means the soil support is idealized as a series of discrete, independent, nonlinear springs lumped at the element midpoints. In effect, this assumes that the soil can be regarded as a series of plane 'slices.' The basic assumption is the slices deform independently of each other. The pipe-soil springs are assumed to have uniform properties over any pipe segment.

The analyses are typically initiated with the application of gravity, internal pressure and temperature differential loads. If desired, a hydrostatic test loading/unloading sequence can be considered prior to applying the operating loads.

For frost heave, a multi-year (typically 20 to 30 years) frost heave simulation of the pipe-soil interaction model is then undertaken. The frost heave analyses are nonlinear time-history analyses performed using small steps through time. Within the heave span, the frost bulb geometry and frost heave vary with time. Seasonal variations of the uplift, longitudinal, and bearing creep soil temperatures (and corresponding resistance) are also specified with each heave time step. The heave is imposed progressively at the base of the pipe-soil springs within the heave span. The amount of heave at the ditch bottom is calculated separately for each transverse pipe-soil support in turn accounting for the important pressure feedback from the pipe at the base of the frost bulb. A transition length between the finite length section of heaving soil and the adjacent non-heaving soil section can be specified if desired.

Thaw settlement analyses also start with the base operating conditions and then impose incremental downward displacements to simulate the thaw consolidation. Thaw settlement does not require consideration of the pressure feedback, so the analyses are relatively straightforward when compared to frost heave analyses.

The complete pipe-soil deformation state is established at each increment of the analysis. The program output includes pipe displacements, soil support deformations and reactions; pipe axial forces, bending moments and curvatures; axial, hoop and von Mises stresses and axial and hoop strains in the pipe. The maximum pipe tension and compression strain demands are established at each output state to provide progressive plots of these key response quantities.

## 5.2 PIPE MATERIAL PROPERTIES

As implemented in PIPLIN, the Mroz plasticity model assumes the pipe material yields according to the von Mises theory under plane-stress conditions. The bi-axial stress-strain behavior is defined by a set of progressively larger, non-overlapping elliptical yield surfaces in longitudinal stress vs. hoop stress space. The Mroz theory specifies that as the steel yields, the individual ellipses translate without changing size or shape, which is the well-known kinematic hardening assumption. The theory also specifies the direction of movement of each ellipse – essentially, any ellipse moves so that when the stress point reaches the next larger ellipse, the yielding ellipses do not overlap.

One of the key features of the PIPLIN steel model is the elliptical yield functions can be shifted to initial positions in order to mimic the effects of the pipe expansion phase of the Uing and Oing forming of pipe (UOE) manufacturing process. The shifts are selected such that the analytical uni-axial stress-strain results closely match a set of uniaxial longitudinal tension (LT), hoop tension (HT) target stress-strain curves. For pipe steel fabricated with the UOE process, the ellipses tend to be shifted along the HT axis. The pure HT ellipse shifting pattern tends to result in an elevated proportional limit and relatively sharp (abrupt) yielding point for the HT curve (due to work hardening and bunching of the ellipses) and a low proportional limit with progressive (well rounded) yielding for the hoop compression (HC) curve (due to Bauschinger effect). The steel model is well suited for capturing key aspects of the anisotropy patterns typically observed in UOE pipe.

As described in *A Material Model for Pipeline Steels* (Hart et. al 1996), an 8-parameter model can be used to develop input material properties for strain levels below 2%. This portion of the steel stress-strain curve can be divided into 3 regions, namely: a linear elastic region, a curved transition or ‘knee’ region, and an essentially linear ‘fully plastic’ region. The term ‘fully plastic’ is not strictly correct since the steel still has a finite hardening modulus. The model requires the HT and LT curves have the same elastic modulus and the same fully-plastic strain hardening modulus. However, the shape of the HT and LT curves in the yield transition region can be different i.e., the curves can have different proportional limits and different degrees of ‘sharpness’ or ‘roundedness’ through the transition from elastic to fully-plastic conditions. The strength levels of the curves in the fully-plastic strain hardening region need not be the same. A 2-root fitting process can be used to determine the ellipse sizes and initial shifts required to closely match a given ‘target’ LT-HT pair of stress-strain curves (as well as a 3-root fitting process when a ‘target’ LT-HT-LC (longitudinal compression) triple of stress- strain curves is available).

## 5.3 GEOTHERMAL INPUT

### 5.3.1 Frost Heave

Frost heave is associated with growth of a frost bulb around the chilled pipe and it is assumed that heave is produced by swelling at the bulb face as the frost bulb grows wider and deeper (Figure 19). The amount of heave for a given increase in frost bulb depth is influenced by several parameters including the type of soil, the availability of moisture, the speed with which the frost bulb grows, the bearing pressure exerted by the pipe on the ditch bottom and other factors. In addition, the amount of movement at the ditch bottom depends on the depth of the frost bulb, with a given amount of swelling producing less ditch bottom heave as the frost bulb gets progressively deeper. Free heave is the heave that would occur if the pipeline provided no resistance to movement. Restrained heave, which is less than the free heave, is the heave that results accounting for the pipeline's resistance to movement which tends to increase the amount of pressure at the base of the frost bulb. In summary, evaluation of the development of frost heave, especially since it is interdependent with the developing pipe restraint response, requires a complete description of the subsurface geothermal state.

Figure 19. Frost Bulb Schematic

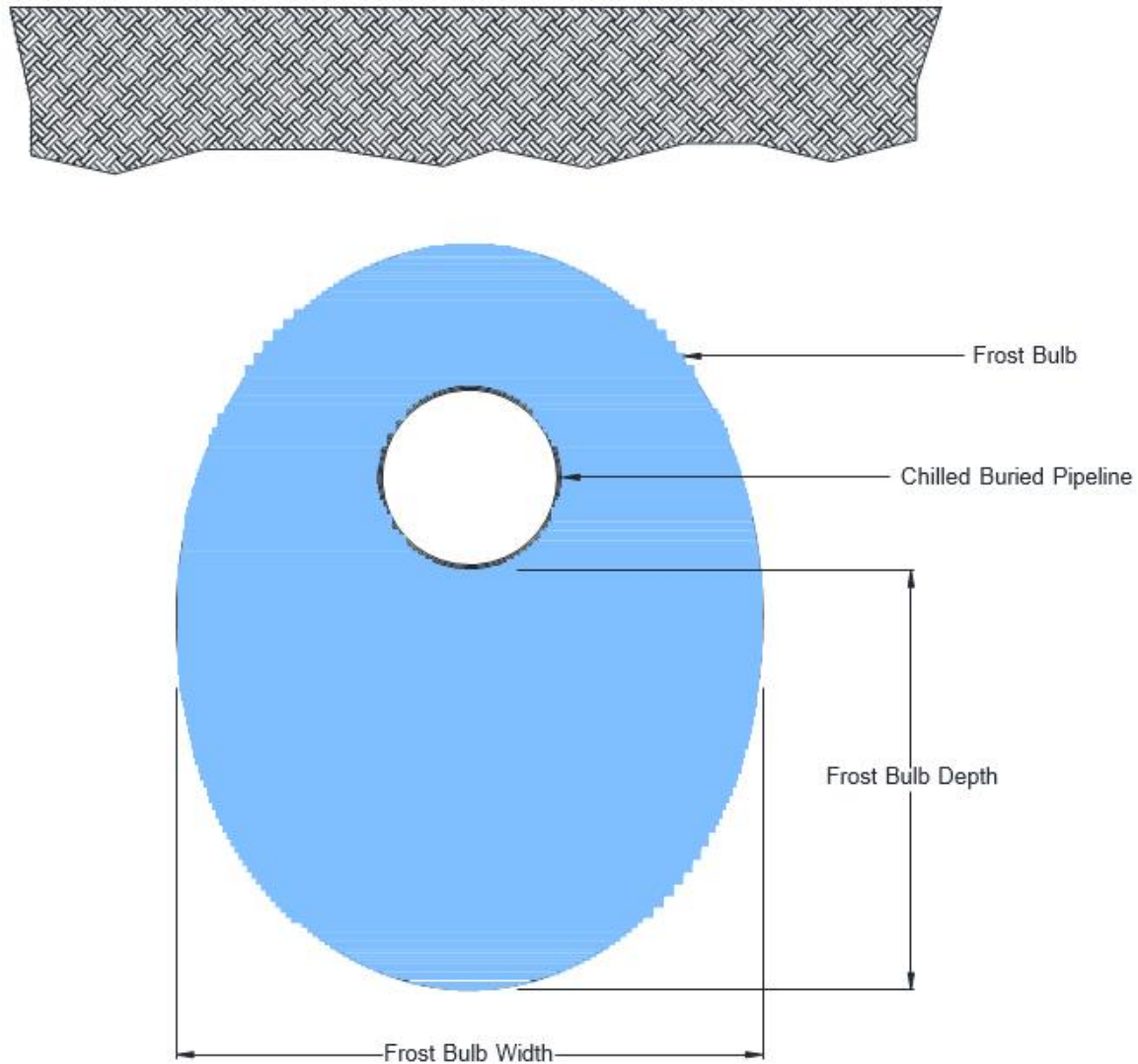

PIPLIN analyzes the effects of restrained frost heave by treating heave movements as equivalent support ‘settlements,’ applied at the ditch bottom (i.e., at the base of the bearing springs). Because heave originates at the frost bulb face, a theory is needed to convert swelling of the soil into ditch bottom movements. PIPLIN has several different options for specifying pipeline frost heave effects. The ‘Revised Formula Method’ is the option selected for the ASAP Project. In the Revised Formula Method, the program calculates ditch bottom movements using the segregation potential theory (Konrad 1981) given certain information describing the frost bulb properties.

The following time-independent parameters are specified:

- A reference pressure “ $P_o$ ” to be used in the segregation potential equation.

- The frost bulb density “ $\gamma$ ” which is used to calculate the soil pressure at the frost bulb base due to bulb self-weight.
- The equivalent burial depth “ $D_o$ ” which is used in the calculation of soil pressure.
- The initial overburden force correction term “ $F_o$ ” which is used in the calculation of soil pressure.

In addition to the time-independent parameters described above, time-histories of the following frost bulb and soil properties are provided as an input table:

- Frost bulb depth “ $D$ ” below pipe.
- Shear force per foot of pipe “ $S$ ”. In general, the shear force term can be due to side shear and/or end shear effects. Note that because a time-history of  $S$  is input, seasonal variations can be directly included.
- Bearing width “ $B_s$ ” at the base of the frost bulb over which the shear force  $S$  is assumed to be distributed. That is, the soil bearing pressure at the frost bulb base due to  $S$  is  $S/B_s$ .
- Bearing width,  $B_F$ , at the base of the frost bulb over which the ditch bottom bearing force,  $F$ , is assumed to be distributed. The soil bearing pressure at the frost bulb base
- Temperature gradient “ $G$ ”, at the frost front.
- The coefficient “ $a$ ” to be used in the segregation potential equation.
- A reference segregation potential “ $SP_o$ ” at the reference pressure “ $P_o$ ”.

At any given time “ $t$ ” and at any given point within the heaving section of the pipe, the values of  $D(t)$ ,  $S(t)$ ,  $B_s(t)$ ,  $B_F(t)$ ,  $G(t)$ ,  $a(t)$  and  $SP_o(t)$  can be obtained from the input time-history table. Note that for most applications, the values of  $a$  and  $SP_o$  are constant with time. One exception to this is for a layered soil profile where  $a$  and  $SP_o$  may vary with depth. The variation with depth can be considered indirectly as a variation with the times the bottom of frost bulb reaches the different soil layers.

The bearing force  $F$  is obtained from analysis of the interaction between the pipe and soil, and varies with location along the pipe as well as with time. If overburden (soil plus pipe) loads are specified, the initial pipe bearing force will equal the overburden soil weight plus the pipe weight. The initial value of the pressure for heave calculations will thus include the effect of the soil weight at the ditch bottom level (in the  $\gamma D_o$  pressure term) plus the effect of the overburden soil weight (in the  $(F-F_o)/B_F$  pressure term). The parameters  $D_o$  and  $F_o$  are selected to provide the desired initial pressure for heave calculations. The shear resistance term  $S$  can be used to represent the resistance provided by the unfrozen soil on the sides of the soil ‘block’ above the widest point of the frost bulb and/or the resistance provided by the frozen soil ‘abutments’ at each end of the heaving span.

When the frost bulb depth increases during an analysis time step, the heave rate,  $\dot{H}(t)$ , is calculated using the segregation potential equation:

$$\dot{H}(t)_0 = 1.09SP(t)e^{a(t)(P(t)-P_o)}G(t)$$

and the heave increment is given by:

$$\Delta H = \dot{H}(t)\Delta t$$

### 5.3.2 Thaw Settlement

Thaw settlement is associated with the thawing of frozen materials either fine grain frozen soils with a high water content, or massive ice bulb. The soil consolidation from thaw is not materially dependent on the pipe response, so the displacement can be developed without the interdependent evaluation required for frost heave. Thus, PIPLIN only requires the magnitude of the resultant soil consolidation in the settling region that results from the geothermal analysis. This is imposed as an imposed displacement at the base of the supporting soil – no reference to further details of the geothermal analysis is required.

## 5.4 SOIL RESISTANCE CHARACTERIZATION

The soil is modeled in PIPLIN as a nonlinear Winkler foundation, i.e., the soil support is idealized as a series of discrete, independent, nonlinear springs lumped at the pipe element midpoints. The longitudinal pipe-soil springs provide resistance to longitudinal motion and the transverse pipe-soil springs provide resistance to transverse motion where longitudinal and transverse are defined relative to the original, un-deformed, geometry of the pipe axis. The pipe-soil springs are assumed to have uniform properties over any pipe segment.

Longitudinal pipe-soil spring supports are distributed along the pipe axis to represent cohesive resistance of the soil to longitudinal displacement of the pipe. For each pipe element, the longitudinal pipe-soil spring state is determined from the average of the longitudinal displacements of the pipe nodes at each end of the element. The supports are assumed to provide resistance to longitudinal movement up to a specified force per unit length of pipe and then to slip at constant load.

Transverse pipe-soil spring supports are distributed along the pipe to represent the transverse (T) resistance of the soil (e.g., upward or downward). For each pipe element, the transverse pipe-soil spring state is determined from the average of the transverse displacements of the pipe nodes at each end of the element. In any pipe segment, different properties may be specified for downwards/bearing (+T) and upwards/uplift (-T) loading on the soil. The soil bearing (+T) resistance is the resistance of the trench bottom to downward movement of the pipe. For ASAP frost heave simulations, the bearing resistance of the soil is accounted for in the model using elasto-plastic springs. The strength of the bearing spring is typically selected to correspond to the minimum annual pipe temperature. For ASAP, the pipe-soil bearing resistance also considers temperature and bearing pressure dependent secondary creep. The soil uplift (-T) resistance is the resistance of the soil to upward movement of the pipe. The ASAP frost heave analyses considers the temperature, displacement rate and displacement dependence of the uplift pipe-soil springs using PIPLIN's uplift analysis capability. Thaw settlement analyses involve thawed soil strengths which are consistent with more familiar soil relationships.

In Arctic regions for frost heave, the soil around a buried pipeline may be completely frozen during the winter but significantly thawed during the summer. Also, the temperature of the pipe contents may be intentionally cycled so as to create a thaw annulus around the pipe as a means of mitigating frost heave. Under these conditions, the resistance of the soil can vary significantly. PIPLIN's uplift, longitudinal pipe-soil spring (L-spring) and creep analysis features allow strength variations of this sort to be taken into account during a frost heave simulation. During the course of a frost heave analysis, a typical year is broken up into several (typically 12) multi-step analysis sequences such that the near sinusoidal pipe and soil temperature variation, and the corresponding soil resistance variations are approximated using a piecewise-linear variation through time. A typical 'steady-state' annual cycle is normally assumed to apply for each year of the analysis.

For thaw settlement analyses, the pipe is not a chilled source so the soil properties that affect the pipe movement are unfrozen so do not require time-dependent evaluations.

#### 5.4.1 Uplift Resistance for Frost Heave

PIPLIN's uplift analysis feature allows for the specification of uplift soil spring strengths that depend on the uplift spring displacement, the uplift soil temperature, and the displacement rate of the uplift spring. Uplift force-displacement relationships can be specified based on a piecewise-linear 'backbone curve' defined using up to 8 uplift force-displacement coordinates for up to 60 different soil temperatures at up to 10 different uplift deformation rates. The uplift strength will typically, but not necessarily, increase with decreasing soil temperature and increasing uplift deformation rate and will typically, but not necessarily, decrease with increasing uplift displacement after reaching a peak strength value at a relatively small displacement. For uplift soil temperatures, displacements and deformation rates between the specified input values, the strengths are obtained using 2-way linear interpolation between the input backbone relationships for different uplift displacement rates and uplift temperatures. For uplift temperatures and displacement rates outside of the specified input range, the backbone curve corresponding to the nearest specified temperature or displacement rate is used. For displacements greater than the last specified displacement, the last specified strength is assumed. Within a given uplift analysis step, the uplift properties at each spring are modified based on the uplift temperature, the current rate of uplift spring displacement, and the current uplift displacement.

As described above, PIPLIN's uplift analysis option allows for consideration of the displacement and displacement rate dependence of the pipe-soil uplift springs as well as the temperature dependence as influenced by seasonal ground surface and/or pipe temperature variations. The approach for the ASAP frost heave analyses is to use a single uplift soil temperature (32°F) corresponding to thawed soil conditions together with two or more uplift soil temperatures to cover the range of frozen soil temperature conditions encountered over a typical year of operation during the frost heave analysis. The uplift temperature values and the time between adjacent temperature values are specified for a typical 1 year analysis cycle. The uplift soil temperature will be taken as equal to the pipe temperature or some measure of the average backfill temperature, both of which have a seasonal variation that resembles a sine wave. The ASAP Project computes the thawed and frozen uplift pipe-soil spring properties based on publicly available geotechnical procedures (e.g., see (COLTKBR 2003) and (COLTKBR 2007)).

### 5.4.2 Bearing Resistance

PIPLIN has sophisticated creep support analysis capabilities including pressure and temperature dependent primary and secondary creep for frozen soils for frost heave analyses. For frozen soils, creep properties can be associated with any transverse segment support. The pressure and temperature dependence is considered by specifying the creep parameters at up to 5 temperatures for up to 20 pressures. For temperatures and pressures within the specified temperature and pressure ranges, the creep parameters are obtained by linear interpolation between input values. For temperatures and pressures that are outside of the specified temperature and pressure ranges, the creep parameters associated with the nearest input temperature or pressure are used.

For the ASAP frost heave analyses, secondary creep is evaluated in the bearing pipe- soil supports. Including secondary creep has the effect of adding a secondary creep dashpot – a viscous support element that provides resistance proportional to the velocity – (with a dashpot coefficient  $C_s$ ) in series with the elastic-perfectly plastic bearing spring associated with each pipe element. The dashpot coefficient  $C_s$  is specified to be dependent on both temperature and the bearing pressure between the pipe and soil, typically decreasing with increasing temperature and pressure.

For thawed soil properties, The ASAP Project uses publicly available geotechnical procedures (COLTKBR 2007) to compute the bearing spring and dashpot properties.

### 5.4.3 Longitudinal Resistance

In any segment, the strength of the L-spring can be defined to vary with temperature for frozen soils, by specifying up to 20 temperatures and up to 20 corresponding strengths. For temperatures between the specified values, the strengths are obtained by linear interpolation. For temperatures outside of the specified range, the strength corresponding to the nearest specified temperature is assumed. An initial temperature (the same for all segments) is specified, and this determines the L-spring strength at the beginning of the analysis. The effect is to place an upper limit on the strength of the L-spring. If this strength is exceeded at any location, the stiffness is reduced to zero. The effect, initially, is exactly as if a stiffness ( $K$ ) value of zero had been specified for the support. However, the behavior differs from that with  $K=0$ , because the strength can subsequently be changed.

In any load sequence, it can be specified the longitudinal (L-spring) soil temperature changes progressively, so the cutoff on the strength also changes. If the strength decreases, the resistance developed by the support is progressively reduced, leading to a redistribution of load along the pipeline. If the strength increases, the support force remains unchanged but the stiffness becomes nonzero (the value on the basic force-displacement relationship for the current support force). In this case there is no redistribution of load. The strength may be cycled in any desired way, for as many seasonal cycles as desired.

As described above, L-spring analysis allows for consideration of the temperature dependence of the pipe-soil longitudinal springs as influenced by seasonal surface and/or pipe temperature variations. The approach for the ASAP frost heave analysis is to specify a single longitudinal soil temperature corresponding to thawed soil conditions together with several additional longitudinal soil temperatures to cover the range of frozen soil temperature conditions encountered over a typical year of operation during the frost heave analysis. The longitudinal temperature values and the time between adjacent temperature values are specified for a typical one year analysis cycle. The longitudinal soil temperature will be taken as equal to the pipe temperature which has a seasonal variation that resembles a sine wave.

For ASAP, the thawed longitudinal pipe-soil spring properties are computed using conventional procedures (e.g., see (ASCE 1984), (Hart et. al 2001), and (Honegger et. al 2004)). For frozen soil conditions, the ASAP Project utilizes publically available geotechnical procedures (COLTKBR 2007) for the pipe-soil longitudinal spring relationship.

## 5.5 MODEL GEOMETRY

Detailed two-dimensional pipe-soil interaction analyses have been carried out for thaw settlement induced ground displacement scenarios wherein the assumed ground displacement profiles are basically 'block' downward movements wherein the abruptness of the imposed ground displacement profiles is characterized by 100% of the movement occurring over a very short distance on each end of the block. The block displacement is shown in Figure 20. A factor then representing the difference of ground movement of the settling regime to the adjacent soil segment accounts for the differential movement.

**Figure 20. Thaw Span Block**

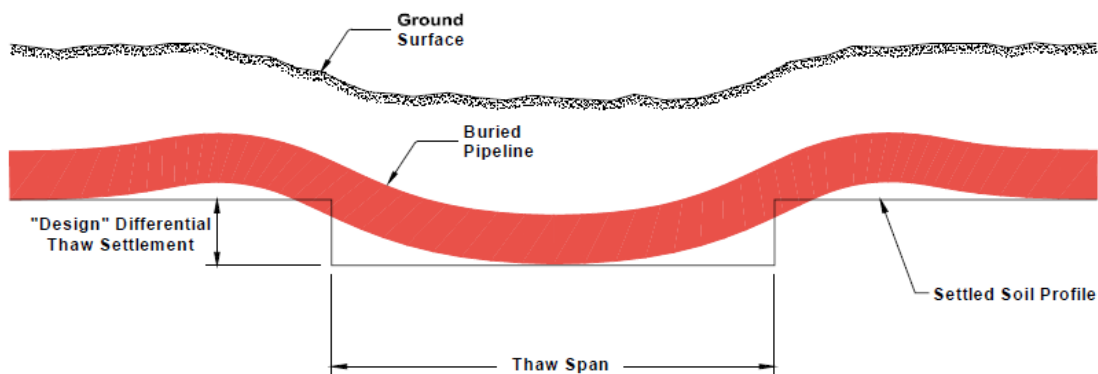

The pipeline is assumed to be running straight and horizontal, and the thaw settlement movement is assumed to occur in the vertical downward direction such that the ground motion and the pipe response occur in the vertical plane. A total of 20 span lengths ranging from 50 feet to 600 feet were considered using PIPLIN's multi-span analysis option (i.e., 50, 60, 70, 80, 90, 100, 110, 120, 130, 140, 150, 160, 170, 180, 190, 200, 250, 300, 400 and 600 feet). For all cases, a plane of symmetry was located at the center of the block ground movement so that only half of the configuration was modeled.

The diameter of the ASAP Mainline is 36 inches with wall thicknesses of 0.527, 0.632, and 0.758 inches, corresponding to design factors of 0.72, 0.60, and 0.50 (Class Location 1, 2, and 3), respectively.

The pipeline is assumed to be buried under uniform cover with assumed cover depths of 3, 5.5, 7.5 and 10 feet. For all these cover depths cases, the water table is assumed to be at the bottom of pipe. PIPLIN's automatic water table loading feature has been utilized for all analysis cases.

Two types of soil properties are considered for the pipe-soil spring calculations: Soil A with bulk density  $\gamma=130$  pcf, soil friction angle  $\phi=32^\circ$  and a cohesion strength of  $c=0$  psf and Soil B with bulk density  $\gamma=130$  pcf, soil friction angle  $\phi=33^\circ$  and a cohesion strength of  $c=100$  psf for all the cover depth cases. Bilinear (elastic-perfectly plastic) pipe-soil springs were calculated for these conditions using PIPLIN's automatic PRCI-2009 procedure.

## 5.6 IMPOSED LOADS

As previously mentioned, differential displacement analyses are typically initiated with the application of gravity, internal pressure and temperature differential loads. If desired, a hydrostatic test loading and unloading sequence can be included prior to applying the operating loads. After the imposition of the operational loads, the detailed analyses for frost heave and thaw settlement are markedly different.

### 5.6.1 Frost Heave

A multi-year frost heave evaluation of the pipe-soil interaction model is then undertaken holding the gravity and internal pressure loads constant. The applied temperature differential can be varied in a sinusoidal pattern over each year of the simulation based on the difference between the time-varying pipe temperature and the constant tie-in temperature. The frost heave analyses are nonlinear time-history analyses performed using small steps through time. Within the heave span, the frost bulb geometry and frost heave vary with time. Seasonal variations of the uplift, longitudinal and creep soil temperatures are specified with each heave time step. The heave is imposed progressively at the base of the pipe-soil springs within the heave span. The amount of heave at the ditch bottom is calculated separately for each transverse pipe-soil support in turn accounting for pressure feedback.

For a selected heave span length, the results from a PIPLIN frost heave analysis include a detailed output of the state of the pipe-soil interaction model at each time step: the uplift, creep and longitudinal soil control temperatures, the longitudinal and transverse spring forces and displacements, the uplift spring displacement rate and the creep displacements for each element of the pipeline model. At the pipe-soil spring locations within the heaving section of the model, the frost bulb width, depth and shear are available together with the pressure components at the base of the frost bulb due to the frost bulb weight, the transverse pipe-soil spring, and shear as well as the total pressure. The current unrestrained mid-span free heave is also provided. The results described above can be post-processed in a number of different ways. Spatial plots and time history plots of various response quantities usually provide the most useful methods for understanding and interpreting the results. It is also possible to develop animations of various spatial response plots

to gain a better understanding of how the overall results vary over the course of the multi-year analysis duration.

### 5.6.2 Thaw settlement

For thaw settlement, typically the maximum temperature differential is applied. The thaw settlement analyses are nonlinear time-history analyses performed using small steps through the displacement increase. The settlement is imposed progressively at the base of the pipe-soil springs within the settlement span. The amount of settlement at the ditch bottom is calculated separately for each transverse pipe-soil support.

### 5.6.3 PIPLIN Output for Pipe Resultants

For a selected displacement span length, the results from a PIPLIN analysis include the pipe axial force, bending moment, hoop stress, top and bottom fiber von Mises stress, longitudinal stress, hoop strain and longitudinal strain and the curvature at each node of the pipeline model.

The results described above can be post-processed in a number of different ways. Spatial plots and incremental history plots of various response quantities usually provide the most useful methods for understanding and interpreting the results. It is also possible to develop animations of various spatial response plots to gain a better understanding of how the overall results vary over the course of the analyses.

The most important results from a simulation for a given span length are the maximum tension and compression strain demands. Detailed processing of the PIPLIN deflected shape at each point in time is used to develop time history plots of ‘digitally pigged’ bending strains or curvatures which provides a basis for relating geometry monitoring data (e.g., smart pig survey data) to the corresponding nodal tension and compression strain demands. A schematic illustration of the maximum pig curvature is presented in Figure 21 for a 25-year frost heave simulation. Note the ‘wiggles’ in the curvature time history plots are due to the seasonal variations in the pipe-soil spring resistance.

Figure 21 can be used to illustrate, on a conceptual basis, the pipeline curvature monitoring approach to be utilized for ASAP for a high displacement location. The dashed yellow horizontal line corresponds to the intervention curvature criterion while dashed red horizontal line corresponds to the curvature associated with the governing pipe strain limit. Note how the intervention threshold is reached in the 13th year of the simulation while the governing strain limit threshold is reached in the 16th year of the simulation.

Figure 21. Illustration of Maximum Curvature Time History

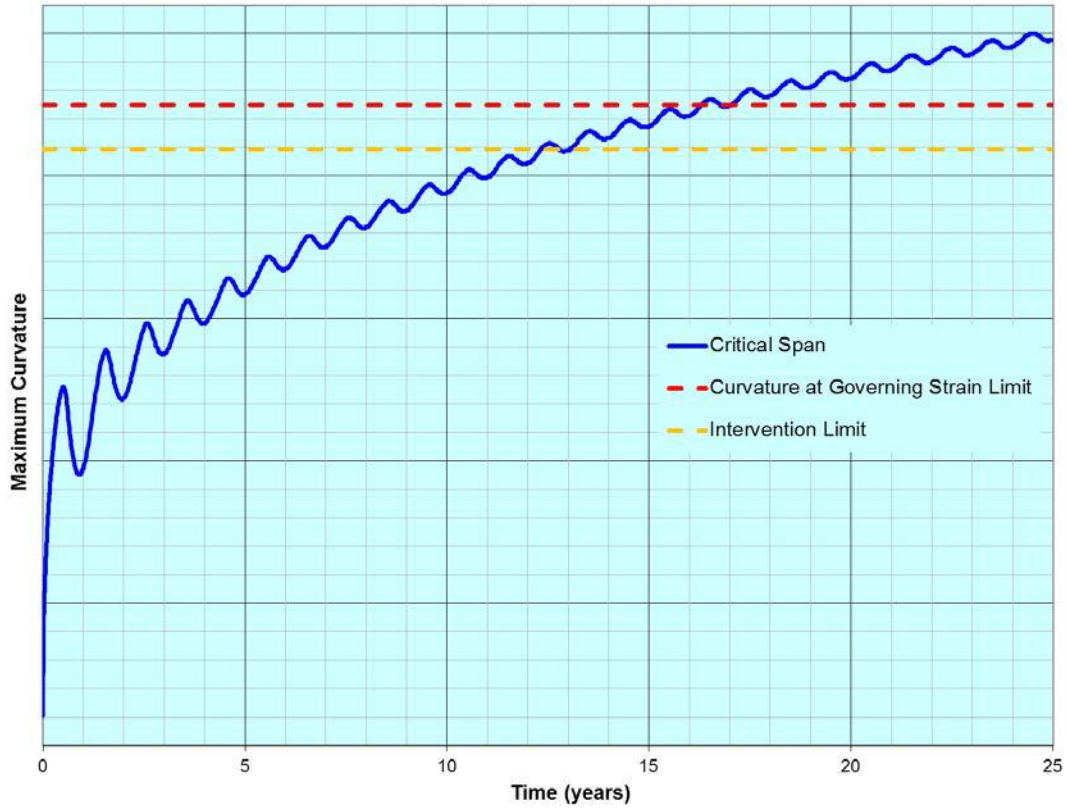

## 6. STRAIN CAPACITY DETERMINATION

### 6.1 MATERIAL REQUIREMENTS

The ASAP will be constructed of API 5L X70 line pipe with a wall thickness that varies between 0.595 inches and 0.857 inches as appropriate for the Location Class (i.e., design factor of 0.72, 0.60, and 0.50 for Class Locations 1, 2, and 3, respectively).

#### 6.1.1 Line Pipe

A generic stress-strain relationship where various properties of the stress vs. strain curve are highlighted is presented in Figure 22. For the purposes of strain demand calculations, the maximum strain range of interest typically runs out to about 2% strain. The initial elastic slope of the curve, frequently called ‘Young’s modulus’ is denoted in Figure 22 as  $E_{\text{start}}$ . The point at which the tangent slope of the curve first departs from a projection of the elastic slope is called the proportional limit. The tangent slope of the curve at high strains (i.e., the slope to the right of the point labeled ‘fully plastic’) is denoted as  $E_{\text{end}}$ . Note the term ‘fully plastic’ is not strictly correct since the steel still has a finite hardening modulus (slope) at this point whereas fully plastic implies a slope of zero. The section of the curve between the proportional limit and the fully plastic point is often referred to as the ‘knee’ region where the steel transitions from elastic to plastic conditions. The dashed line tangent projections from the curve passing through the proportional limit and the fully plastic point (bounding the knee region) make up what is referred to as the backbone curve. For pipe steels, the yield strength is defined as the stress at a strain of 0.5% per API 5L, shown as the stress coordinate denoted as ‘Y’ in Figure 22. Note for nominal pipe size (NPS) 8 and above, the yield strength is defined based on the hoop tension stress-strain curve.

The shape of the pipe steel stress-strain relationship can have a significant effect on the pipe strain demand and as well as the pipe strain capacity (particularly the compressive strain capacity). An illustration of pipe steel stress-strain relationships with different behaviors across the knee region of the curve is presented in Figure 23. In general, pipe steel stress-strain curves with a relatively abrupt or ‘sharp’ elastic-to-plastic transition (purple and red curves) tend to lead to larger strain demands and lower strain capacities than stress-strain curves with a relatively rounded elastic-to-plastic transition (blue curve). Similarly, stress-strain curves with relatively low strain hardening modulus (slope) characteristics (e.g., the red curve in the flat ‘Lüders plateau’ region) tend to lead to larger strain demands and lower strain capacities than stress-strain curves with relatively high strain hardening modulus characteristics. Deformation analyses should consider a range of bounding input steel stress-strain relationships that have been developed to be consistent with exemplar stress-strain test results from the project pipe material.

In addition, the shape of stress-strain curves can be significantly different for pipe steel tests performed in the LT, HT, LC and HC directions, especially for higher grade pipe materials and for UOE pipe. In other words, these materials are anisotropic. Based on experience with UOE pipe test results, it is generally observed that over the strain range from approximately 0.2% to 0.8% strain

(i.e., in the so-called ‘knee’ region), the four stress-strain curves tend to have the following relative strength ranking:  $HT > LC \geq LT > HC$  and the HT curve usually tends to be the ‘sharpest’ of the four curves. Unlike the specifications under API 5L which are focused on the hoop tension yield and ultimate tensile strengths (in order to satisfy the pressure induced hoop stress design requirements), the following sections are focused on the LT stress-strain characteristics.

**Figure 22. Normative Properties of a Steel Stress-Strain Relationship**

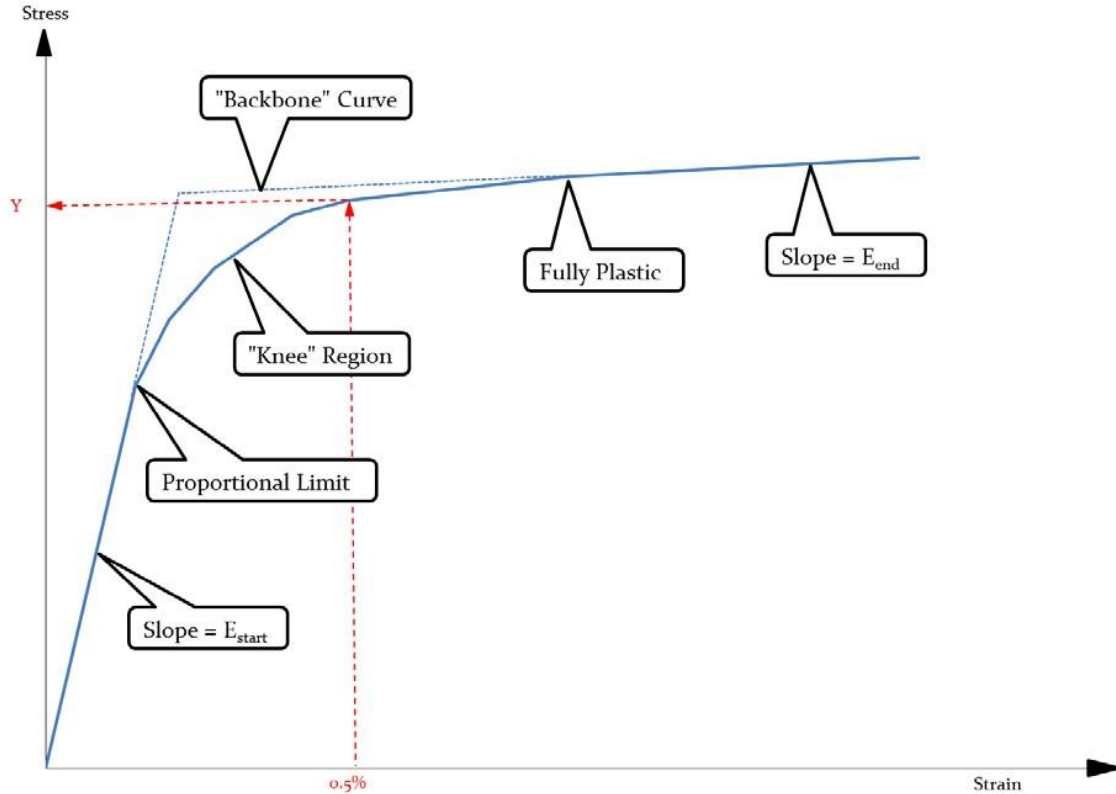
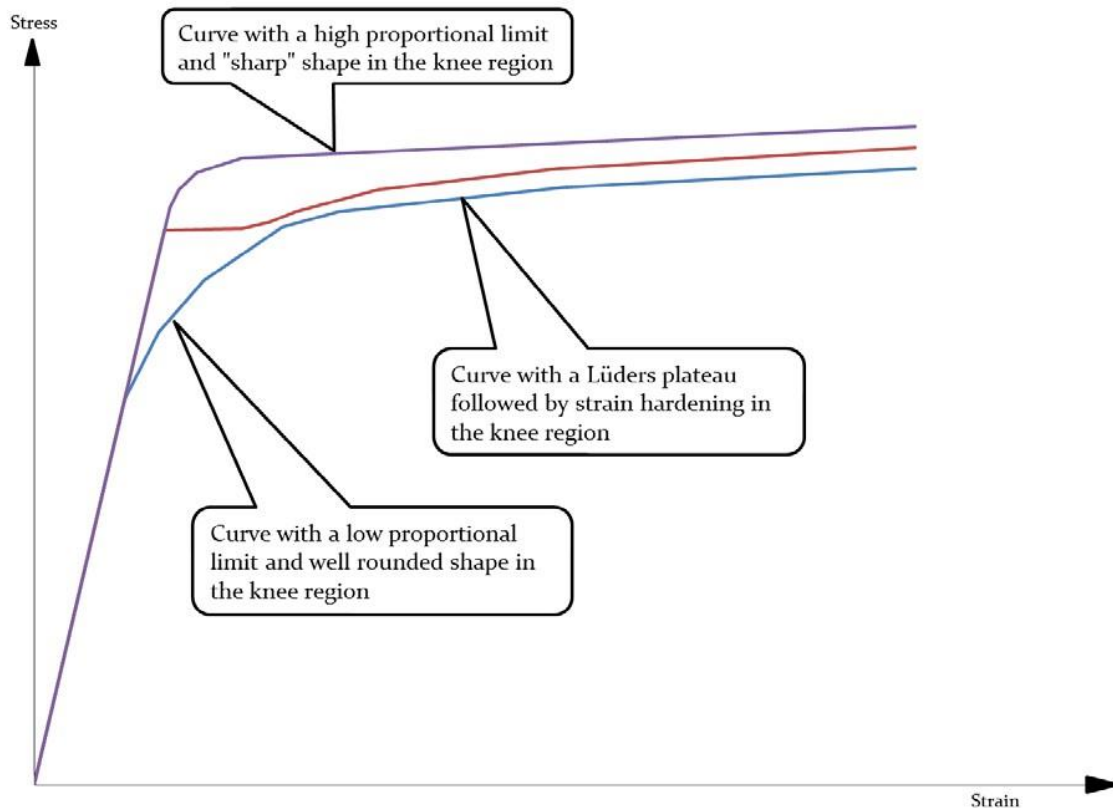

Figure 23. Illustration of Differing Stress-Strain Behavior in the Knee Region



#### 6.1.1.1 Minimum Longitudinal Yield Strength

As noted above, the LT stress-strain curves tend to be slightly weaker than the hoop tension (HT) stress strain curves in the knee region (e.g., in the region where yielding is defined). In many cases, the LT yield stress is actually below the SMYS. This is not normally a cause for concern since as previously noted, the pipe SMYS is defined in the hoop tension direction.

#### 6.1.1.2 Longitudinal Tensile Strength

Consideration will be given to specifying a minimum longitudinal tensile strength, as well as to specifying a relative low yield to tensile ratio to ensure a sufficient work hardening rate to avoid strain localization.

#### 6.1.1.3 Minimum Uniform Longitudinal Elongation

Likewise, consideration will be given to specifying a minimum uniform longitudinal elongation to further avoid strain localization.

#### 6.1.1.4 Longitudinal Stress-Strain Curve

Basic pipe mill certificates will always provide a direct characterization of the yield and ultimate strengths in order to demonstrate the material meets the specified minimum strength requirements. For ASAP, it is anticipated representative fully digital stress- strain curves will be obtained from both the LT and HT directions. It may also be desirable to obtain representative LC stress-strain curves.

Given the digital stress-strain data from representative pipe samples, it will be straight-forward to compute various measures of anisotropy such as the ratio of HT/LT yield and ultimate strengths or strengths at several selected strain levels of interest (e.g., at 1.5%, 2%, etc.). It will also be possible to compute various measures of curve shape or sharpness for the different curve directions such as the ratio of strengths at different levels of strain across the knee region and/or the plastic complementary energy at various levels of strain. These parameters can be used to characterize the variability of the project stress-strain relationships.

#### 6.1.1.5 Lüders Plateau

Localized bands of plastic deformation may occur in certain materials before fracture. These bands are commonly referred to as Lüders bands as they were first reported by Guillaume Piobert and W. Lüders. These localization deformations result in a slight drop in strength below the initial yield strength, which is maintained for a moderate increase in imposed strain. The overall range of formation of the bands may form a flat yield, or Lüders, plateau.

Increasing imposed strain beyond the end of the plateau results in an increase in strength through strain-hardening. Strain-hardening continues to a peak that typically exceeds the yield strength by thirty to sixty percent.

Generally, it is advisable to avoid excessive sharpness in the knee region of the stress-strain curves from any direction (e.g., LT or HT) and also to avoid an excessive Lüders plateau, particularly if SBD applications might be employed. These characteristics can increase the pipe strain demand (while at the same time decreasing the pipe strain capacity).

#### 6.1.2 Coating Effect

Strain aging of pipe (e.g., due to heating during coating application) can tend to increase the sharpness of the knee region particularly for the HT curve with higher temperatures leading to higher levels of sharpness. Strain aging is also known to increase the pipe yield and ultimate strengths. Because strain aging tends to increase the yield strength more than it increases the ultimate tensile strength, it also tends to reduce the strain hardening modulus (i.e., as characterized by the Y/T ratio and/or the slope parameter  $E_{end}$ ) in the region of interest for strain demand. For these reasons, it may be desirable to develop pipe specifications that include review of both as-received and aged stress-strain curves as well as to limit the heat to which the pipe is exposed during coating application if practicable.

### 6.1.3 Dimensional Control

Dimensional imperfections within a single length of line pipe can act as buckle initiation points and need to be minimized. However, the key concern should an SBD be implemented, is variation from pipe to pipe that acts as an imperfection and results in strain concentrations at girth welds. Any aspects of pipe geometry, such as ovality, variations in thickness, or tolerances in pipe diameter, that can result in misalignment across the weld can impact strain capacity. This is particularly true for thicker pipes, where internal or external alignment clamps may not be able to fully 'round out' pipe for welding.

### 6.1.4 Girth Welds

Several welding techniques can be employed on girth welds joining lengths of pipe together. All have some impact on strain capacity. For example, GMAW with low carbon dioxide content shielding gases produces the best combinations of strength and toughness but can be prone to generation of long defects if the welding procedure is not adequately optimized prior to field deployment. It is commonly used for mainline girth welding of long, large diameter pipelines. The various torch configurations such as single torch, dual torch, tandem wire, etc., also have implication on strain capacity. Single torch welding tends to give better results due to the lower heat input, but can affect construction efficiency and pipeline cost, especially in the arctic regions where the construction period is limited and logistics are challenging. Again, a well-balanced approach is needed to select the appropriate welding processes for the double jointing, mainline, tie-in, and infield repair procedures. The requirements of selecting welding procedures for these different types of welds to achieve both high strength and toughness may be challenging. The selected welding processes will need to be properly qualified and tested to confirm the required strain capacity is met reliably.

### 6.1.5 Weld Overmatch

The key difference between welding for typical pipelines and those subject to high strain is the need for substantial and reliable strength overmatch of the weld metal relative to the base pipe. Reliable overmatch is critical for ensuring flaw tolerance adequate to allow for cost effective pipeline construction while ensuring safe design. This has been demonstrated in full-scale pressurized testing, where high weld overmatch was able to prevent failure at a large manufactured defect, resulting in fracture in the pipe body instead of the welds at elevated levels of strain. The level of yield strength overmatch required to ensure a safe design depends on project-specific factors such as pipe grade, pipe geometry, flaw acceptance criteria, and the required strain capacity.

### 6.1.6 Weldment Toughness

Toughness of the weld metal and heat affected zone are critical to strain-based pipeline performance. Upper shelf behavior is required to resist fracture initiation by cleavage. It is also important to ensure adequate upper shelf toughness, which relates to ductile tearing resistance. The Charpy impact test is an excellent tool for assessing toughness and providing a quality check during weld

procedure qualifications but may not be sufficient for the detailed engineering of pipelines anticipated to experience strain magnitudes approaching or exceeding 0.5%. For these applications, fracture mechanics tests, such as the crack tip opening displacement test, should also be used to ensure adequate resistance to fracture with weld imperfections. Achieving high toughness in small scale testing is necessary but not sufficient to ensure a safe and cost effective design if strain magnitudes approaching or exceeding 0.5% are anticipated. The relationship between small scale toughness and full-scale performance at high strain has not been adequately established by industry.

## 6.2 TESTING REQUIREMENTS

A number of small-scale and full-scale tests will be conducted to assist in determining the actual strain capacity of the line pipe to be used on the Project.

### 6.2.1 Curved Wide Plate Testing

Curved Wide Plate Testing (CWPT) has been used by industry as a proof test for qualifying strain capacity for many years. The test specimen consists of a large dog bone shape samples cut from a pipe containing the specific girth weld to be qualified. A flaw is saw-cut or electrical discharge machined into the desired zone of the weld, and the specimen is pulled to failure in tension. Unfortunately, CWPT is not capable of quantifying the effect of biaxial loading due to internal pressure. It is also impractical to use CWPT to evaluate the effect of high-low misalignment on strain capacity. Recent full-scale data have shown these effects on strain capacity can be very significant. However, CWPT is still considered a cost effective and useful test for line pipe and weld procedure qualification and to establish initial estimates of the strain capacity.

### 6.2.2 Full-Scale Tension Testing

Although research is underway to develop suitable alternatives, pressurized full-scale tension testing remains the only fully validated method to confirm tensile strain capacity. If a limited number of tests are planned, an effective strategy is to use these tests to examine lower bound behavior. The goal is to confirm the design meets the strain demand requirement when the key parameters are at the extremes of the acceptable construction envelope. Care should be taken to select test samples representative of the worst expected combination of the key fabrication parameters. On the other hand, selecting overly conservative parameters can result in an undesirable outcome. Another consideration is the availability of test frames to conduct these full-scale tests. Industry has developed and validated empirical equations and finite element modeling methods for estimating the tensile strain capacity of pipelines and these tools will be used in conjunction with the full-scale tests to validate the design.

### 6.2.3 Compressive Strain Validation

Industry has developed and validated empirical equations and finite element modeling methods for estimating the compressive strain capacity of pipelines. The most widely used measure of pipe compressive strain capacity is that associated with the peak moment from an imposed curvature

test on a full-scale pipe specimen or finite element analysis (FEA) of a pipe stub section. Note this strain limit is a serviceability limit state with a significant post-wrinkling reserve margin before the pipe pressure integrity is compromised (usually due to the development of high local strains within the wrinkle(s)). Empirical equations of this sort will be used to establish preliminary pipeline compressive strain capacity. FEA and possibly pressurized full-scale bend tests, will be conducted to establish the compressive strain capacity. These studies will account for the effects of pipe anisotropy, material work hardening characteristics, girth weld misalignment or high-low, internal pressure fluctuations, axial loading, and thermal aging. The FEA method will be the primary tool to quantify the effect of variability in all major parameters; full-scale bend or buckling tests will only be used to validate the finite element models and provide useful experimental design data, if deemed necessary. A large number of FEAs may be required to cover a full range of parametric studies in support of a design reliability assessment. Because the compressive strain is defined over a certain gauge length (typically one to two pipe diameters), the selection of gauge length will accommodate geometric deformation effect and ensure the practical strain detectability by ILI tools. A common gauge length in finite element compressive strain capacity assessment, strain demand assessment, operation ILI monitoring, and any full-scale bend tests will be used.

## 7. ROUTE APPLICATION

### 7.1 GENERAL OVERVIEW

ASAP is using a methodical approach in identifying, characterizing, evaluating, designing for, and mitigating time dependent route geohazards. In the case of frozen and unfrozen ground challenges, ASAP is using a stepped approach to develop data for use in engineering design to reduce or mitigate the effects of these geohazards on the pipeline. These basic steps are summarized below and described in more detail in the following sections.

- Geologists conducted mapping of Terrain Units in plan view using data from the following sources:
  - a. Aerial photography/orthorectified (geometrically corrected) imagery (approximately 3,733 square miles), and satellite imagery
  - b. Topographic mapping, Light Detection and Ranging (LiDAR) imaging from which digital elevation models (DEM) were developed (approximately 2,079 square miles)
  - c. Surficial and bedrock geology maps from public domain
  - d. Geotechnical borehole drilling and sampling; soil and rock laboratory testing from over 10,000 discrete boreholes
  - e. Installation/monitoring of ground temperature and water table instrumentation
  - f. Results of hydrology surveys
  - g. Ground truthing by field reconnaissance geologists (field trip reports)
- Terrain units may consist of multiple landforms in plan (mosaic terrain unit) or in layers. The depth or thickness of these landforms are generally described down to 20 feet bgs. Two dimensional geological cross sections or 3D fence diagrams can then be created using heritage and recent ASAP borehole and test pit data.
- Engineering data such as visual soil descriptions, soils laboratory data, ground temperature measurements, and groundwater depth measurements are then related to specific landforms and terrain units. These are documented in the ASAP geotechnical database library for use in further engineering analysis. A GIS geospatial database is used to illustrate terrain units, borehole locations, LiDAR, orthoimagery, and other data pertinent to the pipeline corridor. The GIS forms an integral part of the geohazard identification, evaluation and avoidance of pipeline route hazards in the design process.
- Geohazard Evaluation and Mitigation Analysis Reports covering topics such as Hydrotechnics, Soil Geochemistry, Unique Soil Structure, Surface Fault Rupture, Tectonics and Seismicity, Landslides (slope stability), Erosion and Buoyancy, Freezing of Thawed Soils and Thawing of Frozen Soils have also been acquired by ASAP.
- All data used for design and all analyses have been subjected to rigorous expert review both external and internal to the ASAP Project.

## 7.2 GEOTECHNICAL PROGRAM

The ASAP borehole drilling program was developed to validate TU mapping and provide subsurface data to the project engineers, geotechnical specialists, and construction planners. To date, ASAP has drilled over 800 boreholes. The individual hole locations were selected for different reasons: terrain unit validation based on aerial photography and LiDAR hillshade images, for determining subsurface locations for specific structures or horizontal directional drilling (HDD)'s, geochemical information for input in to the cathodic protection (CP) design, material site development, or volume quantification, etc. The desired depth of a typical borehole is 50 feet; HDD boreholes or CP boreholes may have desired depths of more than 300 feet, the actual depth of the drilled borehole may be nowhere near the desired depth based on in situ drilling conditions which would cause the driller to stop drilling. Soil samples are taken at different intervals based on the reason for the hole, and laboratory analysis is done on the soil samples. Different laboratory test, such as soil resistivity, moisture content, bulk density, particle size distribution, Atterberg limits, etc., are selected based on the reason for the borehole.

Regardless of the borehole location, depth, number of samples, or laboratory tests, all of the borehole data is entered into the project borehole database. In addition to the ASAP boreholes, the borehole database includes borehole data for over 12,000 boreholes from public and private sources. All of the drilled and collected borehole data is used to better characterize the subsurface conditions along the alignment.

## 7.3 THAW SETTLEMENT

### 7.3.1 Design Approach and Analysis

The potential for thawing of frozen ground below the pipeline has received special consideration in accordance with the *Design Basis – Pipeline* (ASAP-27-BDC-YYY-DOC-00015, Michael Baker, Jr. 2015). Under Section 3.2.1.2 of the *Design Basis*:

*The approach to thaw settlement analysis is to couple route soils data with climatic data and pipeline thermal prediction. Pipeline thermal conditions are predicted using the hydraulics model described in Section 2.1 (of the Design Basis), Pipeline Hydraulics. The hydraulics model predicts temperatures along the pipeline for a given throughput and inlet temperature and pressure, initial soil conditions, and gas properties shown in Table 1 (of the Design Basis), Design Gas Composition. The pressure and temperature of the flowing gas depends upon the heat flux through the pipe wall which, in turn, depends on the pipe inter-action with the subsurface thermal state.*

*The temperature results from the pipeline hydraulics are then input into a 2-dimensional geothermal model. The 2-dimensional FEA is used to find the subsurface thermal conditions at various locations based on the combined effects of surface climatic variations and pipe wall temperature as defined by the hydraulics model. The output will be a series of 'snapshots' along the pipeline of the changing thermal condition of the subsurface over*

*time. The final outcome is an estimate of the magnitude and timing of thawing of initially frozen ground.*

The purpose of this section is to introduce the design methodology for assessing the pipeline response to potential threats related to thaw settlement in areas where the ASAP is routed through thaw unstable soils. Specifically, this section introduces the ASAP approach employed to ensure pipeline mechanical/structural integrity when subjected to potential displacements associated with earth movement due to thaw settlement.

A schematic illustration of a thaw settlement scenario is presented in Figure 15 and Figure 18. Thaw settlement occurs when ice-rich frozen soil below the pipe thaws, and any thaw unstable soil consolidates resulting in vertical downward displacement. Several sources may contribute to the soil thawing including; right-of-way clearing, construction grading, and operation of a relatively warm buried pipeline. As the soil progressively thaws, downward settlement of the pipe is produced by thawing of frozen soil in which it is buried, and consolidation of this thawed material. The gravity and soil down drag loads pull the pipe downward as bearing support is reduced by settlement. The amount of consolidation produced by a given increase in thaw depth can be affected by the type of soil, the absence or presence of ice lenses and other factors. The depth of thaw does not necessarily correlate with the depth of settlement, non-thaw susceptible soils (clean gravels) may not settle much at all, but thaw susceptible soils (i.e. ice rich, high silt content) will have higher settlement.

Significant pipe stresses and deformations can occur when the buried pipeline runs between a thaw-stable soil and a thaw-unstable soil, or two lateral extents of thaw unstable soil with differing magnitudes of consolidation. As ice-rich soil in a thaw unstable soil section thaws, it consolidates and the pipe settles, while the pipe remains stationary or settles less in the adjacent soil section. This results in a differential vertical displacement (or settlement) profile across the transition between the two soil sections. The differential settlement can result in significant pipe strains due to pipe curvature and axial force effects. Figure 24 presents an example of thaw potential with various surface cover over time at the CRREL Test Site in Fairbanks (Figure 25).

Figure 24. Thaw Potential with Various Surface Cover (CRREL)

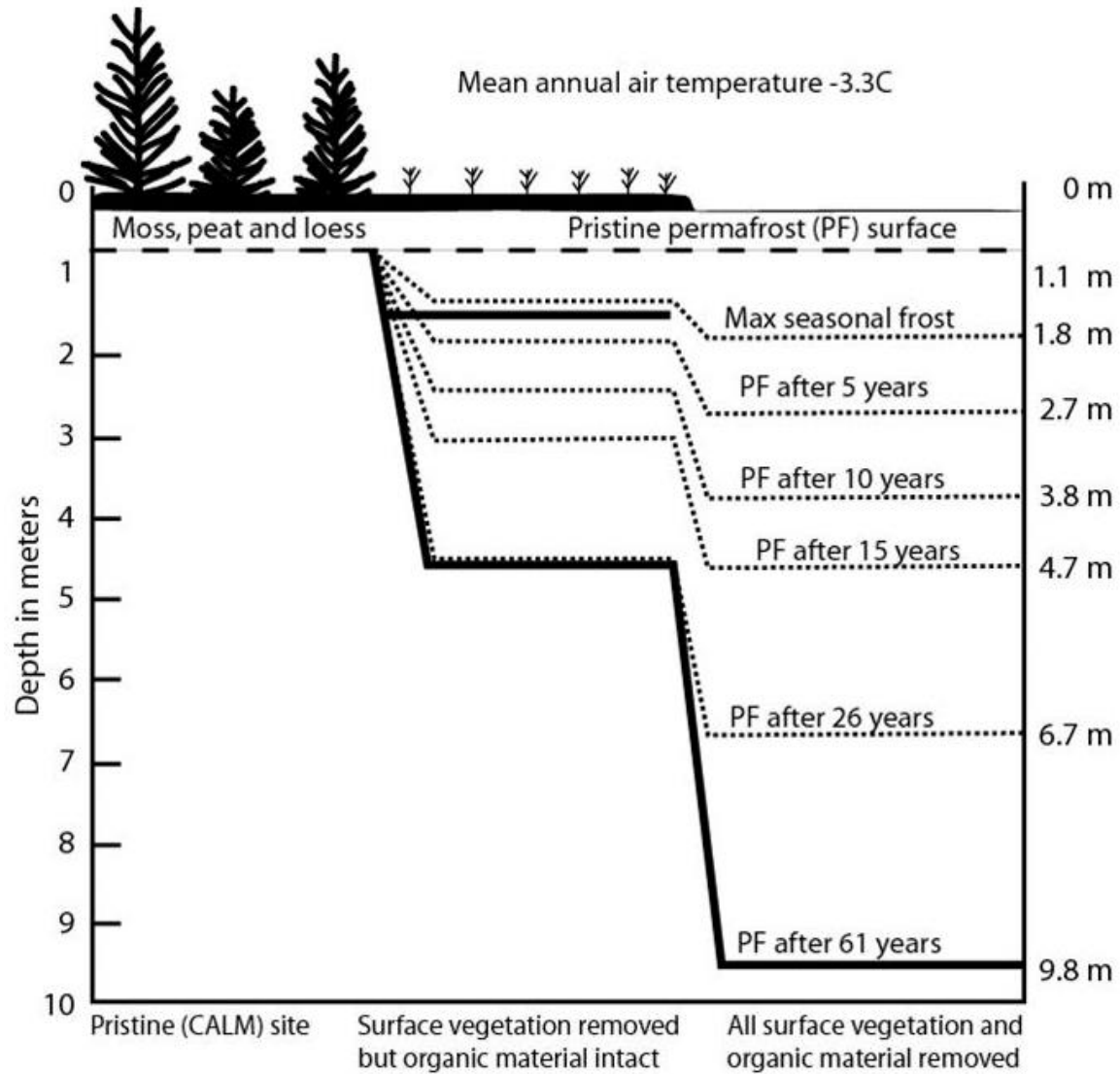

Figure 25. CRREL Site in Fairbanks Alaska



The general process for quantifying thaw settlement potential for the route soils consists of the following steps:

- Group geotechnical borehole data by Terrain Unit/Climatic Zone.
- Develop thaw strain values for each borehole using results of thaw consolidation tests or appropriate correlation equations.

A geotechnical borehole database incorporates project-specific data and heritage data along the alignment corridor acquired by the project. This database is used to correlate geotechnical soil properties to terrain unit/climatic zone combinations as appropriate for further analysis, and to retain engineering data derived from the correlations for route assessments.

If frozen soil has moisture content in excess of what can be stored within its pore spaces, it is prone to settlement upon thaw. The amount of strain (or settlement) that can occur is a function of both

the type of soil and its moisture content. In the laboratory, thaw strain is determined by thaw consolidation tests. In such a test, a sample of frozen soil is allowed to thaw in a triaxial or oedometer apparatus and the changes in sample height recorded. The total magnitude of thaw settlement is the summation of the individual thaw strains of each soil layer within the zone of thaw penetration.

Thaw strain can be empirically correlated with either initial frozen bulk density or moisture content of a soil sample. Early research into the thaw settlement phenomena focused on thaw strain — frozen bulk density correlations. However, because frozen bulk density information is difficult to obtain and requires undisturbed samples, frozen bulk density information is generally rarely available. In contrast, unfrozen moisture content data is generally readily available, and hence is a better choice for developing thaw strain correlations for this project.

Natural moisture content is normally reported gravimetrically as the ratio of the weight of water to the dry weight of solids. This definition is suitable for most non-permafrost soils. Hence it is used worldwide and is the parameter generally reported. However, in very ice-rich permafrost soils, gravimetric moisture contents trend towards infinity, making it difficult to establish thaw strain correlations that also have theoretical bounds. This difficulty can be overcome by considering volumetric instead of gravimetric moisture content (i.e., the volume of water relative to the total volume of the sample).

A number of geothermal heat transfer analyses were conducted to determine the depths of thaw for terrain unit/climatic zone combinations encountered along the pipeline alignment. The effect of the operational pipe is included if the presence of the pipe would have an appreciable impact on the thaw depth. Under the current lean gas concept, the pipeline temperature is expected to operate near ambient conditions. As such, the actual steel pipeline induced effect on the ground temperature should be minimal; however, the surface clearing and trench construction will have an effect on the thermal conditions.

Individual boreholes within the database will be evaluated for potential thaw settlement. The primary analysis tool for evaluating the effects of thaw settlement on the ASAP pipelines is PIPLIN (SSD Inc. 2012), a special-purpose program developed to perform stress and deformation analysis of two-dimensional pipeline systems. The program considers several nonlinear aspects of pipeline behavior, including pipe yield, large-displacement effects, and nonlinear soil support.

The analyses are initiated with the application of gravity, internal pressure and temperature differential loads. A thaw settlement evaluation of the pipe-soil interaction model is then undertaken holding the gravity, internal pressure and temperature differential loads constant. The thaw settlement analyses are performed as simple settlement profile evaluations with no time or temperature dependent pipe-soil spring parameters. A settlement profile is specified at the base of the pipe-soil springs. The simplest assumption for a settlement profile is a 'block' movement over a selected span length with a very short transition length between the thaw stable and thaw unstable soil regions. A transition length or ramp between the finite length section of thawing/settling soil and the adjacent thaw stable soil section can also be specified. More complicated settlement profiles can

also be specified such as pro-files based on LiDAR measurements or artificially generated profiles consistent with observed measurements (Nixon et al. 2010).

To complete the design evaluation, the pipe strain demand levels must be compared to allowable levels of the corresponding pipe strain capacity.

### 7.3.2 Segment by Segment Design

Terrain units are used to identify areas of similar geomorphological origin, in order to develop a model of soil conditions along the pipeline. Terrain unit mapping along the v6 alignment was initially conducted in 2013. The terrain unit mapping defines areas that underwent similar geomorphological processes and are comprised of various landforms.

Each terrain unit may be defined as a simple terrain unit (consisting of a single landform), a layered terrain unit (consisting of a landform greater than three feet thick overlying an older landform), a mosaic terrain unit (consisting of two surface landforms, with the aerially dominant landform first), and a complex terrain unit (consisting of a combination of two or more terrain units). The terrain units are considered representative of the soil or rock conditions within approximately 20 feet of the ground surface. An example of terrain unit mapping is shown in Figure 26. A borehole log associated with the terrain unit mapping in Figure 26 is shown in Figure 27 (continues across two pages).

The terrain unit mapping is largely based on expert review of aerial photography, vegetative cover, and local knowledge of the geologic development of the terrain features. The language used in the Terrain Unit lexicon underscores this – for example, the designation ‘GL’ for a landform within a terrain unit indicates the depositional development is largely governed by glacial lacustrine morphology, or that ‘O’ is largely organics. These individual units, called ‘Landforms’ can then be ‘stacked’ to build a composite picture of the subsurface – for example ‘O/GL/BX’ would mean an Organic layer overlays a glacial lacustrine layer which in turn overlays the bedrock (BX). The composite development of Landforms (‘Terrain Units’) is the basic building block of the route characterization.

However, additional insight into the layering must be developed for engineering use. For example, the designation ‘O/GL/Bx’ does not relate the strata layering thicknesses of the individual Landforms nor the associated soil index properties (e.g. moisture content, dry density...) to use in engineering formulations. For this further engineering data development, review of individual boreholes, and the soil laboratory analysis of the samples recovered from the boreholes, is used. The strata recorded during the field borehole program provides the basis for the understanding of the subsurface strata layering. Laboratory analysis of the individual samples recovered from the various layered strata from the borehole are further used to define the soil index properties for the subsurface strata. Since there is variability in the laboratory data, geostatistics are used to define the range of engineering data and conservative selections are used in further engineering analysis.

Figure 26. Terrain Unit Map



Figure 27. Typical Borehole Log

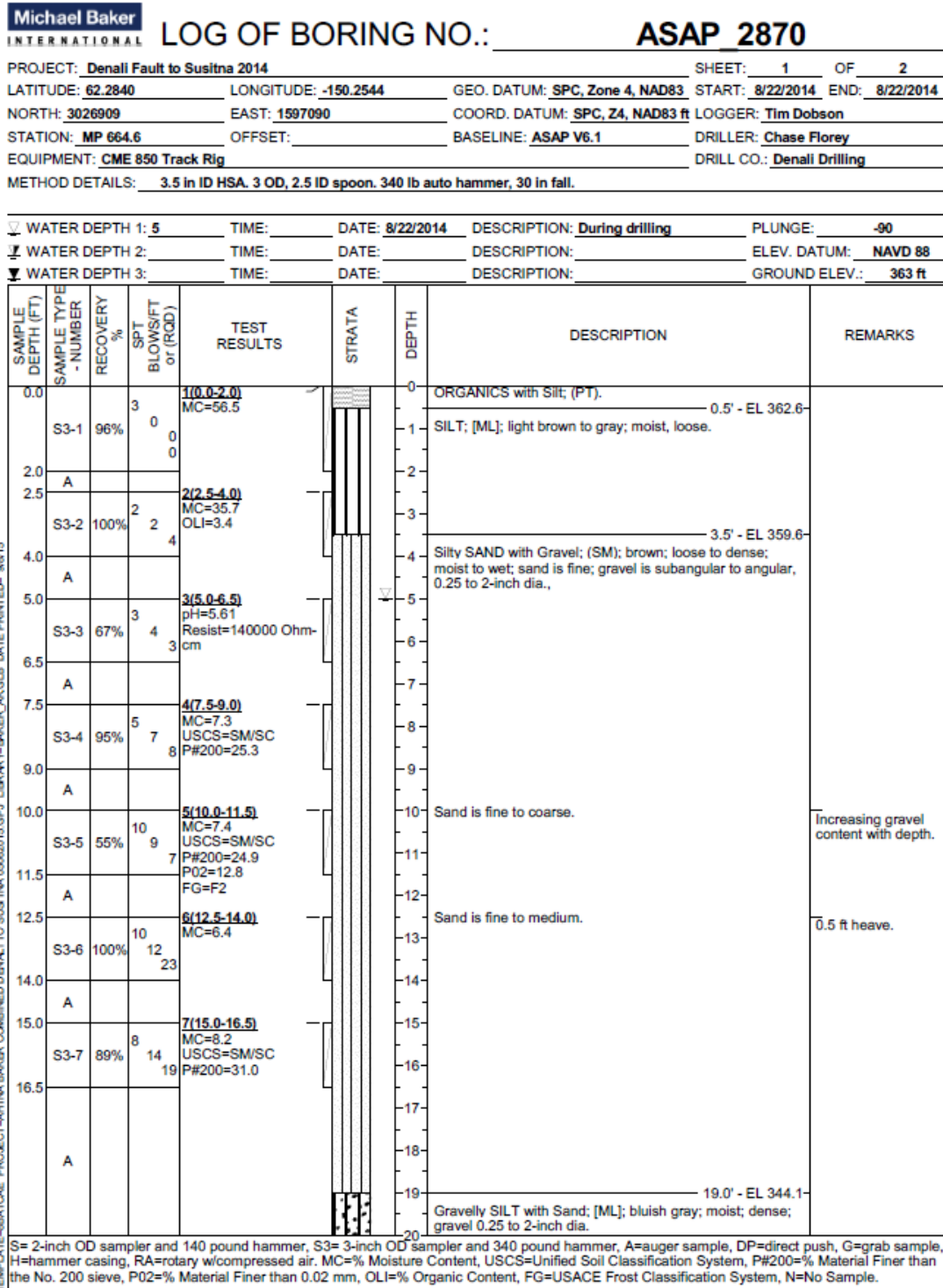

## Typical Borehole Log Continued

**Michael Baker INTERNATIONAL** LOG OF BORING NO.: **ASAP 2870**

PROJECT: **Denali Fault to Susitna 2014** SHEET: **2** OF **2**

LATITUDE: **62.2840** LONGITUDE: **-150.2544** GEO. DATUM: **SPC, Zone 4, NAD83** START: **8/22/2014** END: **8/22/2014**

NORTH: **3026909** EAST: **1597090** COORD. DATUM: **SPC, Z4, NAD83 ft** LOGGER: **Tim Dobson**

STATION: **MP 664.6** OFFSET: \_\_\_\_\_ BASELINE: **ASAP V6.1** DRILLER: **Chase Florey**

EQUIPMENT: **CME 850 Track Rig** DRILL CO.: **Denali Drilling**

METHOD DETAILS: **3.5 in ID HSA, 3 OD, 2.5 ID spoon, 340 lb auto hammer, 30 in fall.**

✓ WATER DEPTH 1: **5** TIME: \_\_\_\_\_ DATE: **8/22/2014** DESCRIPTION: **During drilling** PLUNGE: **-90**

✗ WATER DEPTH 2: \_\_\_\_\_ TIME: \_\_\_\_\_ DATE: \_\_\_\_\_ DESCRIPTION: \_\_\_\_\_ ELEV. DATUM: **NAVD 88**

✗ WATER DEPTH 3: \_\_\_\_\_ TIME: \_\_\_\_\_ DATE: \_\_\_\_\_ DESCRIPTION: \_\_\_\_\_ GROUND ELEV.: **363 ft**

SAMPLE DEPTH (FT)	SAMPLE TYPE - NUMBER	RECOVERY %	SPT BLOWS/FT or (ROD)	TEST RESULTS	STRATA	DEPTH	DESCRIPTION	REMARKS
20.0 20.2	S3-8	100%	30/3*	8(20.0-20.5) MC=8.9	[Patterned Strata]	20	Gravelly SILT with Sand; [ML]; bluish gray; moist; dense; gravel 0.25 to 2-inch dia.	0.2 ft cobble fraction observed in sampler shoe
	A					21 22 23 24		
25.0 26.5	S3-9	67%	10 16 13	9(25.0-26.5) MC=7.8		25 26		
						26.5'	26.5' - EL 336.6'	
						27	Bottom of Boring 26.5 ft.	
						28	Boring Completed 8/22/2014.	
						29	Boring backfilled with cuttings.	
						30		
						31		
						32		
						33		
						34		
						35		
						36		
						37		
						38		
						39		
						40		

TEMPLATE=SBATCAE PROJECT=AHNA BAKER COMBINED DENALI TO SUSITNA 05/06/2015.GPJ LIBRARY=BAKER\_AK.GLB DATE PRINTED= 8/15

S= 2-inch OD sampler and 140 pound hammer, S3= 3-inch OD sampler and 340 pound hammer, A=auger sample, DP=direct push, G=grab sample, H=hammer casing, RA=rotary w/compressed air. MC=% Moisture Content, USCS=Unified Soil Classification System, P#200=% Material Finer than the No. 200 sieve, P02=% Material Finer than 0.02 mm, OLI=% Organic Content, FG=USACE Frost Classification System, N=No Sample.

Geostatistics have been used to identify moisture content, soil type, and assume unit weight values for the various landforms to support the preliminary thermal modelling. For the analysis performed for the Class III estimate, these values were based on assumed thickness of the upper and lower landforms of the primary terrain unit based on the ASAP geotechnical boreholes and laboratory testing available.

Based on the terrain unit descriptions and anticipated geomorphological conditions, a preliminary Unified Soil Classification System (USCS) representing the soils below the pipeline was identified. In cases where one landform was overlying an older landform, the older landform was assumed. In areas where there was a mosaic terrain unit, the dominant landform was assumed.

ASAP Project used the Permafrost Characteristics of Alaska (Jorgenson et al. 2008) to identify zones of continuous, discontinuous, sporadic, and isolated permafrost along the alignment.

For the purposes of providing a preliminary thermal state, areas along the alignment identified as continuous and discontinuous were assumed to be frozen and those areas identified as sporadic and isolated were assumed not to have permafrost. The thermal state was then modified based on the results of historical ADOT&PF and AGDC borings and specific terrain unit descriptions.

Based on the terrain units and soil types, the soils were generally grouped into four types: gravel, sand, silt, and peat. For thermal analysis purposes, weathered rock and rock were identified as gravel; however, significant thaw settlement is not anticipated in areas identified as rock. Organics were classified as peat.

In the 1980s, the Northwest Alaskan Pipeline Company (NWA) developed a climate set based on the data available at the time. They used a climate zone method, dividing their pipeline alignment into eight zones with approximately the same characteristics. The northernmost six climatic zones overlap the ASAP alignment. Where the NWA and ASAP alignments diverged, three new climate zones following similar reasoning were developed. While more robust climate data sets are currently available facilitating mile-by-mile analyses, the zone concept provides a practical screening level of effort.

Ground temperature simulations apply surface and bottom boundary conditions for temperature and heat flow. The top, surface boundary primarily uses the climate-based annual air temperatures. These air temperatures are modified by an N-factor that accounts for various surface types such as bare earth, gravel, tundra organic mat, forest, and snow. The bottom, subsurface boundary typically replicates the conditions at a point underground where thermal conditions are naturally stable, typically ranging from 50 to 100 feet below the surface. Where available, actual subsurface temperatures measured in soil borings are used. Alternatively, a nominal heat flow representing the energy upwelling from the earth's core is applied to the bottom boundary.

### 7.3.3 Thermal Simulations

The estimated thaw settlement below the pipeline was calculated by summing the thaw settlement in the upper layer below the base of the pipe and the settlement in the lower layer. For the preliminary analysis, it was assumed the lower soil type (if present) was encountered at a depth of 10 feet and the bottom of the pipe was 8.5 feet bgs. For each soil layer (or single soil layer, as appropriate), dry density values were assumed. The anticipated strain was then calculated using the regression curves presented in Nelson et al. (1983) for the appropriate soil type. For areas of weathered rock and bedrock, thaw settlement was assumed to be zero.

- Potential thaw settlement below the pipe and within the top 10ft was calculated as the product of the strain (determined according to Nelson) and the minimum value of the depth below the pipe thaw occurs or 1.5 feet (the bottom of the upper soil layer). Thaw settlement in the lower layer was calculated by multiplying the strain rate of the lower layer and the positive difference between the depth of thaw and 10 feet.
- A spreadsheet was developed to calculate these quantities along the alignment. Based on the calculated thaw settlement, the required pipeline wall thickness was selected.

The TEMP/W module of the commercial modeling software GeoStudio 2012 from GEO-SLOPE International, Ltd. was used to perform the ground temperature analyses. TEMP/W is a two dimensional, transient program which accounts for frozen and unfrozen material properties and latent heat effects. Finite element schemes divide the material being analyzed into many small pieces (elements) and employ Fourier's Law of heat conduction between the elements. An analysis is performed by advancing time steps and the heat flow and new temperatures are computed at each step. These simulations have the advantage of:

- Varying the boundary conditions as the simulation steps forward
- Returning the temperature at points within the material
- Accounting for latent heat of fusion
- Changing the material properties during the simulation

### 7.3.4 Thaw Settlement Methodology

In geotechnical engineering, settlement can be caused by several mechanisms:

- Elastic deflection: The soil behaves as a spring, compressing under load, but recovering when the load is removed.
- Compaction: The soil particles are loose and compress to a greater density state under the load.
- Consolidation: This is usually a long-term effect in fine-grained soils (silts and clays) where the soil compresses slowly as porewater is squeezed out and the soil fabric readjusts to the load.
- Thaw settlement: This occurs when interstitial (pore) ice melts and the soil particles 'fall' together.

Of the four settlement mechanisms, thaw settlement causes the preponderance of pipe deflection in arctic regions. When ice rich ground is in the permafrost state, it has high strength. When it warms sufficiently the ice melts, the soil grains collapse until they touch and establish a soil skeleton. The associated settlement is in proportion to the amount of excess ice.

In a similar manner to the thermal analysis, representative soils were chosen for the settlement analysis. These were chosen according to standard properties in the USCS. The USCS defined soil types are widely used in soil boring descriptions and most civil engineering practice. They provide a link from geologic-based landform to engineering application. Based on the depth of thaw determined by geothermal modeling, thaw settlement was calculated using the thaw strain prediction equation presented by Nelson et al. (1983).

The thaw settlements are calculated on two general sources of data, namely the model-predicted thaw depths, and the thaw strains for various landform-types based on thaw strain data from bore-holes. In a spreadsheet, the thaw strain was calculated terrain unit-by-terrain unit for the length of the pipeline.

### 7.3.5 Potential Design Mitigative Measures for Thaw Settlement

Dividing lines between terrain units present the greatest potential for pipeline design challenges. For example, where a pipeline segment transitions from a bedrock landform to an ice-rich silt landform, there could be large differential settlements, which cause associated pipe bending stress. Where identified, possible methods of controlling the settlement include:

- Make minor changes in alignment to avoid high differential settlement areas
- Investigate the subsurface of the suspect terrain segment more closely so as to reduce the conservatism inherent in the station to station approach
- Specify pipe properties to handle the bending force within allowable limits
- Over-excavate the trench and backfill with clean granular soil to reduce total settlement
- Specify special heat control finishing such as insulation and ground cover
- Consider use of passive refrigeration for localized thaw settlement areas
- Combine compatible concepts provided above

The uncertainty associated with the location and distribution of massive ice limits the potential for advance mitigation of this hazard. Areas of massive ice can be excavated during pipeline construction or pre-thawed and consolidated in advance of pipeline construction. Additional passive thermal stabilization techniques can be used to reduce the potential for the ice to thaw. Avoiding landforms associated with massive ice by route refinement may be an option in some areas.

## 7.4 FROST HEAVE

### 7.4.1 Design Approach

The purpose of this section is to introduce the design methodology for addressing potential threats related to frost heave in areas where ASAP is routed through frost susceptible soils.

Frost heave occurs when a chilled pipeline freezes water in frost-susceptible soil in which it is buried. As the soil freezes, it expands and forms a frost bulb around the pipe. Upward heave of the pipe is produced by swelling at the bulb face as the bulb grows. Significant pipe stresses and deformations can occur when the buried pipeline runs between a stable soil and a frost-susceptible soil. Because the pipe heaves in the frost-susceptible soil section but remains stationary in the adjacent stable soil section, a differential vertical heave displacement profile is produced across the transition between the stable and frost-susceptible soil sections.

In general though, for frost heave or frost jacking to be a hazard to pipeline operations, three conditions must exist simultaneously:

- Climatic conditions and/or pipeline operations chill the ground causing a phase change near the pipeline.
- Frost susceptible soil in the freezing zone near the pipeline.
- Sufficient moisture and moisture migration to form massive ice upon freezing.

The basic approach for evaluating this geohazard was to assess each of these conditions to determine if freezing of unfrozen ground could have an adverse impact on ASAP. If frost heave beneath ASAP is found to be a credible hazard, then a subsequent step is needed to assess the pipeline soil interaction (displacement, stress, and strain, etc.) for pipeline design.

A number of approaches can be used, ranging from a relatively simple and straightforward deterministic design approach, where estimates of the strain demand and strain capacity are compared, to more elaborate methods that consider the probability of failure or the reliability of the pipeline.

For the ASAP, a deterministic design approach will be utilized and materials that have strain capacity well in excess of the maximum expected strain demand will be selected. All of the parameters used in determining either strain demand or capacity will be conservatively selected. An appropriate safety margin between the conservatively estimated demand and capacity will be applied. The margin will be determined based on the uncertainty level of the key parameters used in ascertaining the design values.

Geothermal design considers the coupled effect of soil mechanics and heat transfer principles that drive physical processes that can impact the operational reliability and performance of the pipeline. Examples of these processes are:

- Frost bulb formation

- Frost heave beneath the pipe

In general, the pipeline will be operating at ambient ground temperature in the continuous and discontinuous permafrost regions. As a result, frost heave is unlikely in unfrozen frost-susceptible soils where the pipeline operating temperature is below freezing. Frost heave is anticipated where unfrozen frost-susceptible soils exist in combination with other critical conditions such as available water.

Geotechnical/geothermal data will be used for general and specific geotechnical analysis for the gas pipeline. The following data have been gathered and are available to the Project:

- Soils, thermal state, and groundwater data from heritage boreholes and from test pit logs and boreholes drilled by the project.
- Laboratory data from index property and engineering property tests done on borehole and field samples acquired by the project.
- General and specific geological and geotechnical data from published sources
- Orthoimagery and other aerial or satellite based imagery acquired for the project.
- Topographic data from project field survey work, LiDAR, aerial photography, and published maps.
- Bedrock data from borehole logs, laboratory testing of samples, field reconnaissance, and available public sources.
- Terrain unit and landform data developed by the project and from published maps and reports.
- General reconnaissance data from field programs.

Several datasets were used in the evaluation of the freezing soils geohazard along the alignment. In order to develop a model of the soil conditions along the pipeline, terrain units are used to identify areas of similar geomorphological origin. The terrain unit mapping defines areas that underwent similar geomorphological processes and are comprised of various landforms. The terrain units are considered representative of the soil or rock conditions within approximately 20 feet of the ground surface. Terrain unit classifications were correlated to simplified soil types for which soil properties could be assigned based on statistical analysis of the project geotechnical database. These soil properties, along with winter and summer ground temperatures at a depth of five feet were input into pipeline modeling software to determine seasonal pipeline operating temperatures.

The ASAP geotechnical database includes frost classification of soil samples collected in boreholes drilled to characterize the pipeline route. Soils with frost susceptible lab results were used to identify or screen the landforms along the alignment having the potential to support a frost heave hazard. Additional testing of frost segregation potential was conducted for ASAP to provide a quantitative means for calculating frost heave displacement where frost heave is determined to be a credible hazard. The project geodatabase was then used to identify boreholes and laboratory samples having a frost susceptibility classification of F3 or F4.

Simplified geothermal analyses were conducted to estimate the rate of growth and maximum extent of the freezing zone around a pipe utilizing TEMP/W. For these analyses soil properties, pipeline operating temperatures, surface temperatures, and geothermal heat flux values were input.

#### 7.4.2 Design Parameters

Geotechnical parameters necessary for frost heave analysis and design were initially estimated based on terrain unit analyses already completed and calibrated against legacy borehole and lab test data recovered for the project. Frost susceptibility is primarily a function of soil grain size where non-plastic fines (typically silt) create pore spaces that facilitate capillarity and freezing point depression. The USACE frost design and classification system is a universal standard for addressing frost heave behavior. Critical conditions for pipeline frost heave distress occur where the pipeline traverses abrupt contrasts in soil conditions and the soils freeze and thaw repeatedly (seasonally).

Additional geotechnical parameters needed to forecast frost heave include permeability, pressure on the freezing front; frost penetration rate and frost heaving rate; longitudinal, bearing and uplift resistance; soil load/deflection and creep characteristics; soil temperature gradient, and climatic data. Many of these parameters can be empirically correlated with the results of geotechnical tests listed above. A probabilistic approach to assigning soil properties may be adopted if sufficient sample data is acquired by the project. When data gaps are identified, they will be filled as necessary. Climatic data will be updated to include most recent data from stations along the route. Limits of applicability of climatic data will be based on geographic similarities along the line.

#### 7.4.3 Analysis

The approach to frost heave analysis was to combine route soils data with climatic data and pipeline thermal predictions and pipe deformation analysis. Thermal conditions of the pipeline and ground were predicted using a coupled hydraulics/geothermal model. This model was comprised of a linear hydraulics model of the pipeline with two-dimensional ‘slices’ of soil defined at intervals along the pipeline. The slices are defined principally by the terrain unit analysis, thus geotechnical information will accompany each slice that allows prediction of frost heave. The hydraulics model predicts temperatures along the pipeline for a given throughput, inlet temperature and pressure, initial soil temperatures, and gas properties. The pressure and temperature of the flowing gas depends upon the heat flux through the pipe wall which, in turn, depends on the pipe interaction with the subsurface thermal state (ground temperatures).

Predictions of the ground temperatures surrounding the pipe were made by the geothermal model. The model considers a two-dimensional ‘slice’ of the pipe surrounded by soil regions and bounded on the surface by location dependent varying climatic functions.

A finite element approach was applied to develop a series of ‘snapshots’ along the pipeline of the changing thermal condition of the subsurface over time, which in turn are used to estimate the heat flux along the alignment to the flowing gas. The result is an estimate of the magnitude and timing

of freezing of initially thawed ground including the geometry of the evolving frost bulb. The same process is used to predict thawing of initially frozen ground.

The pipe/soil thermal regime and geotechnical properties that define the soil's frost susceptibility was then used to predict the amount of heave beneath the pipeline. The frost heave predictions were calibrated against results of previous frost heave laboratory and field testing performed by the research community and special testing completed by industry for other projects.

#### 7.4.4 Segment by Segment Design

Using route geotechnical data in conjunction with the results of the demand and capacity analyses, a segment-by-segment design will be completed to identify the frost heave potential along the alignment. The four possible outcomes from application of the ASAP design flow chart are briefly described below:

- Areas of continuous permafrost, low water table, or where the pipeline operating temperature is greater than 32°F will not be susceptible to frost heave and therefore no rigorous frost heave analysis will be required.
- Areas where the predicted combined pipe stress due to frost heave for the critical span length remain below the allowable combined stress as per ASME B31.8 are classified as having low heave potential and no special mitigative measures will be implemented.
- Areas where the predicted curvature (from digital pigging analysis) due to frost heave for any span length remain below the allowable curvature are classified as being heave susceptible and will require ongoing monitoring. Should the measured curvature reach the intervention curvature limit over time then mitigative measures will be implemented.
- Areas where the predicted curvature (from digital pigging analysis) due to frost heave for any span length exceed the allowable curvature are classified as having high heave potential and mitigative measures will be implemented during design and construction.

#### 7.4.5 Potential Design Mitigative Measures for Frost Heave

For those pipeline route segments where the estimated heave potential may exceed the ability of the pipe to withstand the imposed displacement, a number of mitigative options, or combinations of options, could be employed to reduce the potential for deleterious movement including:

- Reroute within the alignment corridor to a non-frost-susceptible terrain unit, if available;
- Reroute within the alignment corridor to avoid an obvious surficial hazard, such as a pingo or polygonal ground;
- Investigate the subsurface of the suspect terrain segment more closely so as to reduce the conservatism inherent in the station to station approach;
- Change the operating temperature profile of the segment so as to reduce the freeze potential, e.g., by adding heater stations, cycling the temperature, etc.;
- Insulate the pipe ditch to reduce the heat flux through the frost-susceptible soil;

- Increase the pipe wall thickness to increase the resistance of the pipe to ditch displacements, as well as increasing the ability of the pipe to withstand higher displacements;
- Over-excavate the frost-susceptible soil beneath the buried pipeline and replace with non-frost-susceptible soils;
- Increase the burial depth of the pipeline;
- Excavate soils with high uplift resistance above the pipe springline and replace with soils with low uplift resistance;
- Heat trace the soil underneath the pipe to counteract frost penetration;
- Emplace stand-alone heat pipes to freeze the soil quickly, reducing the ability of the frost-susceptible soil to cause large soil volume changes; and
- Combine compatible concepts presented above.

## 8. CONSTRUCTION RELATED ISSUES

### 8.1 CONSTRUCTION SEASONALITY AND ROW MODE

The current ASAP construction plan calls for both summer and winter construction. Winter construction is planned for the first 57 miles of the pipeline (on the Arctic Coastal Plain). The winter construction allows for reduced impact to the ground surface through the use of either ice pad, ice and grade, or frost pack and grade as ROW modes. To the extent practicable, ASAP has planned for permafrost areas to be constructed during the winter to minimize impact to the permafrost through the use of a lower impact ROW mode. Other ROW modes are gravel, gravel and grade, grade, and grade and mats. These other ROW modes are utilized as required based on the local geotechnical conditions, and may be used during winter or summer construction.

### 8.2 GIRTH WELD QUALIFICATION PROCEDURES

To ensure high quality welds, a reasonable amount of flexibility is needed in welding parameters to allow welders the ability to manipulate the process and reduce the likelihood of producing unacceptable weld imperfections. The acceptable ranges of parameter variability that are intended to provide the performance that is similar to the completed qualification test welds will be established.

Weld qualification testing will bound the variability of critical parameters. In particular, heat input is critical because heat input modifies the metallurgical features of the HAZ and weld metal. Weld procedures will be qualified to a full suite of small scale tests and may also include large scale performance testing such as curved wide plates or full-scale tension tests with artificial defects. A test program that confirms the adequacy of the welds to provide resistance to fracture with a weld defect at the extreme of the welding process parameters acceptable during construction will be conducted. The welding procedure will qualify to meet 49 CFR 192.225.

### 8.3 AUTOMATED ULTRASONIC TESTING

Qualification of inspection equipment is critical to the successful implementation of an SBD. Materials qualification for SBD is intimately tied to the establishment of defect acceptance criteria with height and length restrictions. Radiographic testing does not give qualitative information about defect height and is therefore not suitable for an SBD. In order to determine both defect height and length with confidence, automated ultrasonic testing (AUT) will be required. A qualification program will be required to establish not only the detection capability, but also the sizing accuracy of the AUT system to be used during construction. The AUT system will be capable of detecting the critical defect height with high confidence. The sizing error of the system will be established for the range of defect dimensions at the acceptance limit. This error will be subtracted from the critical defect size to establish the acceptance criteria to be used during pipeline welding.

## 8.4 UNEXPECTED SUBSURFACE CONDITIONS

In the event that unexpected subsurface conditions are encountered during construction, the construction and quality inspectors will refer to the Project Field Design Change Manual (FDCM). The FDCM is a yet to be developed manual outlining how certain subsurface conditions are to be mitigated while in the field.

## 9. OPERATIONS AND MAINTENANCE

### 9.1 MONITORING

During design the thaw settlement potential along the alignment will be evaluated using the available route alignment data combined with the line pipe capacities and advanced engineering simulation methodology to explore the potential interaction between the soil subsurface and the pipe during its operational life. To address the differential values along the route, soil displacements and resistance values will be estimated using the landform characteristics along the route derived from the project geo-database. Scrutiny will continue throughout the operational life of the pipeline.

A key consideration in any strain-based pipeline design is the ‘monitor and maintain’ component of the design philosophy. Periodic monitoring of the pipeline will identify locations that are of concern with respect to the pipe structural integrity. The monitoring interval is selected such that there will be enough time to plan and undertake intervention prior to the pipe experiencing a loss of structural integrity.

The best way to monitor curvature along ASAP is through periodic ILI surveys. An ILI geometry survey provides the most practicable and reliable way to accurately characterize the geometry of the entire length of the pipeline. Use of a high resolution inertial navigation system (INS) based geometry tool will result in the highest possible level of survey accuracy.

Several ILI vendors offer high resolution INS tools. The instrumentation on these tools includes a strap down, tri-axial fiber optic gyroscope based Inertial Measurement Unit (IMU), a tri-axial accelerometer, an odometer as well as a multi-arm mechanical caliper. The gyroscopes measure the change in orientation of the pig in terms of the pitch, azimuth, and roll angles; the odometer measures the along-the-pipe distance coordinate tie-points; and the calipers measure pipe ovality or dents and also locate the pipeline girth welds. The gyroscope and odometer data can be numerically differentiated to compute the pipeline curvature (which is proportional to the bending strain) or numerically integrated to estimate the pipe position between coordinate tie-points. Typical accuracies of inertial survey tools are as follows:

- Curvature Detection:  $\pm 0.02\%$  Strain
- Bend Angle Detection:  $\pm 0.1^\circ$
- Dent/Ovality:  $\pm 2.5$  mm
- Weld-to-Weld Distance:  $\pm 12.5$  mm
- Mapping Accuracy 1:2000 (depends on distance between coordinate tie-points)

Since the early 1990’s, the pipeline industry has gained experience with these tools and they have become a key component of pipeline systems which incorporate the ‘monitor and maintain’ component of the SBD philosophy. While the pipeline (X-Y-Z) position mapping is useful for GIS applications and pipeline location, the most important result from an inertial survey of a pipeline for structural integrity assessments is the curvature/bending strain not associated with intentional

bends. The caliper data can also be extremely useful for establishing out-of-roundness and incipient wrinkling deformations of the pipe wall at high curvature/bending strain locations. Note the terms curvature ( $\Psi$ ) and bending strain ( $\epsilon_{bending}$ ) are used somewhat interchangeably herein (since  $\epsilon_{bending} = \Psi D/2$ ).

An important consideration of the ASAP ILI program will be an initial/baseline geometry survey of the pipeline as soon as practicable after construction. This survey will provide a detailed characterization of the as-installed pipeline geometry for comparison with subsequent surveys. Survey-to-survey curvature changes can be used as a basis for estimating the rate of curvature accumulation at any areas of concern. The ASAP curvature monitoring program will establish a curvature limit associated with the governing pipe tension or compression strain limits and an intervention curvature limit will be established as some fraction of the curvature associated with the governing strain limit. The idea is that when high curvature locations are identified, the current curvature and the rate of curvature change can be measured against the intervention curvature limit which will provide a threshold condition at which an intervention can be planned and executed with sufficient time before the curvature reaches that associated with the governing strain limit. This monitoring approach is illustrated conceptually in Figure 18.

For most pipelines, ILI runs are scheduled at relatively wide time intervals. Although design and operational experience will allow evaluation of time-dependent threats and the ability of ILI monitoring to check this threat before it reaches operational limits, the value of direct visual monitoring of the pipeline ROW and ditch position done on a much more frequent basis and its value in finding evolving problems should not be overlooked.

Ground surveillance or aerial reconnaissance procedures should include specific instructions and training to enable operational personnel to correctly identify potential problems associated with pipe movements. Such visual conditions could include:

- Surface expression of ground movements such as tension cracks in the soil, humping of the soil over the ditch, depressions in the pipe ditch
- Interruption or ponding of surface water across or along the alignment
- Localized vegetative changes over the ditch

If the above conditions are found, the operations personnel will note the location, ponding or surface water disturbances will be mitigated, and these locations will have increased scrutiny during future ground surveillance.

## 9.2 POTENTIAL OPERATIONAL MITIGATIVE MEASURES

For those pipeline route segments where the evaluation of ILI or other measurement data shows the effect on the pipe due to frost heave or soil frost heave may exceed the ability of the pipe to withstand the imposed displacement, mitigative options, or combinations of options, could be employed to reduce the criteria exceedance potential during operations. Some of these are seen to be

the same as for design, although the practical ability to employ them during operations may be limited. The options include:

- Insulate the pipe ditch to reduce the heat flux through the frost-susceptible soil;
- Excavate soils with high uplift resistance above the pipe springline and replace with soils with low uplift resistance;
- Elevate the pipeline aboveground placing it in an embankment. Elevating the pipe would reduce or eliminate the heat extracted from the ground;
- Emplace stand-alone thermosyphons to freeze the soil quickly, reducing the ability of the frost-susceptible soil to cause large soil volume changes; and
- Combine compatible concepts presented above.

All areas which have been mitigated during operations will continue to be monitored for any additional issues.

### 9.2.1 Revegetation

Revegetation is the primary method for stabilization of frozen subsurface soils. The *Stabilization and Revegetation Plan* (SRP) has been developed by the Project and the State of Alaska Plant Material Center for ASAP (ASAP-22-PLN-LND-DOC-00001). The SRP has seed mixes and best practices for revegetation and soil stabilization based on the climate zones of the project.

An example of successful revegetation by the Alaska Department of Natural Resources, Division of Agriculture, Plant Material Center at Dalton Highway MP105 is the Kanuti Pit. Photos of the results are shown in Figure 28.

Figure 28. Revegetation of Kanuti Pit, Photo Point 3



6/5/03

9/23/03



8/31/04

8/16/05



8/8/06

8/21/07

### 9.2.2 Temperature Control

Another potential operational philosophy that might be considered is temperature control or temperature cycling of the surrounding soils.

The most common method of temperature control would be the use of thermosyphons if the local climate is conducive to their use. The thermosyphon can mitigate thawing around the pipe and stabilize the thaw settlement by freezing the recently thawed ground.

An example of a thermosyphon installation in a below grade pipeline configuration is shown in Figure 29. Thermosyphons used for an above grade pipeline application is shown in Figure 30.

**Figure 29. TAPS Buried Segment with Thermosyphons**



Figure 30. TAPS Aboveground Pipeline with Thermosyphons



### 9.2.3 Line Leveling

Line-leveling is one possible form of intervention/mitigation that can be employed should the measured curvature approach or exceed the curvature limits established for the project. This would entail excavating the line in areas experiencing frost heave and re-leveling the line to reduce the curvature. The line-leveling can be by excavating and exposing the settling segment, and raising the pipe by:

- Lifting the pipe with cranes
- Lifting the pipe with pipe layers
- Jacking the pipe up with airbags

New backfill material is placed under the raised pipe then the pipe is lowered onto the new bedding material and the trench backfilled.

## 10. CONCLUSION

The design approach to time dependent route geohazards as explained in this report is summarized in Figure 3, which shows the flow of the various steps needed to define and begin the assembly of the components of the project approach in preliminary design; finalize the assembly and verification and apply the approach to the alignment in final design; and continue route monitoring and potential mitigation throughout operations. In the current FEL phase of the project, the design approach is being developed and scoped for initiation during the next phase.

AGDC is committed to the complete development and verification of the design approach for application throughout the design life. As the development progresses, AGDC will continue to enhance the ongoing verification and application studies throughout this process to ensure the safety and integrity of the pipeline.

## 11. REFERENCES

- Andersland, Orland B. and Branko Ladanyi. 2004. *Frozen Ground*. 2<sup>nd</sup> Edition. Published in cooperation with ASCE Press. John Wiley & Sons, Inc. Table 2-7.
- ASCE. 1984. "Guidelines for the Seismic Design of Oil and Gas Pipeline Systems." Committee on Gas and Liquid Fuel Lifelines.
- Bureau of Land Management (BLM). 2002. *Final Environmental Impact Statement Renewal of the Grant for the Trans-Alaska Pipeline System Right-of-Way*. Environmental Impact Statement, Department of the Interior, Bureau of Land Management.
- COLTKBR. 2003. "Conceptual Geotechnical/Geothermal Design Basis." Rev. B. [http://www.ngps.nt.ca/Upload/Proponent/Imperial%20Oil%20Resources%20Ventures%20Limited/050922\\_IORVL\\_to\\_JRP\\_R2\\_Q39-45-geo.pdf](http://www.ngps.nt.ca/Upload/Proponent/Imperial%20Oil%20Resources%20Ventures%20Limited/050922_IORVL_to_JRP_R2_Q39-45-geo.pdf)
- COLTKBR. 2007. "Frost Heave Structural Analysis of the Ochre River HDD Crossing." Rev. 1. <https://www.neb-one.gc.ca/ll-eng/livelink.exe?func=ll&objId=477649&objAction=browse>
- United States Army Corps of Engineers, Cold Regions Research & Engineering Lab, <http://www.erd.usace.army.mil/Media/FactSheets/FactSheetArticleView/tabid/9254/Article/476647/permafrost-experiment-station.aspx>
- United States Army Corps of Engineers, Cold Regions Research and Engineering Laboratory, "Review of Thermosyphon Applications", ERDC/CRREL TR-14-1, February 2014
- Hart, J.D., G. Antaki, et.al. 2001. "Guidelines for the Design of Buried Steel Pipe." Published by the ASCE American Lifelines Alliance. [www.americanlifelinesalliance.org](http://www.americanlifelinesalliance.org).
- Hart, J.D., G.H. Powell, and N. Zulfiqar. 1996. "A Material Model for Pipeline Steels." ASME Offshore Mechanics and Offshore Engineering International Pipeline Conference. Calgary, Alberta, Canada.
- Honegger, D.G., and D. J. Nyman. 2004. "Guidelines for the Seismic Design and Assessment of Natural Gas and Liquid Hydrocarbon Pipelines." Pipeline Research Council International, Inc. Catalog No. L51927.
- Honegger, D.G. "Guidelines for Constructing Natural Gas and Liquid Hydrocarbon Pipelines Through Areas Prone to Landslide and Subsidence Hazards", Prepared by C-Core, D.G. Honegger Consulting and SSD, Inc. for PRCI, January 2009.
- Hwang, C.T., 1976. "Predictions and observations on the behaviour of a warm gas pipeline on permafrost". *Can. Geotech. J.*, vol. 13, pp. 452-480.

- Konrad, J.M. and N.R. Morgenstern. 1981. "The Segregation Potential of a Freezing Soil", Canadian Geotechnical Journal, 18: 482-491.
- Linell, K. A., 1973. "Long-term Effects of Vegetative Cover on Permafrost Stability in an Area of Discontinuous Permafrost", Second International Conference on Permafrost, pp. 688 to 693.
- Matrix, 2013. "Surface energy balance models and climate change considerations for geothermal simulations: Alaska Stand-Alone Pipeline Project". Technical Memorandum. Matrix Solutions Inc. Calgary, Alberta. November 1, 2013.
- Matrix, 2015, "Long-Term Thaw Depth Modeling of Surface Disturbance at the Fairbanks Surface Disturbance Test Site". Report, Matrix Solutions Inc., Calgary, Alberta. January 2015.
- Matrix, 2016, "Pipeline Thaw Depth and Thaw Settlement Predictions, Alaska Stand-Alone Pipeline". Report, Matrix Solutions Inc., Calgary, Alberta. January 2016.
- Mroz, Z. 1967. "On the Description of Anisotropic Work Hardening." Journal of Mechanics, Physics and Solids, 15, 163-175.
- Nakai, T., Kim, Y., Busey, R. C., Suzuki, R., Nagai, S., Kobayashi, H., Park, H., Sugiura, K., Ito, A., 2013. "Characteristics of evapotranspiration from a permafrost black spruce forest in interior Alaska", Polar Science 7, no. 2, pp. 136--148.
- Popov, E.P. 1976. "Mechanics of Materials." 2nd Edition. Prentice Hall.
- SSD, Inc., "PIPLIN: Stress and Deformation Analysis of Pipelines", Version 4.58, User Reference and Theoretical Manual, Reno, Nevada, February 2011.
- State of Alaska Department of Natural Resources, Division of Agriculture, Plant Materials Center "Rehabilitation of the Kanuti Pit Materials Site 65-9-031-2 Located at Milepost 105 of the Dalton Highway" March 6, 2008.
- State of Alaska Department of Natural Resources, Division of Agriculture, Plant Materials Center "Stabilization and Revegetation Plan, June 22, 2016

## APPENDIX A: STRUCTURAL MECHANICS OF BURIED PIPELINES

Although some sections of the ASAP are aboveground, notably at waterway and fault crossings, ASAP is primarily a buried pipeline. Buried pipelines are essentially “restrained,” that is, displacement of the pipe is restricted by the soil around it.

Engineering calculations typically address the pipe in a bi-axial stress state called plane stress. The active stresses considered in pipe engineering calculations are shown in Figure B. 1 – a hoop stress and strain which act around the circumference of the pipe, and a longitudinal stress and strain which are directed along the long axis of the pipe. In general, there is a third stress, a shear stress, which could be acting on the edges of the above unit section, but this is not normally significant and usually neglected in engineering calculations of transmission pipelines. Pipelines with diameter to wall thickness ratios ( $D/t$ ) greater than 20, typical of transmission pipelines, are considered “thin-walled” as the distribution of normal stress perpendicular to the surface is essentially uniform throughout the wall thickness.

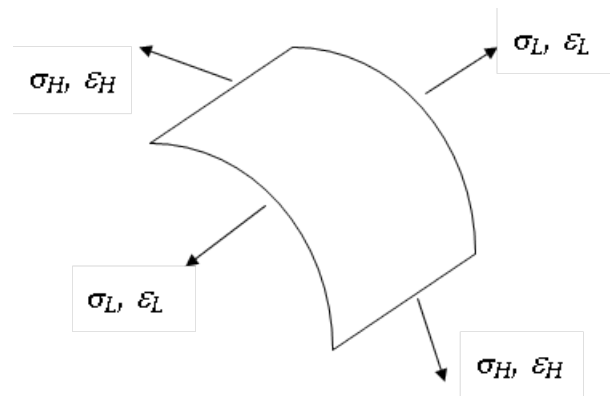

**Figure B. 1** Pipe Stresses and Strains

The relation between stress ( $\sigma$ ) and strain ( $\varepsilon$ ) for pipeline steel when loaded in one direction (i.e., a uniaxial stress-strain curve) can be generally represented as shown in Figure B.2. Below the proportional limit, the stress is linearly related to the strain, a relation called Hooke’s law, given by:

$$\sigma = E\varepsilon \quad \text{Equation B.1}$$

with the constant “ $E$ ” known as the Young’s modulus. The yield point for pipeline engineering is defined by testing requirements to be the point at which the specified minimum yield strength (SMYS) of the pipe is recorded – 0.5% strain. Note that this definition of the “yield” does not concisely fit classical “textbook” definitions of yield, which is often defined as the point at which non-recoverable, i.e. “plastic” deformations, initiate. For example, if the pipe material was considered to be governed by Hooke’s law to SMYS of 70 ksi, the associated strain would be only:

$$\varepsilon = 70\text{ksi} / 29,500\text{ksi} / \text{in} / \text{in} = 0.00237\text{in} / \text{in} = 0.237\%$$

Thus, to reach the strain associated with SMYS an additional 0.263% strain occurs, which cannot be accounted for by an elastic relationship. Note that alternative yield point definitions are defined using an “offset” method where a line with the elastic slope is drawn from a specified strain offset point – again confirming the necessary incorporation of non-recoverable (plastic) deformation just to reach SMYS.

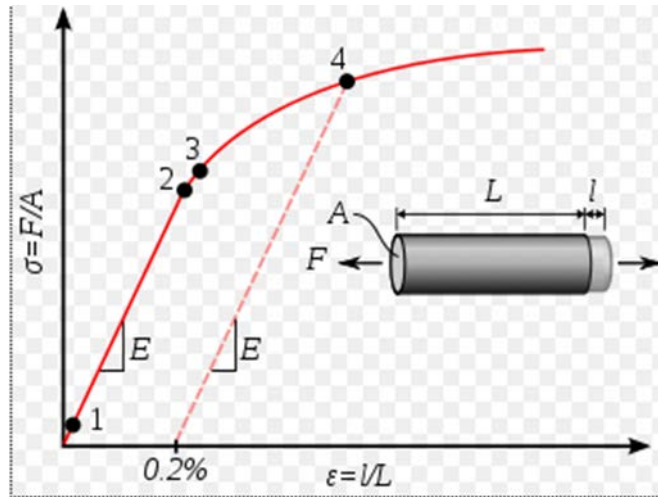

**Figure B.2 Typical Pipe Stress-Strain Uniaxial Curve**

where:

1. True Elastic limit (first dislocation)
2. Proportionality Limit
3. Elastic Limit
4. Yield point

Below the proportional limit of the pipe stress-strain curve, where the stresses and strains are linearly related the relationship between stress and strain under plane stress conditions can be expressed as:

$$\begin{pmatrix} \epsilon_H \\ \epsilon_L \end{pmatrix} = \frac{1}{E} \begin{bmatrix} 1 & -\nu \\ -\nu & 1 \end{bmatrix} \begin{pmatrix} \sigma_H \\ \sigma_L \end{pmatrix} \tag{Equation B.2}$$

where:

- $E$  is the Modulus of Elasticity, sometimes called Young’s modulus. For steel in the temperature range of operations, the value is approximately 29,500 ksi/in/in;
- $\epsilon_H$  is the strain in the hoop direction;
- $\epsilon_L$  is the strain in the longitudinal direction;

$\sigma_H$  is the stress in the hoop direction;

$\sigma_L$  is the stress in the longitudinal direction; and

$\nu$  is Poisson's ratio which is defined as the negative of the ratio of strain perpendicular to the load to the strain parallel to the load, and is a constant for stresses below the proportional limit. The value of Poisson's ratio for steel is 0.3.

## B.1. HOOP STRESS

Hoop stress ( $\sigma_H$ ), also known as "circumferential stress" is the normal stress on a longitudinal plane through the pipe centerline (see Figure B.3) resulting from internal forces ( $Q$ ) resisting the fluid pressure force ( $P$ ).

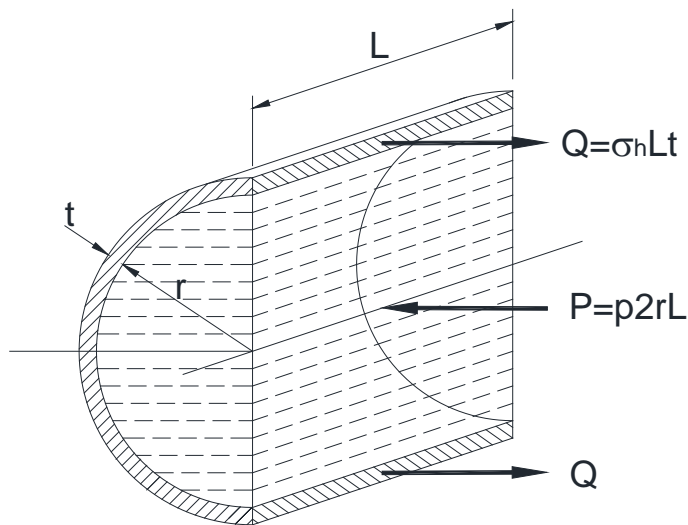

Figure B.3 Hoop Stress Free Body Diagram

To satisfy the equilibrium equation:

$$\sum F_y = 0 = P - 2Q$$

With  $P = p2rL$  and  $Q = \sigma_H Lt$ ; then

$$p2rL - 2\sigma_H Lt ; \text{ or}$$

$$p2rL = 2\sigma_H Lt ; \text{ or}$$

$$\frac{p2r}{2t} = \sigma_H ; \text{ setting } 2r \text{ to } d \text{ gives:}$$

$$\sigma_H = \frac{pd}{2t}$$

Equation B.3

This formula is commonly known as **Barlow's Formula** and is the base equation used in 49 CFR 192 to determine the design pressure for steel pipe after applying a design factor, a longitudinal joint factor, and a temperature derating factor.

## B.2. LONGITUDINAL STRESS

The typical causes of longitudinal stress in buried pipelines are:

- Changes in steel temperature that, under unrestrained conditions, would cause lengthening or shortening of the pipe;
- Changes in internal pressure that, under unrestrained conditions, would cause lengthening or shortening of the pipe; and
- Transverse bending (flexure) of the pipe as it conforms to outside forces/displacements, such as frost heave or thaw settlement.

In straight pipe, the longitudinal strains due to internal pressure and temperature differential act uniformly across the section of the pipe. Transverse bending causes a linear variation in longitudinal strain across the section of the pipe. These relationships are illustrated in Figure B.4.

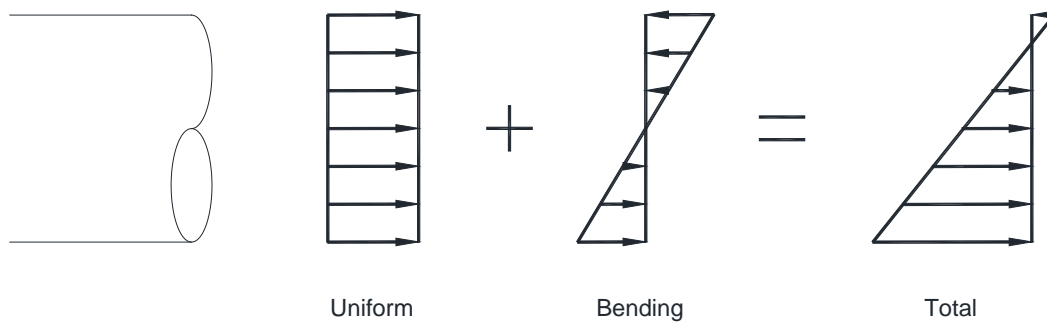

**Figure B.4 Uniform, Bending and Total Longitudinal Pipe Strains**

### PRESSURE EFFECT ON LONGITUDINAL STRESS/STRAIN

As noted in Equation B.2, there is a relation between stress and strain for the two stress components of interest, and this relation can be used to derive additional information about the stress state. For example, although the hoop stress is directly related to the containment pressure, there is also an effect of the containment pressure on the longitudinal stress components.

In the elastic range, the associated longitudinal stress due to the pressure effect in the buried line can be found by substituting the known hoop stress for the pressure containment and noting that the longitudinal strain for a fully restrained pipe is zero, and then using this information in Equation B.2:

$$\begin{pmatrix} \varepsilon_{H-pressure} \\ 0 \end{pmatrix} = \frac{1}{E} \begin{bmatrix} 1 & -\nu \\ -\nu & 1 \end{bmatrix} \begin{pmatrix} pd/2t \\ \sigma_{L-pressure} \end{pmatrix}$$

By the second equation:

$$0 = \frac{-\nu pd}{E2t} + \frac{\sigma_{L-pressure}}{E}; \quad \text{or:}$$

$$\sigma_{L-pressure} = \frac{\nu pd}{2t} = 0.3\sigma_H \quad \text{Equation B.4}$$

For aboveground, i.e., unrestrained sections of the pipe, the longitudinal strain is not zero

---

### TEMPERATURE

For a pipeline that is free to expand, the strain caused as a result of temperature differential (change in temperature of the pipe steel from its installation temperature) is defined by:

$$\varepsilon_{L-temp} = \alpha(T - T_i)$$

where:

$\varepsilon_{L-temp}$  is the longitudinal strain due to temperature (in/in) in an unrestrained pipeline;

$\alpha$  is the coefficient of thermal expansion (in/in/°F);

$T$  is the temperature for the state of interest (°F); and

$T_i$  is the installation temperature (°F)

In aboveground segments of the pipeline, the thermal expansion and contraction is partially restrained and so produces longitudinal force and induces secondary longitudinal bending stress especially where the pipe configuration affords this partial restraint to thermal movement, such as near supports and at and near bends, and offsets. The design temperature differential is typically input into a pipe/structural analysis program in combination with other applicable loads to find the effects of these load components on aboveground segments.

A fully restrained pipeline has a net longitudinal strain of zero – i.e., it resists that tendency to expand with an equal and opposite mechanical strain of:  $\varepsilon_{L-temp} = -\alpha(T - T_i)$ , thus producing a total net strain of zero.

In the elastic range, the associated stress due to thermal restraint in the buried line can be found by noting that the associated hoop stress for this load is zero, and then using this information in Equation B.2:

$$\begin{pmatrix} \varepsilon_{H-temp} \\ \varepsilon_{L-temp} \end{pmatrix} = \frac{1}{E} \begin{bmatrix} 1 & -\nu \\ -\nu & 1 \end{bmatrix} \begin{pmatrix} 0 \\ \sigma_{L-temp} \end{pmatrix}$$

By the second equation:

$$\varepsilon_{L-temp} = \frac{\sigma_{L-temp}}{E}; \quad \text{or:}$$

$$\sigma_{L-temp} = E\varepsilon_{L-temp} = -E\alpha(T - T_i) = E\alpha(T_i - T) \quad \text{Equation B.5}$$

As can be seen from the equation, operating temperatures that are less than the installation temperature would cause a longitudinal tensile component (stress component is positive), while operating temperatures that are greater than the installation temperature would cause a longitudinal compressive component (stress component is negative).

## BENDING

When an initially straight pipe is bent into a circular arc, longitudinal strains, and stresses, develop through the pipe cross-section in the plane of the bend. Below the proportional limit the longitudinal strain and stress in the extreme fibers of the pipe cross section are defined by:

$$\varepsilon_{L-bending} = \pm r/R \quad \text{and} \quad \sigma_{L-bending} = \pm Er/R$$

where:

$\varepsilon_{L-bending}$  is maximum longitudinal strain due to bending (in/in);

$\sigma_{L-bending}$  is maximum longitudinal stress due to bending (psi);

$r$  is the outside radius of the pipe section (in); and

$R$  is the longitudinal radius of the arc of bend of the pipe centerline (in).

When subjected to external forces/displacements a pipe resist via beam action. This beam action induces bending moments within the pipe section, which can be converted to stress by:

$$\sigma_{L-bending} = \pm Mr/I$$

where:

$I$  is moment of inertia of the pipe (in<sup>4</sup>); and

$M$  is bending moment (in-lbf)

### B.3. COMBINED STRESS

The general state of stress in a buried pipeline under a combination of loads can be determined by considering the principal stresses within the pipe. For biaxial stress conditions that exist in pipelines, the principal stresses are the hoop stress ( $\sigma_H$ ) and the longitudinal stress ( $\sigma_L$ ). The longitudinal stress is the summation of longitudinal stresses from temperature, pressure, and bending ( $\sigma_{L-temp} + \sigma_{L-pressure} + \sigma_{L-bending}$ ). Longitudinal stresses from other axial forces, if present, are also included.

#### YIELD CRITERION

The two most commonly used yield criteria for determining effective stresses in pipelines are the maximum shear stress theory, commonly referred to as the Tresca theory, and the maximum distortion energy theory, commonly referred to as the von Mises' theory.

##### (1) MAXIMUM SHEARING STRESS THEORY

As discussed in "Mechanics of Materials" by Popov [Popov 1976], the maximum shearing stress theory is based on the observation that in a ductile material, slipping occurs during yielding along critically oriented planes. This suggests that the maximum shearing stress plays a key role in the yielding behavior. It is assumed that the material yielding depends on the maximum shearing stress so that whenever a critical value  $\tau_{critical}$  is reached, yielding commences. The value of  $\tau_{critical}$  is set equal to the shearing stress at yielding under uniaxial tension ( $+\sigma_y$ ) or compression ( $-\sigma_y$ ) loading:

$$\tau_{max} \equiv \tau_{critical} = \left| \frac{\pm \sigma_y}{2} \right|$$

Hence, the maximum shearing stress is equal to  $\frac{1}{2}$  of the uniaxial yield stress. For biaxial stress conditions that exist in pipelines the corresponding yielding criterion is expressed as follows:

$$|\sigma_H| \leq \sigma_y \quad \text{and} \quad |\sigma_L| \leq \sigma_y \quad \text{and} \quad |\sigma_H - \sigma_L| \leq \sigma_y$$

This is referred to as the Tresca yield criterion. The hexagonal Tresca yield function is illustrated in longitudinal stress vs. hoop stress space in Figure B.5 for an elastic-plastic material with a yield strength of 70 ksi. Any stress falling within the hexagon indicates that the material behaves elastically while points on the hexagon indicate that the material is yielding. This criterion is implemented under B31.8 Section 833.4 to limited combined stress for restrained pipe as:

$$|\sigma_H - \sigma_L| \leq k \cdot S \cdot T$$

where:

$k$  is an allowable stress multiplier (for loads of long duration,  $k$  is 0.90, and for occasional non-periodic loads of short duration it is 1.0);

$S$  is the pipe SMYS; and

$T$  is the temperature derating factor ( $T=1.0$  for temperatures  $\leq 250^\circ\text{F}$ , per B31.8 Section 841.116).

## (2) MAXIMUM DISTORTION ENERGY THEORY

As discussed by Popov [Popov 1976], a widely accepted criterion for yielding of ductile materials is based on energy concepts wherein the total elastic energy of the material is divided into two parts: one associated with volumetric changes of the material, and the other causing shearing distortions. By equating the shearing distortion energy at yield under uniaxial tension to that under combined stress, the yield criterion for combined stress is established. For plane stress conditions, with principal stresses  $\sigma_1$  and  $\sigma_2$ , the yield condition for an ideal plastic material becomes:

$$\left(\frac{\sigma_1}{\sigma_y}\right)^2 - \left(\frac{\sigma_1 \cdot \sigma_1}{\sigma_y \cdot \sigma_y}\right) + \left(\frac{\sigma_2}{\sigma_y}\right)^2 = 1 \quad \text{or} \quad \sqrt{\sigma_1^2 - \sigma_1 \cdot \sigma_2 + \sigma_2^2} = \sigma_y$$

This is the equation of an ellipse as shown in Figure B.5 for an elastic-plastic material with a yield strength of 70 ksi. Any stress falling within the ellipse indicates that the material behaves elastically while points on the ellipse indicate that the material is yielding. This is referred to as the von Mises yield criterion. This criterion is implemented under B31.8 Section 833.4 to limited combined stress for restrained pipe as:

$$[\sigma_L^2 - \sigma_L \cdot \sigma_H + \sigma_H^2] \leq k \cdot S \cdot T$$

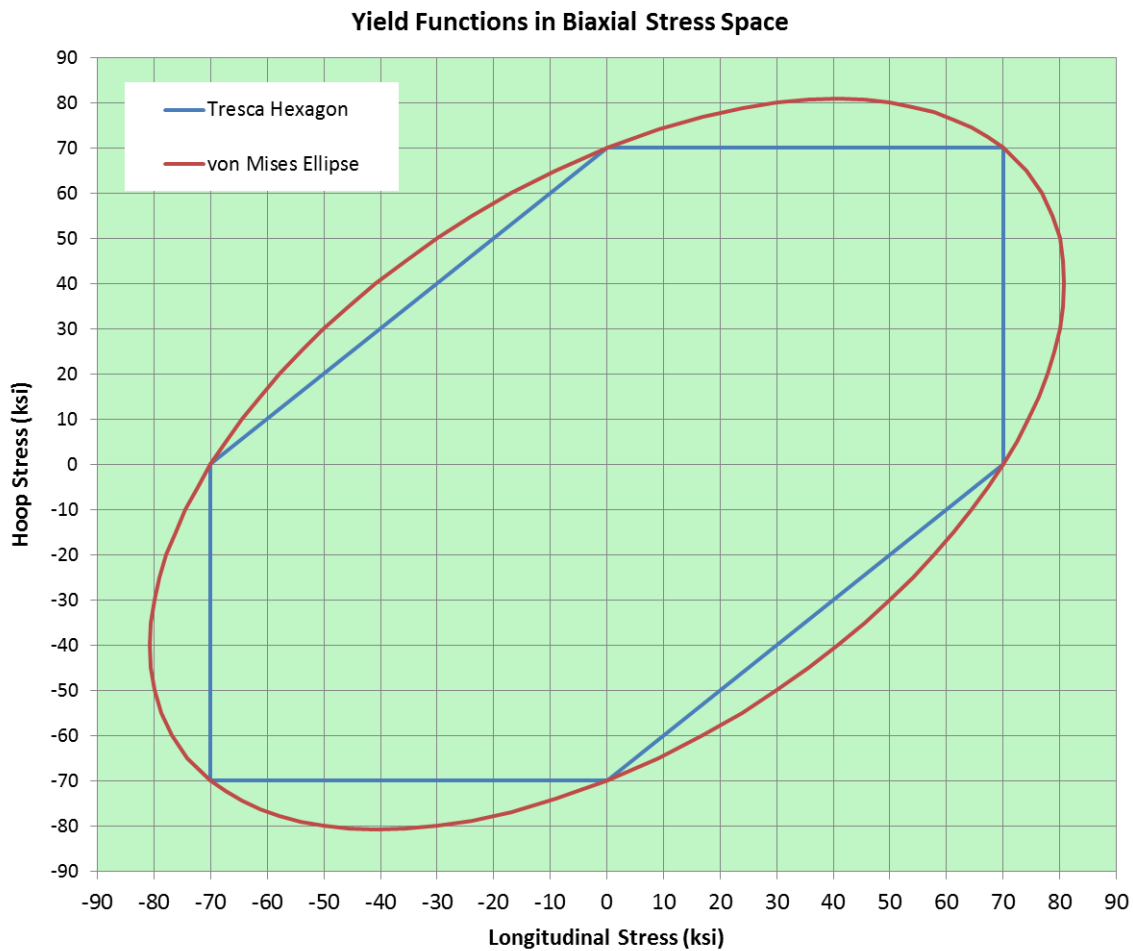

Figure B.5 Illustration of Tresca and von Mises Yield Functions

## APPENDIX B: EXPECTED LONG-TERM THAW DEPTHS IN WARM PERMAFROST ON THE ASAP ROW TECHNICAL MEMORANDUM



# ALASKA STAND ALONE PIPELINE/*ASAP* PROJECT

Technical Memo:  
Expected Long-Term Thaw Depths in Warm  
Permafrost on the ASAP Right-of-Way

ASAP-27-TMM-YYY-REC-00001  
July 8, 2016

## TECHNICAL MEMORANDUM

**TO:** Keith Meyer, Pipeline Engineering Manager, Alaska Gas Development Corp.  
Scott Lust, Pipeline Engineer, Alaska Gas Development Corp.

**FROM:** Ron Coutts, Senior Geological Engineer, Matrix Solutions Inc.

**RE:** **Expected Long-Term Thaw Depths in Warm Permafrost on the ASAP Right-of-Way,  
Alaska Stand-Alone Pipeline Project**

**DATE:** July 12, 2016

### 1 INTRODUCTION

Thermal modeling was undertaken to determine the expected 30-year thaw depths across the ASAP pipeline right-of-way (ROW). In addition it was also necessary to assess thaw beyond the edge of the ROW in adjacent undisturbed terrain.

It is understood that information presented in this report will be passed along for review by the U.S. Army Corps of Engineers.

### 2 TECHNICAL OVERVIEW

Long-term ground temperatures, as characterized by mean annual ground temperature (MAGT), are a result of heat energy exchange between the ground and the above ground environment at the ground surface. The significant energy exchange components at the ground surface are solar radiation, longwave radiation emitted from the ground and snow surface, convective heat transfer with atmospheric air, and evapotranspiration from surface water evaporation and plant transpiration.

Ground surface properties such as summer and winter albedo (surface reflectivity) and evapotranspiration factor affect the net energy flux at the ground surface. For example, summer and winter albedo values, which each range from 0 to 1, affect the amount of solar radiation that is absorbed at the ground and snow surfaces respectively. An albedo value of 0.85 for snow represents 85% reflectance of solar radiation, and correspondingly, 15% absorption of solar radiation at the snow surface. Evapotranspiration factor, which also ranges from 0 to 1, quantifies the degree to which latent heat energy at the ground surface is intercepted to vaporize water by evaporation or by plant transpiration.

A surface energy balance (SEB) model for heat energy exchange at the ground surface developed by Hwang, 1976, was used to determine the net heat energy flux at ground surface nodes in a geothermal

modeling finite element analysis (FEA) of heat transfer in the soil. The FEA tool used was TEMP/W (Geo-Slope 2016).

Ground surface properties of summer albedo and evapotranspiration factor were varied in the SEB model to simulate ground surface disturbances such as tree clearing, the gravel pad surface on the pipeline right-of-way (ROW), and revegetation of ground surfaces disturbed during construction and which are beyond the permanent ROW width.

This technical memo summarizes the geothermal model setup and long-term (30-year) thaw depth results calculated from geothermal modeling. The model conditions are representative of a warm permafrost area near Fairbanks with a mean annual ground temperature of 31.1°F and with ground surface disturbances on the ROW from tree clearing and gravel pad placement.

### **3 GEOTHERMAL MODEL SETUP**

#### **3.1 Domain Geometry**

As shown in Figure 1, the typical pipeline ROW configuration in discontinuous permafrost is planned to be 120ft wide. This includes an 18in thick, 70ft wide gravel pad on one side of the pipe centerline, and a 30ft wide cleared area for trench spoil, each setback 10ft from the pipe centerline. After one construction season, the permanent ROW is planned to be 53ft wide and centered over the pipe. With time, grasses and shrubs and eventually trees (in originally treed areas along the route) will revegetate the ROW. Young trees growing on the permanent 53ft ROW will be cleared while those beyond the 53ft ROW to the edge of the 120ft temporary construction ROW will grow unhindered.

Figure 2 shows the entire geothermal modeling domain representing the typical ROW cross-section described above. Figure 3 shows a closer view of the soil types and boundary conditions over the 120ft wide construction ROW. Note that the length units in these figures are in meters, not feet, as it was necessary to perform the modeling in metric units due to current limitations in the TEMP/W add-in module that computes the surface energy balance flux boundary conditions at the ground surface.

Undisturbed terrain was modeled using an 8in thick organic peat layer overlaying a fine-grained and ice-rich mineral soil. Cleared terrain occurs on the ROW where trees were cleared and the organics layer is preserved. Equipment operating on the spoil side of the ROW during construction will compress the organic layer somewhat. To simulate this disturbance, the organic soil properties were modified to represent compressed organic peat. The 18in thick gravel pad was modeled as either being placed directly on top of the organic layer (having ‘buried’ organic soil properties), or, as a bounding case, with no organic layer below the gravel pad. The 36in pipe was buried with 3 feet of cover depth above the pipe.

The finite element mesh over the entire domain geometry is shown in Figure 4 and included 4721 nodes and 4621 elements. The highest temperature gradients within the modeling domain are near the pipe and downward from the ground surface. In these areas a higher node/element mesh density was used as shown in Figure 5.

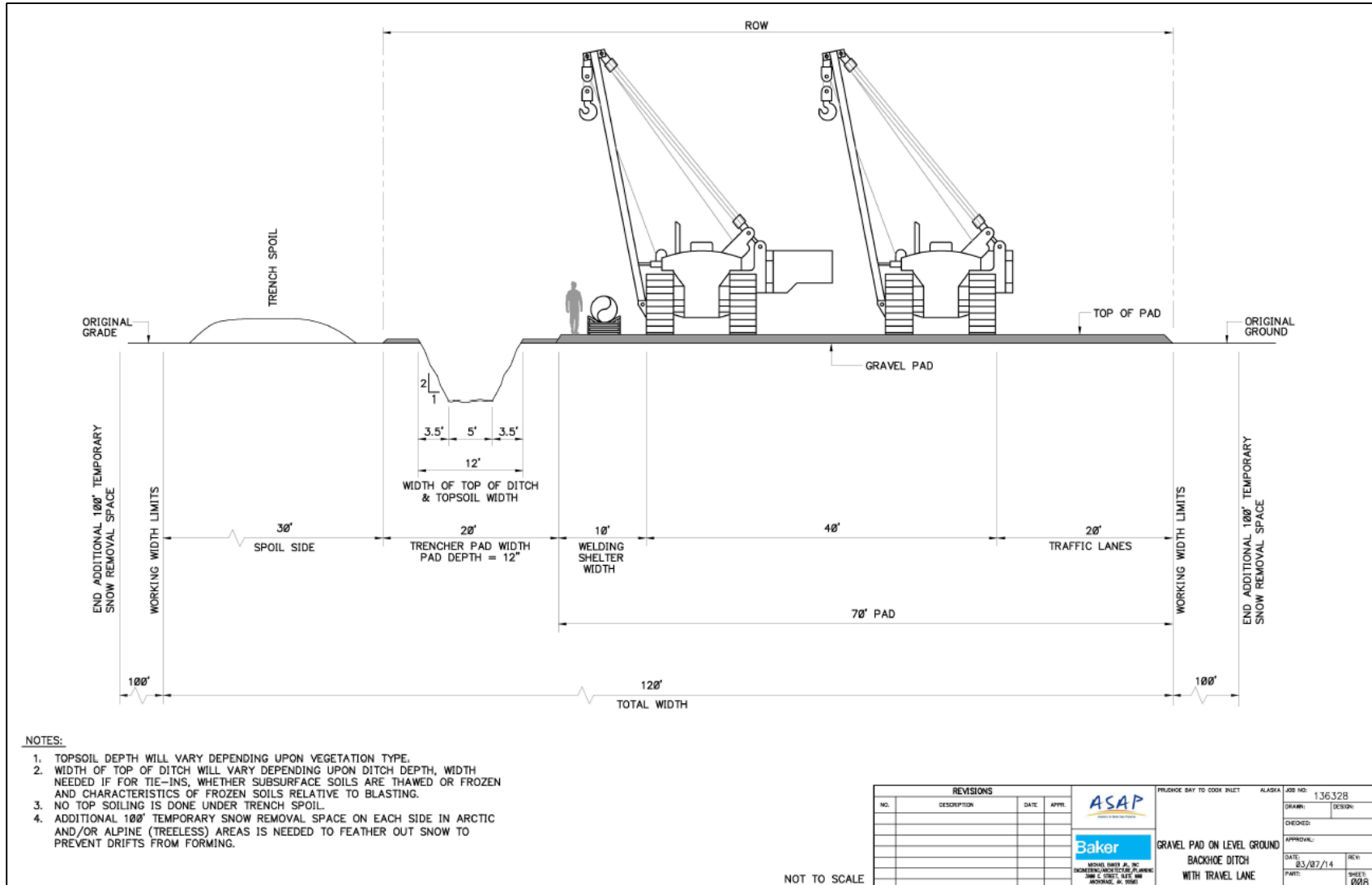

**Figure 1 Typical ROW in Discontinuous Permafrost**

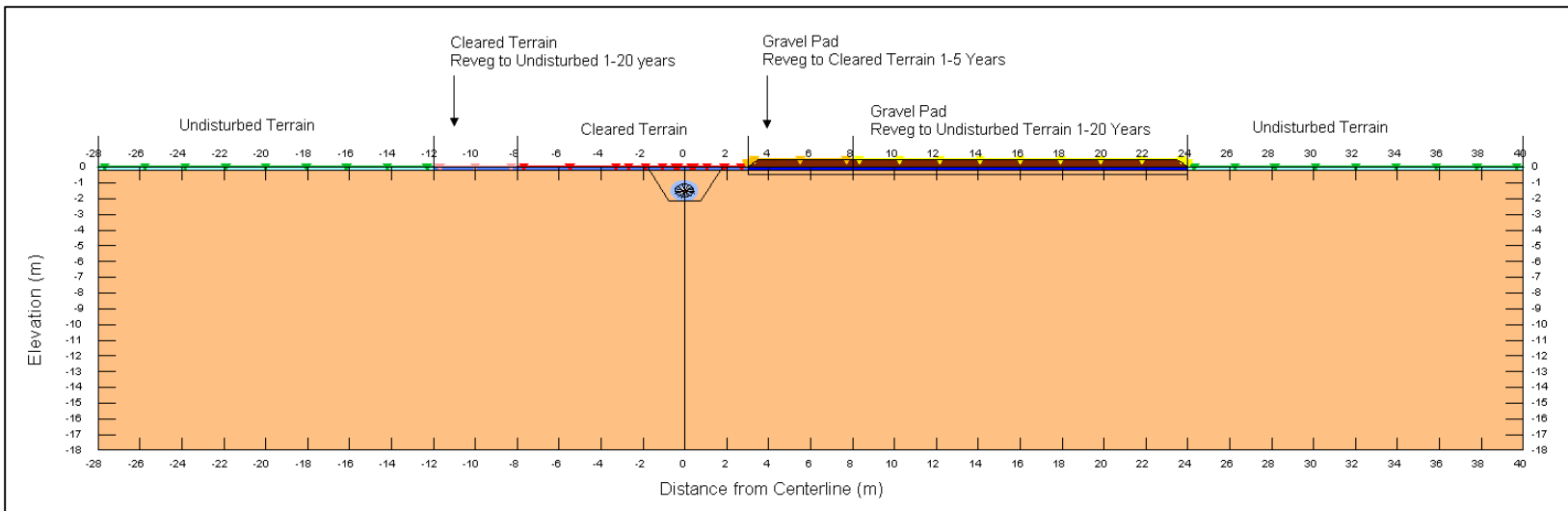

**Figure 2 Geothermal Modeling Domain**

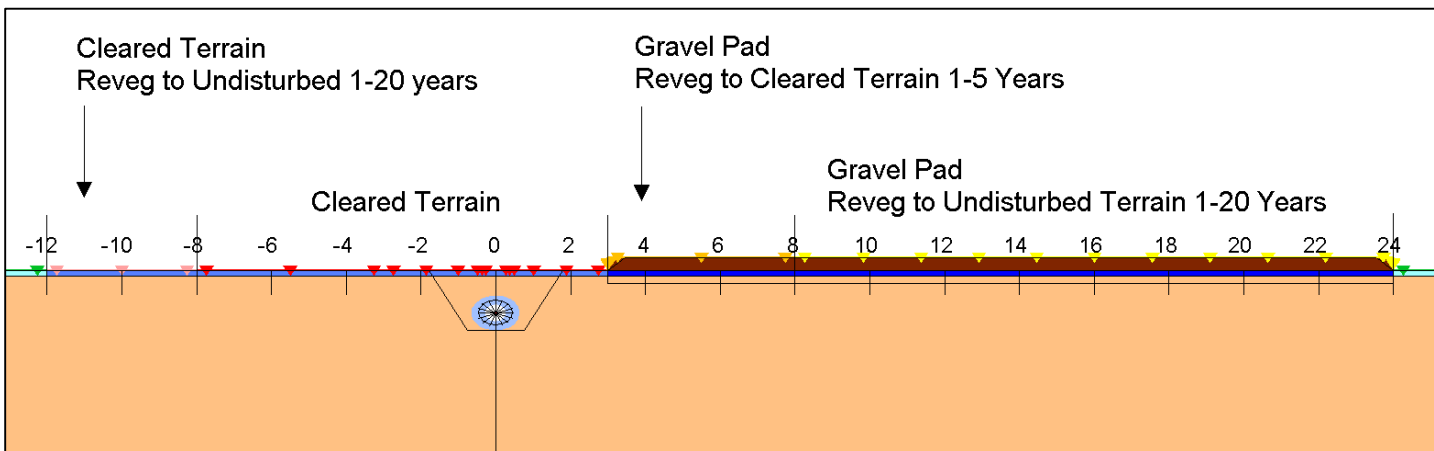

**Figure 3 Soil Types and Boundary Conditions**

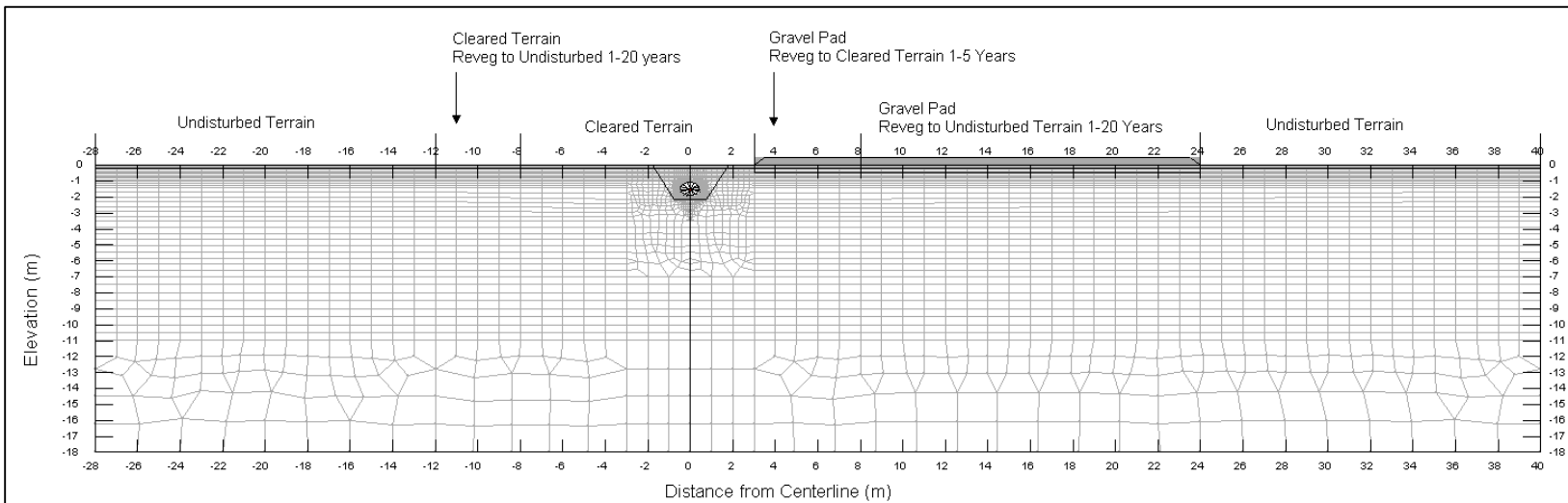

**Figure 4 Finite Element Mesh**

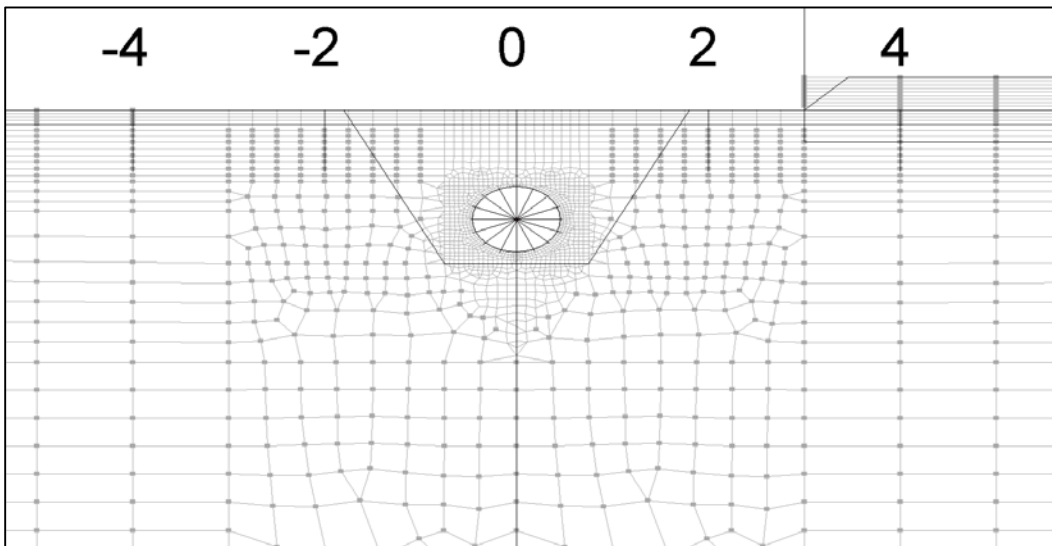

**Figure 5 Finite Element Mesh near Pipe**

### 3.2 Material Properties

Table 1 shows soil property parameters for water saturated fine-grained mineral soil at two moisture contents, for organic soils which are undisturbed, compressed and buried, and for the gravel pad material. For the modeling reported herein, 35% moisture content was used for the fine-grained mineral soil which is representative of ice-rich permafrost.

A constant snow thermal conductivity of 0.29 W/m-°C was used for all analyses and was determined by model calibration as discussed later.

**Table 1 Soil Properties**

Parameter	Sat. Silt & Clay Soil w=35%	Sat. Silt & Clay Soil w=25%	Organic Soil w=200%	Compressed Organic Soil w=150%	Gravel Pad w=10%	Buried Organic Soil w=140%	Unit	Description
Gs	2.67	2.67	1.4	1.4	2.67	1.4	--	specific gravity of solids
n	0.48	0.40	0.76	0.70	0.25	0.66	m3/m3	porosity
S	1.00	1.00	0.90	0.90	0.80	1.00	m3/m3	saturation
w	0.35	0.25	2.04	1.50	0.10	1.40	g/g	gravimetric water content
A	0.100	0.100	0.050	0.050	0.030	0.050	--	unfrozen water content at -1 C
B	-0.300	-0.300	-0.700	-0.700	-0.700	-0.700	--	unfrozen water content function exponent
Ku	1.20	1.40	0.40	0.43	2.70	0.60	J/(s*m°C)	unfrozen thermal conductivity of soil
Kf	2.00	2.00	0.90	0.87	3.20	2.90	J/(s*m°C)	frozen thermal conductivity of soil
L	3.34E+08	3.34E+08	3.34E+08	3.34E+08	3.34E+08	3.34E+08	J/m3	latent heat of water
Cw	4.187E+06	4.187E+06	4.19E+06	4.187E+06	4.187E+06	4.187E+06	J/(m3°C)	heat capacity of water
Ss	0.17	0.17	0.4	0.4	0.17	0.4	--	specific heat capacity of solids
Cu/Cw	0.696	0.651	0.828	0.741	0.540	0.810	--	unfrozen heat capacity of soil relative to water
Cf/Cw	0.463	0.457	0.482	0.449	0.440	0.495	--	frozen heat capacity of soil relative to water
pdry	1350	1550	340	390	2000	450	kg/m3	dry density of soil
pwat	1000	1000	1000	1000	1000	1000	kg/m3	density of water
theta	0.48	0.40	0.68	0.63	0.20	0.66	--	volumetric water content of soil
Ku	103.7	121.0	34.6	37.2	233.3	51.8	kJ/(d*m°C)	unfrozen thermal conductivity
Kf	172.8	172.8	77.8	75.2	276.5	250.6	kJ/(d*m°C)	frozen thermal conductivity
Cu	2915	2724	3467	3103	2260	3390	kJ/(m3°C)	unfrozen heat capacity
Cf	1938	1913	2018	1878	1842	2072	kJ/(m3°C)	frozen heat capacity
L	3.34E+05	3.34E+05	3.34E+05	3.34E+05	3.34E+05	3.34E+05	kJ/m3	latent heat of water

### 3.3 Climate Data

Table 2 provides mean monthly climate normals for Fairbanks. These data were used in the surface energy balance model to determine the net heat energy flux into or out of the ground surface at each node in the thermal model at each time step.

**Table 2 Fairbanks Climate Data**

Month	Air Temp (°C)	Air Temp (°F)	Wind Speed (km/h)	Wind Speed (mph)	Solar Radiation (W/m <sup>2</sup> )	Solar Radiation (BTU/hr/ft <sup>2</sup> )	Snow Depth (cm)	Snow Depth (ft)
January	-23.9	-11.0	4.7	2.9	7.7	2.4	46.2	1.52
February	-19.4	-2.9	6.1	3.8	34.4	10.9	58.0	1.90
March	-12.8	9.0	7.9	4.9	103.6	32.8	50.8	1.67
April	-1.4	29.5	10.4	6.5	182.6	57.9	25.7	0.84
May	8.4	47.1	12.2	7.6	227.6	72.1	0.0	0.00
June	14.7	58.5	11.2	7.0	248.9	78.9	0.0	0.00
July	15.4	59.7	10.4	6.5	216.0	68.5	0.0	0.00
August	12.4	54.3	9.7	6.0	156.4	49.6	0.0	0.00
September	6.4	43.5	9.7	6.0	92.0	29.2	0.0	0.00
October	-3.2	26.2	8.6	5.3	39.7	12.6	4.0	0.13
November	-15.6	3.9	6.1	3.8	13.6	4.3	18.1	0.59
December	-22.1	-7.8	5.0	3.1	2.9	0.9	32.3	1.06

### 3.4 Boundary Conditions

At the ground surface, the net heat energy flux into or out of the ground was calculated at each ground surface node of the finite element model at each time step using a surface energy balance model based on Hwang, 1976.

Ground surface properties for undisturbed terrain, the cleared ROW terrain, and the gravel pad surface are shown in Table 3. Ground surface disturbance for the cleared terrain was simulated by varying the summer albedo and evapotranspiration factors. These values have been shown to reproduce the long-term thaw depths observed at the Fairbanks Surface Disturbance Test site (Linell 1973 and Douglas et. al. 2008), however those results are beyond the scope of this document.

The side boundaries and bottom boundaries were zero-flux boundaries. As such, the geothermal model calculated the temperatures at these boundaries. The side boundaries are far enough away from the thermal disturbance of the ROW that there is no horizontal heat transfer at the sides of the modeling domain. A small non-zero geothermal heat flux could have been included at the bottom boundary, however it was not because it does not significantly affect the calculated temperatures at the relatively small scale depths here, which are on the order of tens of feet. In addition, the geothermal heat flux is very small relative to the net heat flux from energy exchange at the ground surface. Including the geothermal flux would therefore add unnecessary complexity to the model.

To simulate revegetation on the ROW, ground surface properties of summer albedo and evapotranspiration factor were linearly varied over a specified time period from their values during construction to their long-term values. For example, the cleared terrain on the spoil side of the ROW outside of the 53ft permanent ROW was simulated to revegetate from cleared terrain (during construction) to undisturbed terrain over an elapsed time period from 1 to 20 years. Similarly, the gravel pad outside of the 53ft permanent ROW was simulated to revegetate to undisturbed terrain over the same time period, 1 to 20 years. The gravel pad within the permanent 53ft ROW was simulated to revegetate to cleared terrain over a time period from 1 to 5 years. The cleared terrain on the spoil side of the ROW and above the pipe trench was simulated to remain unchanged as cleared terrain throughout the entire simulation period of 30 years.

**Table 3 Ground Surface Properties**

<b>Terrain</b>	<b>Summer Albedo</b>	<b>Winter Albedo</b>	<b>Evapotransp Factor</b>
Undisturbed (trees)	0.65	0.85	0.65
Cleared	0.08	0.85	0.30
Gravel Pad	0.07	0.85	0.20

Pipe temperature boundary conditions were obtained from hydraulics modeling (Baker, 2015) from ASAP pipeline milepost 440 near Fairbanks. The maximum, minimum and average pipe temperatures at MP440, used in the modeling reported herein, were 22.7°F, 42.4 °F and 32.4°F, respectively. From previous thaw depth analyses for pipe integrity, it was observed that the pipe temperatures from this set of hydraulics runs may be warm by 2°F to 3°F, which may have been the result of some conservatism in the hydraulics analysis regarding maximum gas throughput. In any event, the pipe temperatures may be slightly conservative for the thaw depth analysis presented herein but are inconsequential to maximum thaw depths on the ROW which are too far from the pipe to be influenced by it.

### 3.5 Model Calibration

The geothermal model was calibrated such that it would reproduce a MAGT of 31.1°F (-0.5°C) in undisturbed terrain. This is representative of warm permafrost in the Fairbanks area.

A series of one-dimensional (1D) model runs using an undisturbed soil profile was performed. For each run, a constant (time-invariant) snow thermal conductivity was used and the model was run to periodic steady-state (approximately 10 years). This technique was used to find the snow thermal conductivity value such that the model would produce the target MAGT, in this case 31.1°F for Fairbanks.

## 4 ROW THAW DEPTH RESULTS

If present, the top layer of organic peat soils provides an insulative layer in permafrost environments. To assess the insulative effect of preserving the organic soil layer beneath the gravel pad, a pair of two-dimensional (2D) geothermal modeling runs were performed with and without a buried organic layer below the gravel pad.

Figure 6 shows the 30-year thaw depth profile across the ROW for the case with a buried organic layer beneath the gravel pad. The edge of the gravel pad is located 24m (80ft) from the pipe centerline. As shown in the figure, the 30-year thaw depth rises towards the edge of the gravel pad and tapers to the active layer depth of the undisturbed terrain at about 32m (105ft) from the pipe centerline, or about 8m (26ft) from the edge of the gravel pad.

Figure 7 shows the 30-year thaw depth profile across the ROW for the case where the organic layer is not present beneath the gravel pad. In this case the 30-year thaw depth beneath the gravel pad is somewhat deeper, and the influence of the gravel pad thaw extents to about 34m (112ft) from the pipe centerline, or about 10m (33ft) beyond the edge of the gravel pad, which is about 2m (7ft) farther than in the case where the organic layer below the gravel pad was present.

Comparison of Figure 6 and Figure 7 shows that the 30-year thaw depths on the spoil side of the ROW are the same in both cases and as one might expect, the presence of the organic layer below the gravel pad does not affect thaw depth on the spoil side of the ROW.

Figure 8 shows the variation with time of the deepest thaw depth on each side of the ROW. As stated earlier, the cleared terrain on the spoil side of the ROW outside of the permanent 53ft cleared ROW was simulated to revegetate to undisturbed terrain over years 1 to 20. The gravel pad within the 53ft cleared ROW on the gravel pad side of the ROW was simulated to revegetate to a cleared terrain state over years 1 to 5. Outside the 53ft cleared ROW, the gravel pad was simulated to revegetate to undisturbed terrain (treed) over years 1 to 20. As shown in Figure 8 the maximum 30-year thaw depths on the spoil and gravel pad side of the ROW were calculated to be nominally 18ft and 22ft, respectively.

Figure 9 shows the same thaw depth information as Figure 8 for the case where no organic layer was present beneath the gravel pad. In this case, the 30-year thaw depth is unchanged at 18ft as mentioned earlier. Beneath the gravel pad, the 30-year maximum thaw depth increased to nominally 25ft, an increase of about 3ft from the case where an organic layer was present beneath the gravel pad.

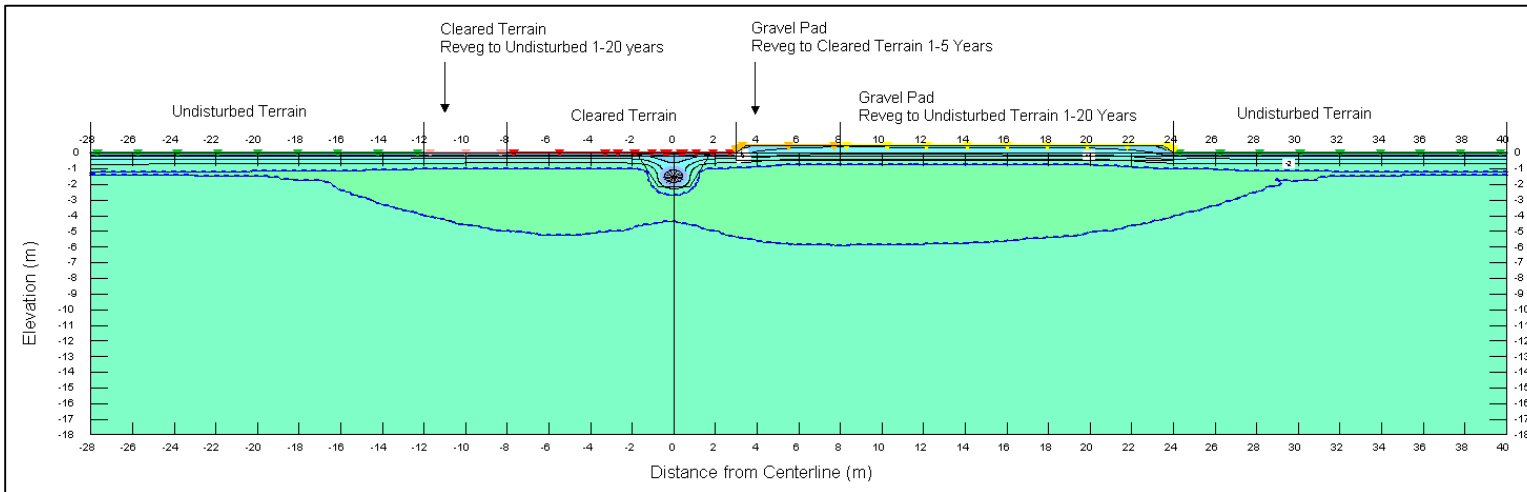

**Figure 6** ROW 30-Year Thaw Depth Profile for Case with Buried Organic Layer below Gravel Pad

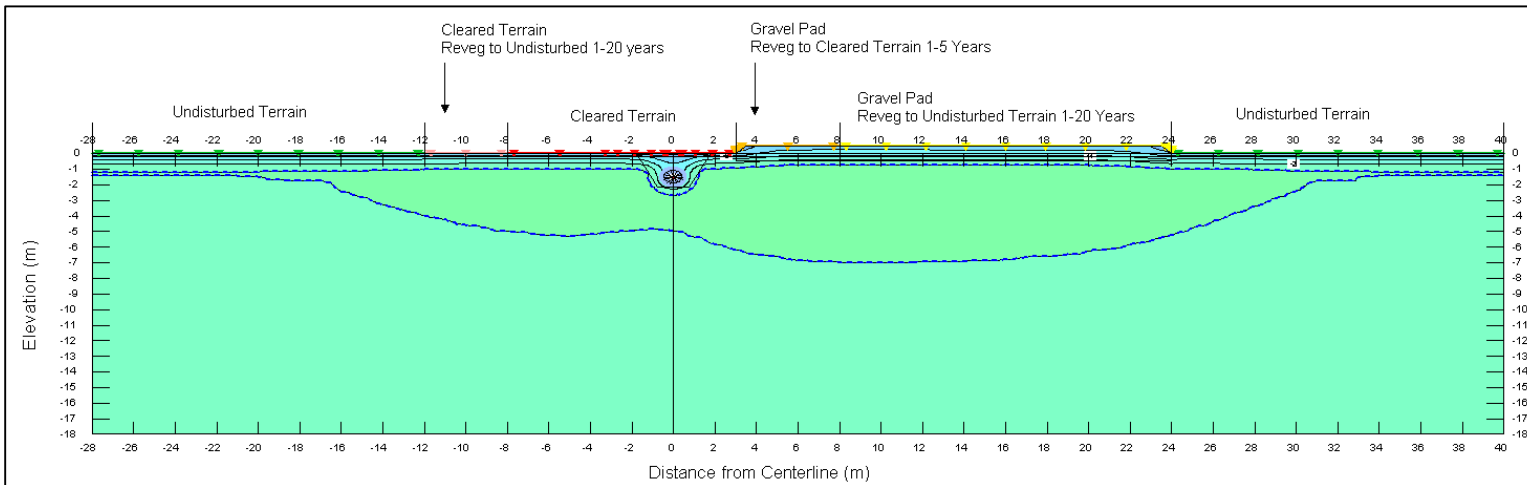

**Figure 7** ROW 30-Year Thaw Depth Profile for Case without Buried Organic Layer below Gravel Pad

### ASAP Right-of-Way Long-Term Thaw Depths Buried Organic Soil below Gravel Pad

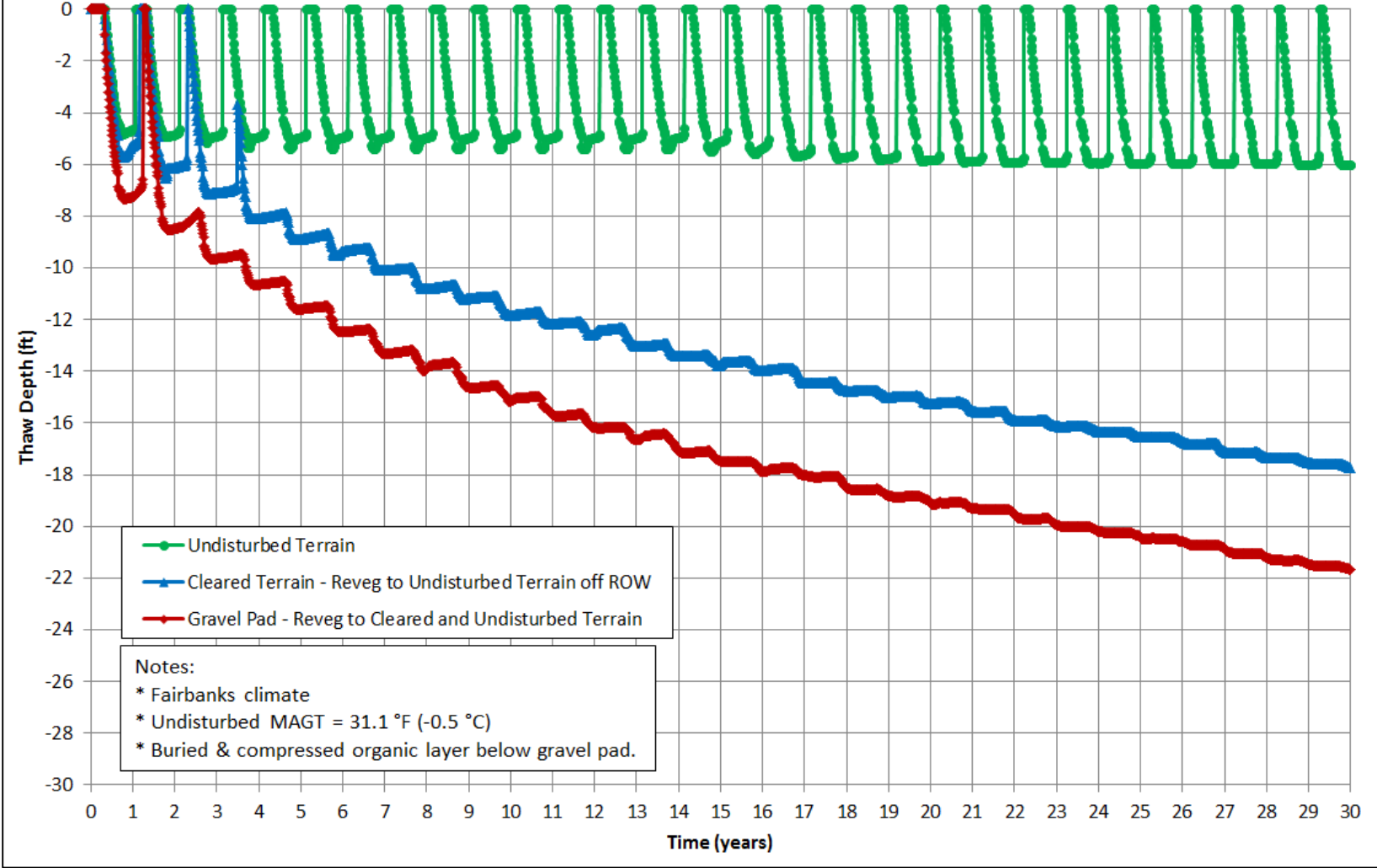

Figure 8 ROW Thaw Depths for Case with Buried Organic Layer below Gravel Pad

## ASAP Right-of-Way Long-Term Thaw Depths No Organic Soil below Gravel Pad

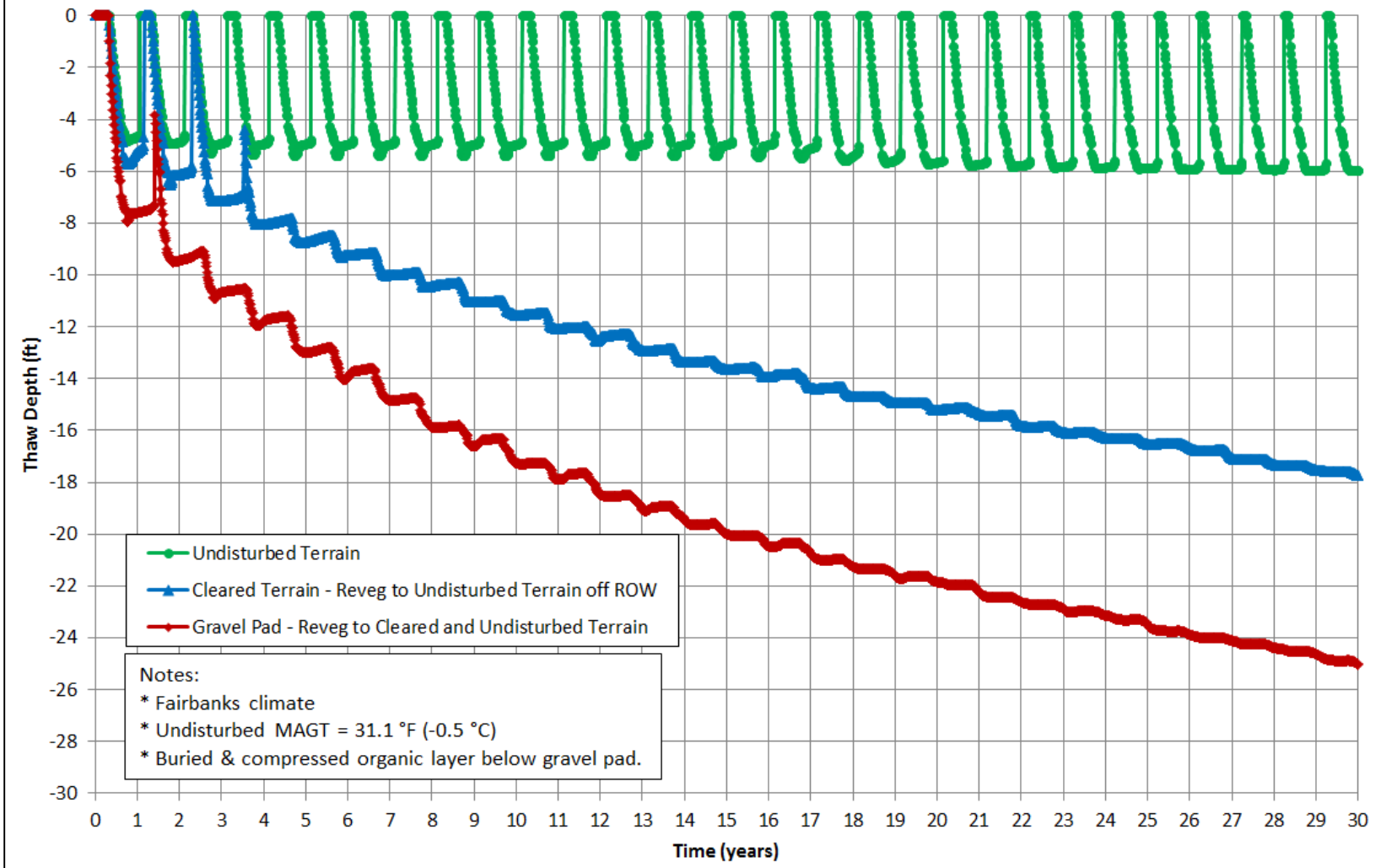

Figure 9 ROW Thaw Depths for Case without Organic Layer below Gravel Pad

## 5 CONCLUSIONS

The following conclusions were drawn from the thaw depth modeling results presented herein:

- Disturbances to the ground surface during construction and subsequent pipeline operations cause changes to the surface heat energy balance and a corresponding increase to net heat energy flux into the ground at the ground surface. The increase in net energy flux into the ground causes long-term progressive thaw depth deepening that does not freeze back over the winter seasons.
- It is reasonable to expect deeper thaw depth beneath the 18in thick gravel pad compared to the thaw depth beneath cleared terrain. This is a result of higher net energy influx from the gravel pad caused by higher solar radiation absorption and less evapotranspiration of the gravel pad surface compared to the vegetated surface of cleared terrain. For cleared terrain, the 30-year thaw depth was calculated to be 18ft whereas beneath the gravel pad the 30-year thaw depth was calculated to be 22ft to 25ft with and without an organic layer below the gravel pad, respectively.
- The thermal influence of the gravel pad extends beyond the edge of gravel pad by about 26ft and 33ft in the cases with and without an organic layer below the gravel pad, respectively.

## 6 CLOSURE

We trust that this technical memo suits your present requirements. If you have any questions or comments, please call the undersigned at 403-727-0260.

Yours truly,

**MATRIX SOLUTIONS INC.**

Ron Coutts, M.Sc., P.Eng. (AB) Senior Geological Engineer

### DISCLAIMER

We certify that this letter report is accurate and complete and accords with the information available at the time the work was undertaken. Information provided by third parties is believed to be accurate but is not guaranteed. We have exercised reasonable skill, care and diligence in assessing the information obtained during the preparation of this letter report.

This letter report was prepared for Michael Baker Jr. Inc. and the Alaska Gas Development Corp. The letter report may not be relied upon by any other person or entity without our written consent and that of Michael Baker Jr. Inc. and Alaska Gas Development Corp. Any uses of this letter report by a third party, or any reliance on decisions made based on it, are the responsibility of that party. We are not responsible for damages or injuries incurred by any third party, as a result of decisions made or actions taken based on this letter report.

## 7 REFERENCES

Baker, 2015. "PL Pressure Temperature Data 010816.xlsx". Hydraulics data via email, Michael Baker Jr. Inc., January 8, 2016.

Douglas, T. A., Jorgenson, M. T., Kanevskiy, M., Romanovsky, V. E., Shur, Y., Yoshikawa, K., 2008. "Permafrost Dynamics at the Fairbanks Permafrost Experimental Station Near Fairbanks, Alaska", Ninth International Conference on Permafrost, pp. 373--378.

Geo-Slope, 2016. GeoStudio TEMP/W product webpage:  
<http://www.geo-slope.com/products/tempw.aspx>

Hwang, C.T., 1976. "Predictions and observations on the behaviour of a warm gas pipeline on permafrost". Can. Geotech. J., vol. 13, pp. 452-480.

Linell, K. A., 1973. "Long-term Effects of Vegetative Cover on Permafrost Stability in an Area of Discontinuous Permafrost", *Second International Conference on Permafrost*, pp. 688 to 693.

- Page Intentionally Left Blank -